



# NHBC Standards 2017

---

Effective from 1 January 2017



Raising Standards. Protecting Homeowners



## Welcome to the NHBC Standards 2017

This edition will be effective for every new home registered with NHBC where foundations are begun on or after the 1st January 2017.

2016 saw the introduction of a brand new format for the NHBC Standards, making them easier to use and more accessible than ever before. Feedback from our own staff and builders has been very encouraging and we are delighted that the NHBC Standards continues to be the 'go to' document for technical guidance for the house-building industry.

Building on this success, Standards 2017 includes a number of technical updates and revisions, including the new Chapter 6.11 'Render'. This traditional building method is used in the house-building industry to provide a modern and clean look to new homes, but it is important that render is correctly detailed to remain durable and aesthetically pleasing. Chapter 6.11 contains clear guidance on how to achieve this and avoid issues such as cracking and crazing, which can be a source of real homeowner dissatisfaction.

To keep pace with changes in the house-building industry, the content of the NHBC Standards is reviewed on an on-going basis and new content is developed with assistance and in consultation with the industry.

As ever, the issue of construction quality is paramount in all of NHBC's work, as such this edition of the NHBC Standards also contains new or updated technical guidance on these key issues:

- Ventilation terminals
- Preparation of garden areas
- Pitched roofs
- Waterproofing
- Timber in balconies

I do hope that you will quickly become familiar with the NHBC Standards 2017 edition and find it of significant benefit in the design and construction of high quality, new homes across the UK.



**Mike Quinton**

NHBC Chief Executive

# Contents

## Welcome – Part 1

- Contents
- Contact us
- What's changed

## Introduction – Part 2

- 2.1 The Standards and Technical Requirements

## General – Part 3

- 3.1 Concrete and its reinforcement
- 3.2 Cold weather working
- 3.3 Timber preservation (natural solid timber)

## Foundations – Part 4

- 4.1 Land quality – managing ground conditions
- 4.2 Building near trees
- 4.3 Strip and trench fill foundations
- 4.4 Raft, pile, pier and beam foundations
- 4.5 Vibratory ground improvement techniques

## Substructure, ground floors, drainage and basements – Part 5

- 5.1 Substructure and ground bearing floors
- 5.2 Suspended ground floors
- 5.3 Drainage below ground
- 5.4 Waterproofing of basements and other below ground structures

## Superstructure (excluding roofs) – Part 6

- 6.1 External masonry walls
- 6.2 External timber framed walls
- 6.3 Internal walls
- 6.4 Timber and concrete upper floors
- 6.5 Steelwork
- 6.6 Staircases
- 6.7 Doors, windows and glazing
- 6.8 Fireplaces, chimneys and flues
- 6.9 Curtain walling and cladding
- 6.10 Light steel framed walls and floors
- 6.11 Render <sup>new</sup>

## Roofs – Part 7

- 7.1 Flat roofs and balconies
- 7.2 Pitched roofs

## Services – Part 8

- 8.1 Internal services
- 8.2 Low or zero carbon technologies
- 8.3 Mechanical ventilation with heat recovery

## Finishes – Part 9

- 9.1 A consistent approach to finishes
- 9.2 Wall and ceiling finishes
- 9.3 Floor finishes
- 9.4 Finishes and fitments
- 9.5 Painting and decorating

## External works – Part 10





- 10.1 Garages
- 10.2 Drives, paths and landscaping

## How we can help you

Useful contact information is shown below, should you need to contact us for:

- more copies of the printed book
- advice and guidance from our technical helpline
- support for Standards Plus.

### Contact information

<p><b>More copies</b></p> 	<p>For more copies of NHBC Standards,  <b>Call: 0344 633 1000</b> and ask for 'Shop'  <b>Email: <a href="mailto:shop@nhbc.co.uk">shop@nhbc.co.uk</a></b>, or  <b>Visit: <a href="http://www.nhbc.co.uk/Builders/Shop/TechnicalStandards">www.nhbc.co.uk/Builders/Shop/TechnicalStandards</a></b></p>
<p><b>Technical helpline</b></p> 	<p>For technical help and advice,  <b>Call: 0344 633 1000</b> and ask for 'Technical', or  <b>Email: <a href="mailto:technical@nhbc.co.uk">technical@nhbc.co.uk</a></b></p>
<p><b>Standards Plus</b></p> 	<p>The online version of the NHBC Standards 2017 – Standards Plus – is freely available to all visitors to the NHBC website. Complete with supplementary technical content and further guidance notes, supporting links to external sites and 3D animations, Standards Plus expands and optimises the NHBC Standards 2017 for use on desktop and mobile devices.  <b>Visit: <a href="http://www.nhbc.co.uk/Standardsplus2017">www.nhbc.co.uk/Standardsplus2017</a></b>  For any questions or comments regarding Standards Plus,  <b>Email: <a href="mailto:standardsplus@nhbc.co.uk">standardsplus@nhbc.co.uk</a></b></p>
<p><b>Contact us</b></p> 	<p>If there is anything else you would like to talk to us about.  <b>Call: 0344 633 1000</b>  <b>Visit our contact us tool: <a href="http://www.nhbc.co.uk/contact-us">www.nhbc.co.uk/contact us</a>, or</b>  <b>Write to:</b>  <b>Milton Keynes Office</b>  NHBC, NHBC House, Davy Avenue, Knowlhill, Milton Keynes, Bucks MK5 8FP  <b>Edinburgh Office</b>  NHBC Scotland, Suite 4, 5 New Mart Place, Edinburgh EH14 1RW  <b>Belfast Office</b>  NHBC, Northern Ireland and Isle of Man, Holyrood Court, 59 Malone Road, Belfast BT9 6SA</p>

## What's changed?

### Major technical changes

The following major technical changes have been made to Standards 2017:

- Chapter 6.11 'Render' introduced.

### Minor technical changes

The following minor technical changes have been made to Standards 2017:

- Chapter 3.3 Table 1 has been updated.
- Guidance for foundation types has been reinstated in Clause 4.5.6.
- In response to feedback, a number of editorial changes have been made to Chapter 5.4.
- Guidance for stone veneer cladding systems has been introduced to Clause 6.1.16.
- A number of minor changes have been made to Chapter 7.2. 'Pitched roofs', including new guidance for fixing lateral restraint straps.
- Guidance for gas supply to cooker spaces in Clause 8.1.8 has been revised.
- Additional guidance for ventilation terminals has been introduced in Clause 8.1.12.
- Guidance for the preparation of garden areas has been revised in Clauses 10.2.8 and 10.2.9.

### 3D models

3D models can be accessed directly within Standards Plus, the online version of the Standards, by clicking on the embedded icons. They can also be viewed on the NHBC 3D Viewer app, which hosts a library of the 3D models to view on iOS and Android devices.

Using your smartphone and QR reader, scan the codes below to go directly to Standards Plus 2017, or the NHBC 3D Viewer app (via the App Store and Google Play service).

#### Scan Me...

Got a smartphone and QR reader app? Scan the codes below to go directly to Standards Plus 2017, or learn more about the NHBC 3D Viewer app, via your phone's web browser.

Standards Plus 2017

NHBC 3D Viewer app



# The Standards and Technical Requirements

## CHAPTER 2.1

This chapter introduces the NHBC Standards and contains the Technical Requirements.



Raising Standards. Protecting Homeowners

### Application of the Standards

The NHBC Standards contain the Technical Requirements, performance standards and guidance for the design and construction of homes acceptable to NHBC. The home is defined in NHBC Rules for builders and developers registered with NHBC. The Standards come into effect for every NHBC registered home whose foundations are begun on or after 1 January 2017, and they apply throughout the UK, unless otherwise stated.

### Composition of the Standards

The Standards are divided into 10 Parts, each covering a particular element and subdivided into chapters which, in principle, follow the normal build sequence (the list of chapters is shown in the Contents section of Part 1). The front cover of each chapter contains its scope, together with a list of its contents.

### Technical Requirements

The Technical Requirements are shown in **red text** in this chapter, and **must** be met by the builder.

### Performance standards

The performance standards support the Technical Requirements and are shown in bold black text backed with a shaded box. Where the performance standards are followed, the Technical Requirements for that particular item of work will be met. Alternative standards of performance will be acceptable **only** if, in the opinion of NHBC, the Technical Requirements for that particular item of work are met and the standard achieved is not lower than the stated performance standard.

### Guidance

Guidance on how the performance standard may be met is shown in black text and is based on normal construction procedures and recommended practices which have been shown to be satisfactory and acceptable over time. NHBC will consider alternative methods to meet specific requirements, subject to prior consultation and evaluation.

Guidance is also contained in illustrations and digital 3D models.

Guidance is provided to demonstrate specific technical principles, and should not be used as working construction details.

### Limitations on use

The Technical Requirements, performance standards and guidance form acceptable technical benchmarks for a particular item of work, but do not form a complete specification and should not be used as such in contracts. Individual chapters cover, as far as practical, the requirements for particular elements of construction. To avoid repetition, some cross-referencing is made between chapters.

The NHBC Standards do not apply to:

- health and safety matters relating to building operations
- planning matters except where specifically referred to in these Standards.

Such matters are covered by statutory requirements.

### Interpretation

Where a difference exists in how to interpret the Technical Requirements, performance standards and guidance, this would generally be resolved by further consultation, failing which, NHBC will exercise its right to decide in accordance with the NHBC Rules.

### Testing

Where required, samples of materials, products and systems shall be tested in accordance with Technical Requirement R3 and the NHBC Rules.

## Standards and codes of practice

Where NHBC Standards refer to authoritative documents such as British Standards, the documents shall be the editions current at the time of Building Regulation approval, unless other recommendations are agreed by NHBC in writing.

The standards referred to in the NHBC Standards comprise specifications, codes of practice and published documents that are published by BSI, the European Committee for Standardization (CEN) and the International Organization for Standardization (ISO).

## Tolerances

All work shall be within acceptable tolerances. Where applicable, account should be taken of Chapter 9.1 'A consistent approach to finishes'. In other situations, tolerances will be those currently acceptable in the house-building industry.

## Acknowledgements

NHBC is indebted to members of the Standards Committee, the Standards Review Group, the Scottish Technical Subcommittee and the Northern Ireland Technical Subcommittee for their work in developing and maintaining the NHBC Standards.

NHBC also wishes to acknowledge the help given by consultants, authoritative organisations, individuals and staff.

## Technical Requirements

**The Builder shall ensure that the work complies with the Technical Requirements.**

### R1 Statutory requirements

**Work shall comply with all relevant Building Regulations and other statutory requirements relating to the completed construction work.**

NHBC will generally accept work that accords with relevant Building Regulations/Building Standards and supporting documents. Exceptions would be where NHBC has a higher standard.

### R2 Design requirement

**Design and specification shall provide satisfactory performance.**

Account shall be taken of:

a) The land quality, including:

- i) climate
- ii) topography
- iii) geology and ground conditions
- iv) contamination
- v) workings below ground
- vi) previous use of the site
- vii) any other aspect, on or adjacent to the site, which could affect the design.

Where appropriate, the land quality will have to be determined by a person acceptable to NHBC.

b) The structural adequacy of the works. The design, with appropriate factors of safety, shall satisfactorily allow for loads during and after construction and for their transfer to the supporting structure, or foundation, without undue movement, including:

- i) self weight
- ii) all imposed loads, including wind loads
- iii) construction loads.

c) The geographical location of the site, including:

- i) exposure to wind and rain
- ii) topography.

d) The position of the dwelling on the site, especially with reference to the dwelling's exposure to the weather, including at early stages in the development of a site, even if it is eventually protected by structures built later.

e) The position of building elements within the construction works, including the interrelationship of materials and constructions.

f) The security of the dwellings.



### R3 Materials requirement

#### All materials, products and building systems shall be suitable for their intended purpose.

The structure of the home shall, unless specifically agreed otherwise in writing with NHBC, have a life of at least 60 years. Individual components and assemblies, not integral to the structure, may have a lesser durability and need planned maintenance, repair or replacement during that period.

Account shall be taken of the use and location of materials, products and building systems in relation to:

- durability of both the structure and individual components and assemblies
- geographical location
- position on the site
- position within the structure.

Materials, products and building systems will normally be acceptable if they comply with the following:

#### a) MATERIALS AND PRODUCTS USED FOR CRITICAL FUNCTIONS

Functions critical to performance are: structure, fire resistance, weatherproofing, durability, thermal and sound insulation, services including heating appliances and flues. Any of the following are acceptable:

- i) performance in accordance with standards set by NHBC, or
  - ii) where no NHBC standard is set, compliance with the relevant British Standard or equivalent European Technical Specification approved by a Committee for Standardisation, provided they are used in accordance with the relevant Code of Practice, or
  - iii) compliance with standards not lower than those defined in a relevant British Standard specification or equivalent, provided their use is accepted by NHBC, or
  - iv) satisfactory assessment by an appropriate independent technical approvals authority accepted by NHBC, or
  - v) use of materials and products in accordance with well established satisfactory custom and practice, provided that such custom and practice is acceptable to NHBC, or
  - vi) acceptance, in writing, by NHBC that the quality and use is satisfactory.
- #### b) MATERIALS AND PRODUCTS USED FOR NON-CRITICAL FUNCTIONS
- Compliance with the above acceptance criteria for critical functions or strictly in accordance with manufacturers' recommendations for the specific use.
- #### c) RECLAIMED MATERIALS
- Reclaimed materials may only be reused with the prior agreement of NHBC. Independent certification of suitability may be required.
- #### d) PROPRIETARY BUILDING SYSTEMS
- Reference should be made to R3a iv.
- #### e) TIMBER DURABILITY
- Reference should be made to Chapter 3.3 'Timber preservation (natural solid timber)'.
- #### f) RECOVERED AGGREGATES

Aggregates derived from recovered inert waste, e.g. recycled aggregate, should only be used where it can be demonstrated that the inert waste material has been fully recovered, has ceased to be a waste as defined by the Waste Framework Directive 2008 and has become a product. To this end, recovered aggregates produced by a supplier complying with a recognised defined quality management scheme such as the WRAP Quality Protocol and meeting end-of-waste criteria, will be acceptable to NHBC.

#### Note

Equivalents to British Standards or technical approvals authority shall be those accepted in the UK.

### R4 Workmanship requirement

#### All work shall be carried out in a proper, neat and workmanlike manner.

The Builder shall ensure that:

- a) the conditions of the materials, products and the completed work are satisfactory
- b) appropriate precautions are taken to prevent damage
- c) account is taken of the following:
  - i) the requirements of the design
  - ii) suitable methods of unloading and handling
  - iii) proper protection during storage
  - iv) use of correct installation methods
  - v) protection against weather during construction (including excessive heat, cold, wetting or drying)
  - vi) protection against damage by following trades.

## R5 Structural design requirement

**Structural design shall be carried out by suitably qualified persons in accordance with British Standards and Codes of Practice.**

The following shall be designed by Chartered Civil or Structural Engineers whose status (including professional indemnity insurance) is accepted by NHBC:

- a) foundations on hazardous ground where the hazard makes special consideration necessary. (Note: This would not apply to matters for which NHBC sets standards, such as building near trees, except where specified to the contrary)
- b) foundations and superstructure of every building over three storeys in height
- c) certain types of foundations and retaining walls, as required in the individual chapters of the NHBC Standards
- d) any structural element which is not based on specific design criteria as laid down in the chapters of the NHBC Standards
- e) any dwelling not constructed in accordance with UK traditional practice.

### Note

Other structural elements may be designed by a Chartered Civil or Structural Engineer or others whose status (including professional indemnity insurance) is accepted by NHBC.

The structural design shall take account of the durability requirement in Technical Requirement R3 Materials.

In England, Wales, Northern Ireland and the Isle of Man, structural design may be undertaken by the Builder's own Engineer or a Consulting Engineer employed by the Builder. Where specialist subcontractors undertake the design, it must be separately appraised by the Builder's own Engineer or by a Consulting Engineer employed by the Builder to ensure that the site investigation, choice of foundations, siting and construction of dwellings are properly taken into account and that the design is appropriate for the loading and conditions.

In Scotland, the Engineer shall be independent of the Builder and specialist subcontractor.

Account shall be taken of all parts of the following British Standards:

- |  |   |
|--|---|
| ■ Eurocodes and their respective National Annexes.         | ■ BS EN 1993. Eurocode 3: 'Design of steel structures'.   |
| ■ BS EN 1990. Eurocode 0: 'Basis of structural design'.    | ■ BS EN 1995. Eurocode 5: 'Design of timber structures'.  |
| ■ BS EN 1991. Eurocode 1: 'Actions on structures'.         | ■ BS EN 1996. Eurocode 6: 'Design of masonry structures'. |
| ■ BS EN 1992. Eurocode 2: 'Design of concrete structures'. | ■ BS EN 1997. Eurocode 7: 'Geotechnical design'.          |

Alternatively, designs in accordance with BS 8103 'Structural design of low rise buildings' will be acceptable.

The Builder shall:

- |   |  |
|---|--|
| ■ require the Engineer to issue clear instructions for site personnel         | ■ require the Engineer or his representative to carry out such inspections as may be required by NHBC to ensure the adequacy of the design and construction. |
| ■ not permit departure from the design without the Engineer's written consent |  |

The Builder shall ensure that the Engineer visits the site during construction:

- |  |  |
|--|--|
| ■ when the foundations have been designed under this Technical Requirement, or | ■ when specifically required by NHBC in these Standards. |
|--|--|

The Engineer shall satisfy himself that the design is suitable for the conditions encountered on the site of each dwelling.

When requested by NHBC, the Builder shall:

- |   |   |
|---|---|
| ■ produce such design documents, calculations and prescribed forms of certification as NHBC requires for scrutiny | ■ arrange for NHBC staff to have access to places where off-site fabrication is taking place. |
| ■ provide design documents and assembly instructions, solely for the use of NHBC staff                            |   |

# Concrete and its reinforcement

## CHAPTER 3.1

This chapter gives guidance on meeting the Technical Requirements for concrete and its reinforcement.

3.1.1	Compliance	01
3.1.2	Provision of information	01
3.1.3	Storage of materials	01
3.1.4	Site-mixed concrete	01
3.1.5	Ready-mixed concrete	03
3.1.6	Concrete specification	03
3.1.7	Admixtures	06
3.1.8	Special types of concrete	07
3.1.9	Design of reinforced concrete	07
3.1.10	Installation of reinforcement	08
3.1.11	Blinding concrete	09
3.1.12	Formwork	09
3.1.13	Before concreting	09
3.1.14	Casting	09
3.1.15	Curing	10
3.1.16	Testing	10
3.1.17	Glossary	10



Raising Standards. Protecting Homeowners

### Introduction

Concrete design and specification should comply with the relevant British Standards. Mix design should take account of strength and durability, and follow recognised standards and practices. Alternatively, mixes in accordance with the guidance in this chapter will be acceptable. This applies to plain and reinforced concrete, whether precast or in-situ.

### Compliance <sup>3.1.1</sup>

*Also see: Chapter 2.1, BS 8500 and BS EN 206*

**Concrete and its reinforcement shall comply with the Technical Requirements.**

Concrete and its reinforcement that complies with the guidance in this chapter, which covers plain and reinforced concrete, precast or in-situ, will generally be acceptable.

Mix design should take account of strength and durability, and comply with the relevant British Standards.

### Provision of information <sup>3.1.2</sup>

**Designs and specifications shall be produced in a clearly understandable format, include all relevant information and be distributed to appropriate personnel.**

Design and specification information should be issued to site supervisors, relevant specialist subcontractors and suppliers, and include the following information:

<b>Ground aggressivity</b>	<ul style="list-style-type: none"> <li>■ Design sulfate class (DS class).</li> </ul>	<ul style="list-style-type: none"> <li>■ Aggressive chemical environment for concrete class (ACEC Class).</li> </ul>
<b>Strength and durability</b>	<ul style="list-style-type: none"> <li>■ Strength.</li> <li>■ Maximum free water/cement ratio and/or minimum cement content.</li> <li>■ Consistence class (e.g. slump).</li> </ul>	<ul style="list-style-type: none"> <li>■ Air content (where required).</li> <li>■ Aggregate size.</li> <li>■ Colour.</li> </ul>
<b>Mix design and additional protective measures (APM)</b>	<ul style="list-style-type: none"> <li>■ Specification of mix designs (concrete strength class).</li> </ul>	<ul style="list-style-type: none"> <li>■ Details of any Additional Protective Measures.</li> </ul>
<b>Reinforcement and movement joints</b>	<ul style="list-style-type: none"> <li>■ Cover to reinforcement.</li> <li>■ Reinforcement, plans, sections and bending schedules.</li> <li>■ Reinforcement details at supporting edges.</li> <li>■ Camber in beams and slabs, where appropriate.</li> </ul>	<ul style="list-style-type: none"> <li>■ Reinforcement around openings.</li> <li>■ Drawings and bending schedules should be prepared in accordance with BS 8666.</li> <li>■ Movement joints.</li> </ul>
<b>Formwork</b>	<ul style="list-style-type: none"> <li>■ Formwork materials and features.</li> <li>■ Joints.</li> </ul>	<ul style="list-style-type: none"> <li>■ Mould release agents.</li> <li>■ Holes for services.</li> </ul>
<b>Finishing treatments</b>	<ul style="list-style-type: none"> <li>■ Concrete to be left untouched or with minimum finishing may require detailed formwork drawings indicating the position and detail of joints between shutters, corners and other critical junctions.</li> </ul>	
<b>Testing</b>	<ul style="list-style-type: none"> <li>■ Number and frequency of samples to be taken.</li> <li>■ Test laboratory details.</li> </ul>	<ul style="list-style-type: none"> <li>■ Recording of results.</li> </ul>
<b>Curing and protection</b>	<ul style="list-style-type: none"> <li>■ Requirements for curing and striking formwork.</li> </ul>	<ul style="list-style-type: none"> <li>■ Minimum period for striking/removal of formwork, curing and protection.</li> </ul>

### Storage of materials <sup>3.1.3</sup>

*Also see: Chapter 3.2*

**Materials shall be properly stored to avoid impairing the performance of the finished concrete.**

Where materials need to be stored, the following precautions should be taken:

- Follow manufacturer's recommendations on maximum storage time.
- Store cement in a dry place and keep each type separate.
- Store different sizes of aggregate in separate bays.
- Keep sand and aggregate clean and dry (allowance should be made in the concrete batching for moisture in the sand and aggregate).

### Site-mixed concrete <sup>3.1.4</sup>

**Site-mixed concrete shall be designed and mixed to ensure sufficient strength and durability.**

Concrete should be mixed using an appropriate method to achieve the required strength and durability. Except for very small quantities, a mechanical mixer should be used. Where hand mixing, add an extra 10% of cement to the quantities shown in Tables 2 and 3.

**Table 1:** Guidance for site mixed-concrete

Material	Guidance
Cement or cementitious material	<ul style="list-style-type: none"> <li>BS 8500-2 including Annex A.</li> </ul>
Air-entraining admixtures	<ul style="list-style-type: none"> <li>Should not be used in standardised prescribed concrete mixes.</li> </ul>
Admixtures, other than air-entraining admixtures	<ul style="list-style-type: none"> <li>BS EN 934-2.</li> </ul>
Water	<ul style="list-style-type: none"> <li>Mains supply water, or in accordance with BS EN 1008.</li> </ul>
Aggregates	<ul style="list-style-type: none"> <li>Compliant with BS EN 12620 'Aggregates for concrete'.</li> <li>Mixed, and precautions taken, as described in BRE Digest 357.</li> <li>Fine and/or of coarse proportions mixed as specified.</li> <li>Proportioned to ensure a reasonable consistency, when supplied as a mixture.</li> <li>Checked and precautions taken when shrinkable aggregates, aggregates susceptible to alkali attack or excessive moisture movement, or unfamiliar materials are used.</li> <li>Within the limits of the aggregate carbon range (ACR), when subject to aggressive sulfate ground conditions.</li> <li>Assessed in accordance with Technical Requirement R3 where materials are recovered or proprietary.</li> </ul>

The information below applies to cement strength class 32.5 and 20mm maximum aggregate size. Where cement strength class 42.5 or higher is used, the cement weight should be decreased by 10%.

**Table 2:** Mix proportions by weight

Standardised prescribed mix	Consistence class (slump in mm)	Cement (kg)	Fine aggregate (kg)	Coarse aggregate (kg)
ST1	S1 (10-40)	230	770	1155
ST2	S2 (50-90)	265	760	1135
ST2	S3 (100-150)	285	735	1105
ST2	S4 (160-210)	300	815	990
ST3	S2 (50-90)	295	745	1120
ST4	S2 (50-90)	330	735*	1100
ST5	S2 (50-90)	375	720*	1080

\* Fine aggregate grading to be grades CP or MP only of BS EN 12620.

**Table 3:** Mix proportions by volume using a maximum 20mm aggregate size

Cement strength class	Standardised prescribed mix	Consistence class (slump in mm)	Number of (25 kg) bags of cement	Fine aggregate (litres)	Coarse aggregate (litres)
32.5	ST1	S1 (10-40)	1	60	85
	ST2	S2 (50-90)	1	50	75
	ST2	S3 (100-150)	1	45	70
	ST2	S4 (160-210)	1	50	60
	ST3	S2 (50-90)	1	45	65
42.5 or higher	ST1	S1 (10-40)	1	65	95
	ST2	S2 (50-90)	1	55	80
	ST2	S3 (100-150)	1	50	75
	ST2	S4 (160-210)	1	55	65
	ST3	S2 (50-90)	1	50	75

### Ready-mixed concrete <sup>3.1.5</sup>

**Ready-mixed concrete shall be from a supplier operating under a quality control system acceptable to NHBC and be of sufficient strength and durability.**

Ready-mixed concrete is acceptable from suppliers who operate under a full quality control scheme such as:

- the Quality Scheme for Ready-Mixed Concrete (QSRMC), or
- the BSI Kitemark scheme.

Other suppliers may be suitable if they operate to an equivalent quality standard acceptable to NHBC.

Ready-mixed concrete should be ordered to a detailed specification conforming to BS 8500 and BS EN 206-1.

When designated mixes are used, the ready-mix supplier will only require the mix designation, and consistence class.

Ready-mixed concrete should be:

- GEN mix
- FND mix, or
- RC mix.

Delivery information should be checked to ensure that the concrete meets the requirements given in the design.

### Concrete specification <sup>3.1.6</sup>

*Also see: BRE Digest 357, BRE Special Digest 1, BS 8500, BS 8500-1 and BS EN 206-1*

**Concrete shall be specified correctly to ensure adequate strength and durability. Issues to be taken into account include:**

- |  |                                      |
|--|--------------------------------------|
| a) concrete in non-hazardous conditions            | e) effects of chlorides              |
| b) exposure to climatic and atmospheric conditions | f) effects of alkali-silica reaction |
| c) exposure to aggressive ground conditions        | g) aggregates.                       |
| d) exposure to sulfates and acids in groundwater   |                                      |

Concrete mixes should be suitable for particular end uses and specified in accordance with BS 8500-1 as either:

- designated mix, which is supplied ready mixed, or
- standardised prescribed mix for site mixing.

Designated mixes should conform to Table 5 of BS 8500-2:2012. Standardised prescribed mixes should conform to Tables 2 and 3 in this chapter.

Mixes should also be designed for the expected conditions of the geographical location of the site and the location of the concrete element in the structure. Higher grade concrete has greater resistance to chemical and mechanical damage and should be specified accordingly.

In addition to the issues in this section, durability is reliant on:

- correct control of the water:cement ratio
- full compaction of the placed concrete
- good curing.

### Concrete in non-hazardous conditions

**Table 4:** Minimum specifications for general purpose concrete mixes

Location and use	BS 8500 and BS EN 206-1		
	Ready-mixed concrete (designated mix)	Site-mixed concrete (standardised prescribed mix)	Consistence class
<b>Substructure and ground floors</b> <ul style="list-style-type: none"> <li>■ Rough blinding (non-structural).</li> <li>■ Infill.</li> <li>■ Unreinforced oversite concrete below timber floors.</li> </ul>	GEN1	ST2	S3
<ul style="list-style-type: none"> <li>■ Structural blinding and over break.</li> <li>■ Strip foundations.</li> <li>■ Trench fill.</li> <li>■ Other mass concrete foundations.</li> <li>■ Fill to wall cavity.</li> <li>■ Solid filling under steps.</li> </ul>	GEN1	ST2	S3/S41 <sup>(1)</sup>
<ul style="list-style-type: none"> <li>■ House floors not designed as suspended and not reinforced:               <ul style="list-style-type: none"> <li>– Permanent finish to be added, e.g. screed or floating floor.</li> <li>– No permanent finish to be added, e.g. carpet.</li> </ul> </li> </ul>	GEN1 GEN2	ST2 ST3	S2 S2

**Table 4 (continued):** Minimum specifications for general purpose concrete mixes

Location and use	BS 8500 and BS EN 206-1		
	Ready-mixed concrete (designated mix)	Site-mixed concrete (standardised prescribed mix)	Consistence class
■ Garage floors not designed as suspended and not reinforced.	GEN3	ST4	S2
■ House and garage ground floor slabs: – Fully or nominally reinforced, either ground bearing, suspended or over sub-floor voids.	RC35	ST5 <sup>(2)</sup>	S2
<b>Superstructure</b>			
■ General reinforced concrete exposure class <sup>(3)</sup> to BS8500-1: – Nominal cover to reinforcement of 35mm (which is the minimum cover of 25mm plus an allowance in design for deviation of 10mm). – XC1 (dry) and XC2 (wet, rarely dry). – XC3 (moderate humidity), XC4 (cyclic wet and dry) and XF1 (freeze/thaw attack and no de-icing agent). – Nominal cover to reinforcement of 40mm (which is the minimum cover of 30mm plus an allowance in design for deviation of 10mm). – Any exposure class (XC1-4 and XF1).	RC30 RC40  RC35	<sup>(4)</sup> –  <sup>(5)</sup>	S2 S2  S2
<b>In-situ external concrete</b>			
■ Drives and paths.	PAV1	ST5 <sup>(6)</sup>	S2
■ Foundations for precast concrete paving slabs.	GEN1	ST1	S1

**Notes**

- Consistence class S3 should be used for strip foundation concrete and consistence class S4 should be used for trench fill foundation concrete.
- ST4 mix for house and garage floors may only be used in conjunction with Chapter 5.2 'Suspended ground floors'. In all other cases, the designated mix should be used.
- Exposure classes (XC1-4 and XF1) are defined in BS 8500-1 Table A.1.
- In this situation, ST4 mix may be used only for small quantities of concrete. In all other cases, the appropriate designated mix should be used.
- In this situation, an ST5 mix may be used only for small quantities of concrete. In all other cases, the appropriate designated mix should be used.
- Not suitable in areas of severe exposure to frost attack. This is equivalent to exposure class XC4 above.

**Exposure to climatic and atmospheric conditions**

Any concrete mix should be designed for the conditions expected at the geographical location of the site and at the location of the element in the structure.

**Table 5:** Exposure classes and examples of where they may occur, based on Table 1 of BS EN 206-1

Exposure class	Environment	Exposure conditions
XC1	Dry or permanently wet	Concrete inside buildings with low air humidity. Concrete permanently submerged in water.
XC2	Wet, rarely dry	Concrete surfaces subject to long-term water contact. Many foundations.
XC3	Moderate humidity	Concrete inside buildings with moderate or high air humidity. External concrete sheltered from rain.
XC4	Cyclic wet and dry	Concrete surfaces subject to water contact, not within exposure class XC2.
XF1	Moderate water saturation, without de-icing agent	Vertical concrete surfaces exposed to rain and freezing.

### Concrete in aggressive ground

Mixes should conform to BS 8500. The information in this section describes minimum specifications for lower range 'chemical aggressiveness'. Specialist advice should be sought for more aggressive conditions.

**Table 6:** Aggressive chemical environment for concrete (ACEC) site classification<sup>(1)</sup> and applies to concrete exposed to ground with a pH value greater than 2.5

Sulfate and magnesium				Natural soil		Brownfield <sup>(3)</sup>				ACEC class for site
Design sulfate class for site	2:1 water/soil extract	Ground water	Total potential sulfate <sup>(2)</sup>	Static water	Mobile water	Static water		Mobile water		
1	2	3	4	5	6	7	8	9	10	11
	SO <sub>4</sub>	Mg	SO <sub>4</sub>	Mg	SO <sub>4</sub>	pH	pH	pH <sup>(5)</sup>	pH <sup>(5)</sup>	
	mg/l	mg/l	mg/l	mg/l	%					
DS-1	<500	All Mg values	<400	All Mg values	<0.24	>2.5		>2.5		AC-1s
							>5.5 <sup>(6)</sup>		>6.5	AC-1
							2.5-5.5		5.5-6.5	AC-2z
									4.5-5.5	AC-3z
									2.5-4.5	AC-4z
DS-2	500-1500	All Mg values	400-1400	All Mg values	0.24-0.6	>3.5		>5.5		AC-1s
							>5.5		>6.5	AC-2
						2.5-3.5		2.5-5.5		AC-2s
							2.5-5.5		5.5-6.5	AC-3z
									4.5-5.5	AC-4z
									<4.5	AC-5z

#### Notes

- For concrete quality and APM for ACEC classes above AC-2z, follow specialist advice. For the full list of ACEC classes, refer to Table A.2 of BS 8500-1 or BRE Special Digest Part C Table C1 for natural ground locations, and Table C2 for brownfield locations.
- Applies only to sites where concrete will be exposed to sulfate ions (SO<sub>4</sub>), which may result from the oxidation of sulfides such as pyrite, following ground disturbance.
- Applies to locations on sites that comprise either undisturbed ground that is in its natural state or clean fill derived from such ground.
- 'Brownfield' is defined as sites which may contain chemical residues remaining from previous industrial use or from imported wastes.
- An additional account is taken of hydrochloric and nitric acids by adjustment to sulfate content.
- For flowing water that is potentially aggressive to concrete owing to high purity or an aggressive carbon dioxide level greater than 15mg/l, increase the ACEC class to AC-2z.

Explanation of suffix symbols to ACEC class number:

- Suffix 's' indicates that, as the water has been classified as static, no additional protective measures are generally necessary.
- Concrete placed in ACEC classes which include the suffix 'z' have primarily to resist acid conditions and may be made with any of the cements or combinations listed in Table D2 of BRE Special Digest 1.

This table is based on Tables C1 and C2 of BRE Special Digest 1.

The information in Table 7 provides guidance on selecting mixes for concrete elements in aggressive ground.

**Table 7:** Design guide for concrete elements in the ground

Concrete element	ACEC class <sup>(1)</sup>	Designated mix
Strip or trench fill foundation, raft foundation, pile <sup>(3)</sup> and ground beams.	AC-1, C1s	As Table 4
	AC-2, C2s	FND2 <sup>(2)</sup>
	AC-2z	FND2z <sup>(2)</sup>

#### Notes

- For all other ACEC classes, follow specialist advice.
- Portland limestone cement may only be used where the design sulfate class (see Table 5) of the site does not exceed DS-1.
- Applies to cast-in-situ piles only – for other types of pile refer to BRE Special Digest 1 or follow specialist advice.



### Exposure to sulfates and acids in groundwater

Sulfates, chemicals and high acidity can cause expansion, cracking and damage to concrete. Where ground water is highly mobile, or where concrete is at risk from chemical attack, the level of sulfate and other chemicals should be determined according to the ACEC class (aggressive chemical environment for concrete class) and BRE Special Digest 1.

For higher ACEC classes, specialist advice should determine the design chemical class (DC class) and appropriate additional protective measures (APM) where required. Table A.7 of BS 8500-1 should be used to select the mix specification.

For lower ACEC classes (AC-1, AC-1s, AC-2, AC-2s and AC-2z), information in Tables 6 and 7 should be used to select the mix specification.

### Effects of chlorides

Chlorides, which are contained in all concrete materials, increase the risk of corrosion in metal and can reduce the chemical resistance of concrete, therefore chloride content of fresh concrete should be limited in accordance with BS EN 206-1 Table 10.

Cured concrete can be damaged by chlorides in the ground, sea spray, or products used for de-icing highways, and specialist guidance should be followed.

### Effects of alkali-silica reaction

Alkalis can cause expansion, cracking and damage to concrete. Damage can occur when all the following conditions are present:

- a source of alkali
- a high moisture content
- where the aggregate is alkali reactive.

Alkali content calculated in accordance with BRE Digest 330 or Concrete Society Technical Report 30 should not exceed 3kg/m<sup>3</sup>. Where unfamiliar aggregate materials are used, special precautions may be required.

Standardised prescribed mixes should conform to BS 8500.

### Aggregates

Aggregates should be of a grade which ensures adequate durability of the concrete. Certain types of aggregate are shrinkable and require special precautions in mixing. Certain types of aggregate may be susceptible to alkali attack or excessive moisture movement.

Proprietary and recovered aggregates should only be specified where they have been assessed in accordance with Technical Requirement R3.

## Admixtures <sup>3.1.7</sup>

### **Admixtures shall only be used to enhance the performance and durability of concrete.**

Issues that should be taken into account include:

- improved workability
- waterproofing
- foaming agents
- accelerated strength
- retardation
- chlorides.

Admixtures should comply with BS EN 934-2 Admixtures for concrete mortar and grout - Concrete admixtures - Definitions, requirements, conformity, marking and labelling, should be used in accordance with BS EN 206-1 should be:

- specified only with full knowledge of their limitations and effects
- used only where permitted in the specification
- tested in trial mixes, where necessary
- added to the mix water to ensure complete dispersal
- dosed correctly
- used strictly in accordance with the manufacturer's instructions.

Accelerators produce early setting of the concrete, and plasticisers can improve concrete cohesion and the bond with reinforcement.

Air-entraining agents should not be used as an anti-freeze for fresh concrete. Though they can increase the frost resistance of cured concrete and are recommended for paths, drives and pavements which are likely to be exposed to freezing conditions.

Retarding agents can increase the risk of frost damage.

Admixtures containing chlorides can cause metal corrosion and should not be used in reinforced concrete.

### Special types of concrete <sup>3.1.8</sup>

**Special types of concrete shall be appropriate for their use.**

Proprietary concrete, no-fines or lightweight concrete should be of a quality and density appropriate for the conditions and use. Where no-fines concrete is used, a render, cover coat or cladding should be applied to the finished structure.

Proprietary methods of reinforcement, e.g. glass fibre, should be assessed in accordance with Technical Requirement R3.

Structural design should be in accordance with Technical Requirement R5 and the mix properly detailed.

### Design of reinforced concrete <sup>3.1.9</sup>

*Also see: BS EN 1992-1-2*

**Reinforced concrete shall be suitable for its intended use. Issues to take into account include:**

- |  |                    |
|--|--------------------|
| a) compliance with appropriate standards | d) fire resistance |
| b) end restraint                         | e) carbonation.    |
| c) concrete cover                        |                    |

Reinforced concrete should be designed by an engineer in accordance with Technical Requirement R5. BS 8103-4 can be used for the design of suspended ground floors in homes and garages.

#### Compliance with appropriate standards

The steel specification should indicate the steel type, grade and size. Drawings and bending schedules should be prepared in accordance with BS 8666 and include all necessary dimensions for completion of the sitework. Reinforcement should comply with the standards listed below.

<b>BS EN 1992-1</b>	'Design of concrete structures.'
<b>BS 4449</b>	'Steel for the reinforcement of concrete.' Specification
<b>BS 4482</b>	'Steel wire for the reinforcement of concrete products.' Specification
<b>BS 4483</b>	'Steel fabric for the reinforcement of concrete.' Specification
<b>BS 6744</b>	'Stainless steel bars for the reinforcement of and use in concrete.' Requirements and test methods
<b>BS 8103-1</b>	'Structural design of low-rise buildings.' Code of practice

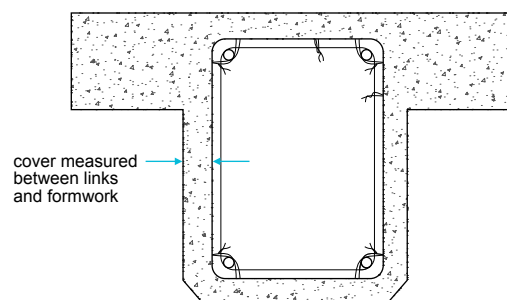
#### End restraint

Where the ends of slabs are cast monolithically with concrete members, surface cracking may develop over the supports. Reinforcement should therefore be provided in accordance with BS EN 1992-1-1.

#### Concrete cover

There should be adequate cover to the reinforcement, especially where it is exposed or in contact with the ground. Cover should be adequate for all reinforcement, including main bars and stirrups. No ties or clips should protrude into the concrete cover.

For concrete not designed by an engineer, the minimum cover for reinforcement should be in accordance with Table 8.



**Table 8:** Minimum cover for reinforcement for concrete not designed by an engineer

Position of the concrete	Minimum cover (mm)
In contact with the ground.	75
External conditions.	50
Cast against a DPM on sand blinding.	40
Against adequate blinding concrete.	40
Protected or internal conditions.	25

### Fire resistance

Concrete cover to reinforcement should be adequate to resist fire. Requirements for fire resistance are given in BS EN 1992-1-2. Cover required by BS EN 1992-1-1 will normally provide up to one hour of fire resistance for columns, simply supported beams and floors.

### Carbonation

Carbonation reduces the corrosion protection of the reinforcement by increasing porosity and decreasing alkalinity. Such corrosion can be reduced by providing as much concrete cover as possible, and by ensuring that the wet concrete is of good quality and properly compacted to reduce the rate of carbonation.

### Installation of reinforcement <sup>3.1.10</sup>

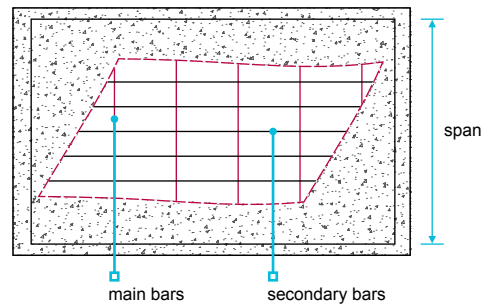
Also see: Chapter 5.2

**Reinforcement shall be installed in accordance with the design. Issues to take into account include:**

- a) shape, placing and condition of reinforcement bars
- b) lapping bars and mesh
- c) support for reinforcement.

### Shape, placing and condition of reinforcement bars

<b>Main reinforcing bars</b>	Should be parallel to the span, or as detailed in the design.
<b>Slab reinforcement</b>	Should be located near the bottom of the slab, with the main reinforcing bars placed first and the secondary bars on top.
<b>Beams</b>	Should have the main reinforcing bars placed inside the links.



Reinforcement should be:

- bent using appropriate equipment and placed in accordance with the design
- clean and free from loose rust and contaminants, especially shutter-releasing agents and oil.

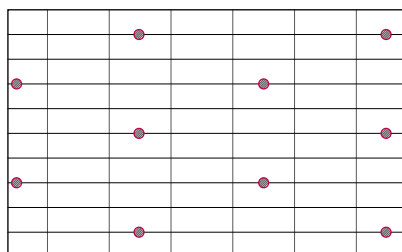
### Lapping bars and mesh

Reinforcing bars or mesh should be lapped according to type and size as indicated by the designer to ensure that loads are fully transferred across the lap. Any additional laps require the designer's approval.

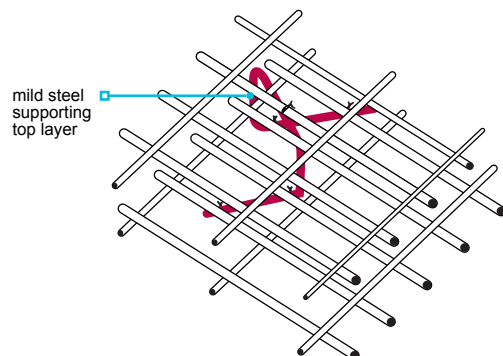
### Support for reinforcement

Spacers should be either concrete blocks (no more than 50 x 50mm) or ready-made of steel or plastic. Supports should be placed no more than one metre apart, or closer where necessary.

Spacers for parallel bars should be staggered to avoid creating a plane of weakness in the concrete. Supports for top steel should be chairs, or other proprietary products.



spacers staggered to avoid planes of weakness



### Blinding concrete <sup>3.1.11</sup>

**Blinding concrete shall be used where required to aid construction.**

Blinding concrete should only be used:

- to protect the bottom of the trench/excavation where there is a delay in pouring structural concrete
- where the foundation has been slightly overdug
- to provide sufficient support to ensure cover to reinforcement is maintained, or
- where localised soft spots have been removed.

### Formwork <sup>3.1.12</sup>

**Formwork shall be structurally adequate and constructed in a workmanlike manner.**

Formwork should be accurately set out in relation to relevant reference lines and benchmarks. Accuracy is essential to ensure that the correct cover to the reinforcement is maintained.

Formwork and its supports should be rigid enough to maintain the correct position and to withstand extra loads and accidental knocks likely to occur during placement and compacting. Wedges, inserts and boxes should be firmly secured to avoid displacement during vibration.

For concrete which is to be left untreated, or with minimum finishing, formwork joints should be tight to avoid grout loss and ragged edges. Joints between shutters should be constructed for easy stripping. Any holes for bolts or spacers should be drilled with care to avoid disfiguring or splintering the formwork surface and giving a poor finish.

Formwork should be capable of being struck without damage to the concrete. Formwork should be dismantled without shock, disturbance or damage to the concrete. Support for load-bearing elements should not be removed until the concrete has achieved sufficient strength, as detailed by the designer. Props under suspended floors or beams should be released from the centre, outwards, to avoid overloading.

### Before concreting <sup>3.1.13</sup>

**Installations and final preparations shall be completed before concreting starts.**

Before concreting starts:

- all services, ducts, inserts, etc. to be embedded in the concrete should be securely installed in the correct position and, where appropriate, tested
- completed reinforcement should be checked and, where necessary, approved by the designer or their representative
- formwork should be cleaned out and checked for fallen debris, especially nails and wire clippings.

### Casting <sup>3.1.14</sup>

*Also see: Chapter 3.2*

**Concrete shall be cast so as to achieve the required design strength and durability.**

The temperature of the concrete at the point of use should not be less than 5°C (41°F). Fresh concrete is susceptible to frost damage, and freezing can cause internal damage that is not immediately obvious.

Concrete should not be placed in or under water, unless it has been specially designed for that use.

Sufficient concrete should be mixed or ordered, so that it can be placed in a continuous process.

Concrete should be deposited as close as possible to its final location. Transportation on site should be as fast and efficient as possible in order to avoid segregation and to ensure full compaction of the placed concrete.

Site-mixed concrete should be placed within 30 minutes, and ready-mixed concrete within two hours, of water being added to the cement. Additional water should not be added to ready-mixed concrete unless under the supervision and approval of the supplier.

Concreting should, wherever possible, be carried out in one operation, taking account of:

- weather conditions
- available daylight
- time to allow for surface finishing.

Concrete cast in one operation (i.e. without construction joints) should always be as square in shape as possible and not greater than:

- reinforced concrete 60m<sup>2</sup>
- unreinforced concrete 16m<sup>2</sup>.

Construction joints should be formed only where unavoidable and in consultation with the engineer. These should not be positioned next to a return in the foundation. Before work continues beyond the joint, shuttering used to form the joint should be removed.

Reinforced concrete should be fully compacted using poker vibration unless the design states otherwise. Poker vibration should be carried out by experienced operators to ensure complete coverage and to avoid honeycombing. Vibrating beams or hand tamping may be used to consolidate slabs up to 150mm thick, unless the design details otherwise. Excessive use of vibration can cause segregation and prevent concrete reaching an adequate strength.

### Curing <sup>3.1.15</sup>

*Also see: Chapter 3.2*

#### Concrete shall be adequately cured to achieve full design strength.

Concrete performance relies on the curing process. The design should clearly indicate where there are any special requirements for curing concrete.

Freshly poured concrete should be kept moist by covering as soon as the surface is hard enough to resist damage. This is particularly important in hot, windy or cold weather to prevent the surface drying out too rapidly, or freezing. Damp hessian, damp sharp sand or an impervious sheet (such as polyethylene) are acceptable as surface coverings. Alternatively, a curing agent can be applied to the surface.

No load should be applied to the work until the concrete has cured sufficiently. It is recommended that plain unreinforced concrete made with ordinary Portland cement is left for at least four days to cure.

It is possible to proceed with substructure masonry above strip or trench fill foundations on unreinforced ordinary Portland cement concrete at an early stage, provided that care is taken to protect the surface from damage.

Reinforced concrete or concrete containing cement replacements, such as PFA, will require a longer curing period. This will normally take seven days, during which the concrete structure should not be loaded.

Any curing agents should comply with Technical Requirement R3 and should be applied strictly in accordance with the manufacturer's instructions. Curing agents should never be used on floors which are to receive either a topping or a screed, as it could affect the future bond. Curing periods may be extended at low temperatures.

### Testing <sup>3.1.16</sup>

#### Testing shall be carried out to the full satisfaction of NHBC.

Testing, where required, shall be conducted to BS EN 12390 by UKAS approved laboratories. Test cubes should be prepared as requested by the engineer. These should be marked, cured and stored safely until testing.

Proof of testing, with reports, certificates and allied documentation, should be kept for reference and made available to NHBC upon request.

Ready-mixed concrete supplier should prepare test cubes in accordance with quality assurance procedures.

### Glossary <sup>3.1.17</sup>

<b>Aggressive chemical environment for concrete classification (ACEC class)</b>	A system for the classification of aggressive ground conditions that are derived from design sulfate class. It takes into account the site (natural or brownfield) and the mobility and pH of ground water. Brownfield, 'mobile' water and low pH (acidic) conditions may have adverse effects on buried concrete and hence result in a more severe ACEC class.
<b>Additional protective measures (APM)</b>	These are defined as the extra measures that could be taken to protect concrete where the basic concrete specification might not give adequate resistance to chemical attack.
<b>Design chemical class (DC class)</b>	This defines the qualities of concrete that are required to resist chemical attack. The DC class is derived from the ACEC class of the ground and other factors, including the type of concrete element and its required structural performance.
<b>Design sulfate class (DS class)</b>	A site classification based on the determined sulfate (including potential sulfate) contents of the ground and/or ground water. It is also dependent on the type of site, presence or absence of magnesium ions, pyrite, and for pH less than 5.5, chloride and nitrate ions. Five levels of classification are given that are equivalent to those given in BRE Digest 363 (now superseded).
<b>Enhanced concrete quality</b>	An incremental step in concrete quality that could be used as an Additional Protective Measure (APM). Each increment in concrete quality is counted as an extra APM.
<b>Mobile ground water</b>	Sites where water is free to flow into an excavation to give a standing water level are affected by mobile ground water. The threshold ground permeability is greater than 10 <sup>-6</sup> m/s (i.e. 86 mm/day).
<b>Static ground water</b>	The sites where the free flow of water is confined due to either permanently dry conditions or the soil is relatively impermeable (of permeability less than 10 <sup>-6</sup> m/s).
<b>Total potential sulfate (TPS)</b>	The total potential sulfate content is the result of the combination of sulfates already present in the ground and that which may be added due to the oxidation of pyrite in the ground.

# Cold weather working

## CHAPTER 3.2

This chapter gives guidance on meeting the Technical Requirements for cold weather working.

3.2.1	Compliance	01
3.2.2	External conditions	01
3.2.3	Materials	01
3.2.4	Concreting	01
3.2.5	Masonry	02
3.2.6	Rendering, plastering and screeding	02
3.2.7	Admixtures	03
3.2.8	Painting	03



Raising Standards. Protecting Homeowners

### Compliance <sup>3.2.1</sup>

*Also see: Chapter 2.1*

#### **Cold weather working shall comply with the Technical Requirements.**

Sitework which complies with the guidance in this chapter will generally be acceptable.

### External conditions <sup>3.2.2</sup>

*Also see: Meteorological Office*

#### **Allowance shall be made for cold weather conditions during construction.**

Work should be planned in advance, and account taken of site and climatic conditions either by:

- stopping work, or
- taking adequate precautions.

The following conditions should be considered when scheduling work:

- Wind (this can create a cooling effect which can reduce temperatures further, i.e. affecting the curing of concrete and mortar).
- Shade (in particular high trees or adjacent buildings can block low winter sun and reduce temperatures further).
- Valleys (sites in valleys are susceptible to increased risk of frost).

Where air temperature is below, or likely to fall below, 2°C, work should not proceed unless the precautions detailed in this chapter are adopted.

A thermometer should be sited in the shade and used to indicate if temperatures are rising or falling.

### Materials <sup>3.2.3</sup>

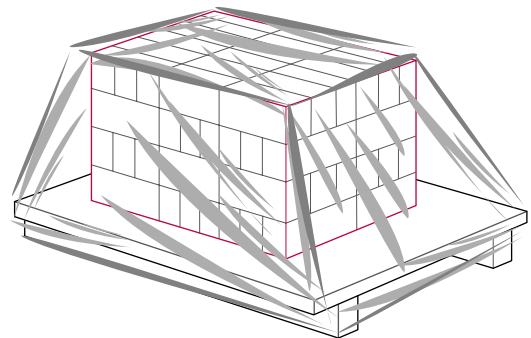
#### **Materials shall be adequately protected against cold weather.**

Materials should:

- not be used if frozen
- be protected using appropriate covers to prevent damage by snow, ice, frost or damp.

Appropriate covers should be provided for bricks and blocks, sand, aggregates and cement, to prevent them from becoming saturated and damaged by frost.

Where it is necessary to continue building during longer periods of colder weather, heaters should be used to protect materials.



### Concreting <sup>3.2.4</sup>

*Also see: BS EN 13670 Table 4 Curing class 2 and Table F1 Curing class 2*

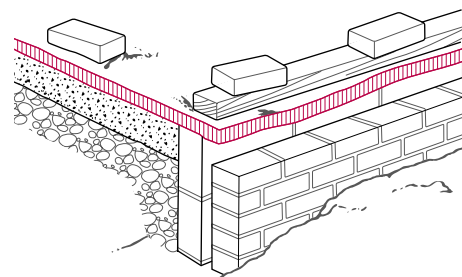
#### **Concrete shall not be placed in cold weather unless suitable precautions are taken.**

The minimum temperature of ready-mixed concrete when delivered should be 5°C, in accordance with BS EN 206-1.

When concreting is undertaken during colder weather, curing periods should be adjusted according to environmental conditions. Concrete should:

- be covered to maintain the temperature above freezing, and heated if necessary
- not be placed where the ground, oversite or the surfaces that will be in contact with the concrete are frozen
- be placed with caution where small quantities of fresh concrete are against a large volume of hardened concrete which is at a lower temperature.

Where slight overnight frosts are expected, 50mm of insulation held down firmly at the edges should be used to help protect oversite concrete. Where very severe frosts are expected, insulation alone is inadequate and heating should be provided.



**Site-mixed concrete**

If the air temperature drops to 2°C, concrete work should not proceed unless:

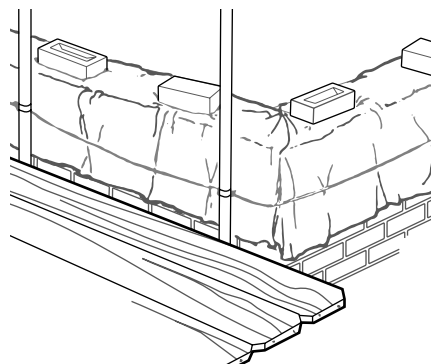
- the ground into which the concrete is to be placed is not frozen
  - the aggregate temperature is above 2°C
  - the aggregate is free of frost and snow
  - the water for mixing is heated, but not above 60°C (cement should not be heated)
  - the cast concrete can be properly protected, taking account of the cross-sectional area and location.
- In prolonged or very severe cold weather:
- covers will not stop severe frost penetrating the aggregate
  - where work is to continue, it may be necessary to steam heat aggregates or to use hot air blowers below covers
  - heating the mixing water cannot be relied upon to thaw frozen aggregates, and very cold aggregate can still remain frozen.

**Masonry** <sup>3.2.5</sup>

**Masonry shall not be laid in cold weather unless suitable precautions are taken.**

When laying masonry in cold weather:

- and temperatures are below, or are likely to fall below, 2°C (temperatures should be checked throughout the day on a thermometer), masonry should not be laid unless heating is provided and newly laid masonry protected
- materials which have been damaged by frost or are frozen should not be used
- additional covers and insulation will be necessary at very low temperatures
- polyethylene covers should be used to provide protection and prevent work from becoming saturated (an air gap between the masonry and the covers will enable new masonry to cure)
- where very severe frosts are expected, heaters may be required
- protection against frost may be required for up to six days, depending on the severity of the conditions.

**Rendering, plastering and screeding** <sup>3.2.6</sup>

*Also see: Chapter 6.11*

**Rendering, plastering and screeding shall not be carried out in cold weather unless suitable precautions are taken.**

Rendering, plastering and screeding should not be carried out if there is frost on the structure.

Where warm air heaters are used to warm the structure before screeding and plastering takes place, they should:

- keep the temperature of the structure above freezing during the curing period
  - not produce water vapour (the building should be ventilated to disperse moisture)
  - be placed in the room a day before plastering is to start
  - be used for longer following a prolonged cold period (as ground floors and walls near to floor level may be slow to respond)
  - continue heating for at least 48 hours after completion of the work but not be excessive (to avoid damage to screeds, plaster finishes and woodwork).
- Render should not be applied if:
- the temperature is below, or likely to fall below, 2°C (temperatures should be checked throughout the day on a thermometer)
  - backgrounds are saturated or frozen, or
  - there is a possibility that new work will be subjected to frost before it has set.



### Admixtures <sup>3.2.7</sup>

**Admixtures shall be used correctly and in accordance with the manufacturer's recommendations.**

When using admixtures:

- accelerators may assist the mortar or concrete to set before temperatures fall (admixtures do not prevent frost damage to uncured concrete or mortar)
- plasticisers can entrain air during mixing to provide frost resistance to mature mortar and concrete
- in cold weather, retarding agents should not be used as they can increase the setting times of cement
- in cold weather, bonding agents may be ineffective
- those containing calcium chloride should be avoided.

### Painting <sup>3.2.8</sup>

**Painting shall not be carried out when there is a risk of damage due to cold weather.**

Paint should not be applied:

- on surfaces affected by damp, frost or condensation
- where the air temperature is below, or likely to fall below, 2°C
- when condensation, snow or rain is likely to affect paintwork before it is dry.

# Timber preservation (natural solid timber)

## CHAPTER 3.3

This chapter gives guidance on meeting the Technical Requirements for the protection of natural solid timber against fungal decay when exposed to damp conditions and against insect attack.

3.3.1	Compliance	01
3.3.2	Durability	01
3.3.3	Sitework	03
3.3.4	Protection and storage	03
3.3.5	Treatment of cut surfaces	03
3.3.6	Compatibility with metal	03
3.3.7	Further information	03



Raising Standards. Protecting Homeowners

## Introduction

This chapter gives acceptable treatment schedules for the treatment of natural solid timber but does not cover:

- products such as plywood and wood particle boards
- the condition before the treatment
- treatment process techniques, which is the responsibility of the organisation carrying out the operation.

## Compliance 3.3.1

Also see: Chapter 2.1

**Timber preservative treatments and processes shall comply with the Technical Requirements and reasonably ensure that the timber is safely and satisfactorily protected against fungal decay and insect attack.**

Timber preservative treatments that comply with the guidance in this chapter will generally be acceptable. Timber and external joinery should either be:

- naturally durable and resistant to insect attack, or
- treated with preservative in accordance with this chapter.

It is important that treatment of timber and joinery is carried out to appropriate standards which are both suitable and safe. Treatments in accordance with procedures set out in British Standards, Codes of Practice, or which have been satisfactorily assessed by an independent authority in accordance with Technical Requirement R3, will generally be acceptable. The specification should state the specific treatment and standard required.

All preservatives should meet the requirements of the Control of Pesticides Regulations (1986) administered by the Health and Safety Executive. The safety instructions published by the manufacturers should be followed.

## Durability 3.3.2

**Timber and joinery used in the construction of homes shall either have adequate natural durability or, where treatment is undertaken, receive a satisfactory preservative treatment against fungal decay and insect attack.**

Timber component groups and preservative treatment required are shown in Table 1 below (based on BS 8417), which provides information to establish the appropriate type of treatment according to the particular element and conditions of use. Table 2 provides information on the timber species and durability.

**Table 1:** Timber component groups and preservative treatment

Component group	Examples	Use class	Desired service life	Preservative type required				Preservative treatment not required
				Copper organic <sup>(1)</sup>	Water-based organic <sup>(1)</sup>	Organic solvent or microemulsion <sup>(1)</sup>	Boron <sup>(2)</sup>	
Internal joinery, intermediate floor joists	Architraves, internal doors, intermediate floor joists	1	60	✓	✓	✓	✓	Unless a specific request for treatment against insect attack has been made.
Roof timbers (dry)	Pitched roofs: rafters, purlins, joists, wall plates	1	60	✓	✓	✓	✓	Unless a specific request for treatment against insect attack has been made.
Roof timbers (dry) in areas with house longhorn beetle	As above	1	60	✓	✓	✓	✓	Where timber used is: <ul style="list-style-type: none"> <li>■ softwood – heartwood only<sup>(3)</sup> and of durability class 1 – 3<sup>(4)</sup> or</li> <li>■ hardwood.</li> </ul>
Roof timbers (risk of wetting)	Flat roofs joists, sarking, tiling battens, valley boards, timbers exposed to risk of condensation, porch posts – coated and held clear of the ground and standing water, in a free draining shoe made from suitably durable material such as galvanized or stainless steel.	2	60	✓	✓	✓	✓	Where timber used is: <ul style="list-style-type: none"> <li>■ heartwood only<sup>(3)</sup> and of durability class 1 – 2<sup>(4)</sup></li> </ul>
Roof timbers (risk of wetting) in areas with house longhorn beetle	As above	2	60	✓	✓	✓	✓	Where timber used is heartwood only <sup>(3)</sup> and of durability class 1 – 2 <sup>(4)</sup> .

Table 1 (continued): Timber component groups and preservative treatment

Component group	Examples	Use class	Desired service life	Preservative type required				Preservative treatment not required
				Copper organic <sup>(1)</sup>	Water-based organic <sup>(1)</sup>	Organic solvent or microemulsion <sup>(1)</sup>	Boron <sup>(2)</sup>	
External walls/ ground floors	Timber frames, ground floor joists, I-beam studwork	2	60	✓	✓	✓	✓	Where timber used is heartwood only <sup>(3)</sup> and of durability class 1 – 2 <sup>(4)</sup> .
Sole plates <sup>(5)</sup>		2	60	✓	✓	✓	✓	Where timber used is heartwood only <sup>(3)</sup> and of durability class 1 – 2 <sup>(4)</sup> .
External joinery, coated (not in ground contact) <sup>(6)</sup>	Window frames, door frames, doors, cladding (coated), soffits, fascias, barge boards	3	30	<sup>(7)</sup>	<sup>(7)</sup>	✓	✓	Where timber used is heartwood only <sup>(3)</sup> and of durability class 1 – 2 <sup>(4)</sup> .
Uncoated external timbers (not in ground contact)	Decking (where the deck is up to 600mm from ground level) <sup>(8)</sup> , cladding (uncoated)	3	15	✓	✓	✗	✗	Where timber used is heartwood only <sup>(3)</sup> and of durability class 1 – 2 <sup>(4)</sup> .
Timber in contact with the ground	Decking timber in ground contact (where the deck is up to 600mm from ground level) <sup>(8)</sup>	4	15	✓	✗	✗	✗	Where timber used is heartwood only <sup>(3)</sup> and of durability class 1 – 2 <sup>(4)</sup> .
Timber in contact with the ground	Timber retaining walls up to 1m high and within garden areas <sup>(7)</sup>	4	15	✓	✗	✗	✗	Where timber used is heartwood only <sup>(3)</sup> and of durability class 1 – 2 <sup>(4)</sup> .
Timber in contact with the ground	Timber retaining walls greater than 1m high and within garden areas <sup>(7)</sup>	4	30	✓	✗	✗	✗	Where timber used is heartwood only <sup>(3)</sup> and of durability class 1 <sup>(4)</sup> .
Timber in contact with the ground	Timber retaining walls up to 600mm high and in a boundary situation <sup>(9)</sup>	4	30	✓	✗	✗	✗	Where timber used is heartwood only <sup>(3)</sup> and of durability class 1 <sup>(4)</sup> .

Notes

- 1.Preservative treatment of timber should be in accordance with the recommendations of BS 8417, Table 4.
- 2.Preservative treatment of timber should be in accordance with the recommendations of BS 8417, Table 5.
- 3.Almost always, packs of timber contain sapwood. It should be assumed that timber is sapwood and preservative treated accordingly unless the timber has been specifically selected as heartwood only.
- 4.Natural durability classes are given in Table 2.
- 5.Sole plates should be positioned above DPC. Preservatives used should be resistant to leaching or, for boron, treatment should be to full cross-section retention standard. Treatment should be carried out in accordance with BS 8417.
- 6.The hardwoods known as Meranti, Seraya or Lauan should be treated in the same way as European redwood / Scots Pine when used for joinery.
- 7.The pressure treatment process used for these types of preservative will cause timber to swell, so these treatments are generally not used for window or door frames and other uses where dimensional precision is required.
- 8.Decking that is more than 600mm in height should have a desired service life of 60 years. Reference should be made to Chapters 7.1 'Flat roofs and balconies' and 10.2 'Drives, paths and landscaping'.
- 9.Where timber structures more than 600mm high are used for retaining ground in boundary situations, they should be designed with a desired service life of 60 years. Reference should be made to Chapter 10.2 'Drives, paths and landscaping'.

Table 2: Natural durability of building timbers (heartwood only)

Durability class	1. Very durable	2. Durable	3. Moderately durable	4. Slightly durable	5. Not durable
Hardwoods	<ul style="list-style-type: none"> <li>■ Kapur (Sabah, Burma)</li> <li>■ Padauk (white, Andaman)</li> <li>■ Teak (Malaysian)</li> <li>■ Opepe</li> <li>■ Afromosia</li> <li>■ Greenheart</li> <li>■ Guarea</li> <li>■ Iroko</li> <li>■ Jarrah</li> <li>■ Okan</li> <li>■ Pyinkado</li> <li>■ Peroba</li> </ul>	<ul style="list-style-type: none"> <li>■ Oak (American white, European)</li> <li>■ Mahogany (American)</li> <li>■ Chestnut (sweet)</li> <li>■ Louro (red)</li> <li>■ Basralocus</li> <li>■ Ekki</li> <li>■ Karri</li> <li>■ Kempas</li> </ul>	<ul style="list-style-type: none"> <li>■ Keruing (Sabah, Malaysian)</li> <li>■ Oak (Tasmanian, Turkey)</li> <li>■ Mahogany (African)</li> </ul>	<ul style="list-style-type: none"> <li>■ Oak (American red)</li> <li>■ Elm (Dutch, English, white, rock, wych)</li> <li>■ Beech (silver)</li> </ul>	<ul style="list-style-type: none"> <li>■ Birch (silver, European, paper, yellow)</li> <li>■ Chestnut (European horse)</li> <li>■ Beech (European)</li> <li>■ Sycamore</li> <li>■ Alder</li> <li>■ Lime</li> </ul>

**Table 2 (continued):** Natural durability of building timbers (heartwood only)

Durability class	1. Very durable	2. Durable	3. Moderately durable	4. Slightly durable	5. Not durable
Softwoods	None	<ul style="list-style-type: none"> <li>■ Cedar (imported western red)</li> </ul>	<ul style="list-style-type: none"> <li>■ Larch (European, hybrid, Japanese, tamarack, western, maritime)</li> <li>■ Fir (North American Douglas, UK Douglas)</li> <li>■ Pine (Caribbean pitch, American pitch)</li> <li>■ Cedar (UK western red)</li> </ul>	<ul style="list-style-type: none"> <li>■ Pine (Canadian red, Corsican, jack, parana, ponderosa, radiata, Scots, southern, western white, yellow, lodgepole)</li> <li>■ Spruce (Eastern Canadian, Engelmann, European whitewood, Sitka, western white)</li> <li>■ Fir (noble, silver, balsam, grand)</li> <li>■ Hem-fir (USA and Canada)</li> <li>■ Redwood (European)</li> </ul>	None

### Sitework <sup>3.3.3</sup>

#### Sitework shall follow established good practice and workmanship.

Checks should ensure that, when timber is delivered to site, timber and joinery products have received the specified treatment. This should be stated on the delivery note.

### Protection and storage <sup>3.3.4</sup>

#### Timber and joinery shall be stored and protected to ensure it is in a suitable condition for use.

It is important when timber and joinery products are stored that they are:

- protected from damage immediately upon delivery
- protected from the weather
- stored off the ground
- stored to limit the risk of distortion
- stored to allow air to circulate.

### Treatment of cut surfaces <sup>3.3.5</sup>

#### Timber which has been preservative treated and cut shall be retreated on the cut surfaces.

Timber should not be cut after treatment, but where this is unavoidable, all such surfaces should be retreated with a suitable colour tinted preservative, to enable confirmation that re-treatment has occurred. Only in situations where colour tinting will affect the appearance of the timber fixed to the home will clear preservatives be acceptable.

Applied preservatives should be compatible with the original treatment.

### Compatibility with metal <sup>3.3.6</sup>

#### Measures shall be taken to prevent adverse effects from incompatibility between metal components and treated timber.

Copper-containing treatments can cause corrosion between mild steel and aluminium. Where moisture is expected, the following fittings should be used when in contact with timber treated with copper-containing preservatives:

- Occasional dampness – galvanised fittings
- Likely wetting – austenitic stainless steel fittings.

Timber treated with copper containing preservatives should be re-dried to a moisture content of 20% for at least seven days before being in contact with metal fittings.

### Further information <sup>3.3.7</sup>

- *BS 8417 'Preservation of Timber – Recommendations'*
- *BS EN 599 – Part 1 'Durability of wood and wood-based products – Performance of preventive wood preservatives as determined by biological tests'*
- *Part 1: 'Specification according to hazard class. Industrial Wood Preservation – Specification and Practice' ('WPA Manual') (2008)*
- *The Wood Protection Association, 5C Flemming Court, Castleford, West Yorkshire, WF10 5HW, UK, Tel: 01977 558274, Email: [info@wood-protection.org](mailto:info@wood-protection.org)*

# Land quality – managing ground conditions

## CHAPTER 4.1

This chapter gives guidance on meeting the Technical Requirements for assessing and managing land quality.

4.1.1	Compliance	01
4.1.2	Initial Assessment – desk study (all sites)	03
4.1.3	Initial Assessment – walkover survey (all sites)	04
4.1.4	Initial Assessment – results	04
4.1.5	Basic Investigation (sites where hazards are not identified or suspected)	05
4.1.6	Detailed Investigation (sites where hazards are identified or suspected)	05
4.1.7	Managing the risks (sites where hazards are found)	06
4.1.8	Unforeseen hazards	06
4.1.9	Documentation and verification	07
4.1.10	Guidance for investigations	07
4.1.11	Further information	08



Raising Standards. Protecting Homeowners

### Introduction

This chapter provides a framework for managing geotechnical and contamination risks, with the objective of ensuring that:

- all sites are properly assessed and investigated for potential geotechnical and contamination hazards
- foundations and substructure designs are suitable for the ground conditions
- sites are properly remediated where necessary or appropriate, and design precautions are taken
- appropriate documentation and verification is provided to NHBC.

### Compliance <sup>4.1.1</sup>

*Also see: Chapter 4.2*

**Assessment of the site and the surrounding area shall comply with the Technical Requirements.**

**Items to be taken into account include:**

- a) suitability of persons for the level of investigation
- b) geotechnical and contamination issues
- c) investigation procedures
- d) notification in writing to NHBC of hazardous ground conditions.

Ground investigations and management of risk that complies with the guidance in this chapter will generally be acceptable.

#### Suitable persons for the level of investigation

The following skills and knowledge are required from the person responsible for the Initial Assessment, Basic Investigation and documentation and verification. They should:

- understand the hazards that can affect the development and where they originate
- recognise the signs of potential hazards
- conduct a desk study and walkover survey
- collect information relating to such hazards on and adjacent to the site
- report the findings in a clear and concise manner
- determine when specialist advice and detailed testing is required.

The following criteria should be used as guidance for the appointment of a consultant or specialist responsible for Detailed Investigation, management of hazards, documentation and verification:

<b>Experience</b>	Similar types of site and development.
<b>Appropriate discipline (s)</b>	Understanding of all relevant skills required on the project and access to other disciplines, including geologists, hydrogeologists, toxicologists and environmental chemists.
<b>Legislation</b>	Understanding of legislation and liabilities associated with the site.
<b>Professional indemnity insurance</b>	Appropriate cover for the work being carried out.
<b>Health and safety</b>	Awareness of occupational hygiene issues and Health and Safety legislation.
<b>Quality assurance</b>	Use of a quality management system, including appropriately accredited laboratories.
<b>Project management</b>	Ability to manage a project team consisting of the appropriate disciplines.
<b>Site investigation</b>	Ability to design site investigation programmes, including soil sampling, testing and laboratory analysis.
<b>Risk management</b>	Ability to conduct risk assessments as required by the risk management process.
<b>Reporting and communication</b>	Ability to prepare comprehensive and well presented reports. Effective communication within their organisation and with the client, statutory authorities and the general public.
<b>Engineering design</b>	Understanding of effective risk reduction techniques, e.g. engineered foundations and substructure details of suitable remediation.

#### Geotechnical and contamination issues

Assessment should be carried out by direct investigation and examination of the ground, supplemented by laboratory testing where necessary, in order to determine the geotechnical and contamination characteristics of the site.

Specifically, where contamination is suspected or found, the site should be assessed using the Source-Pathway-Receptor framework (known as the pollutant linkage).

For land contamination to occur, a source, pathway and receptor must all exist. A written or diagrammatic representation of the land contamination (known as a Conceptual Model), should be produced to show the possible relationships between each.

## Procedure

The process to assess and manage the ground conditions is as follows:

### Initial Assessment

NHBC requires all sites to be assessed by a desk study and a walkover survey. The results should be used to determine whether or not hazards are known or suspected.

### Basic Investigation

Required to support the results of the Initial Assessment where hazards are not suspected.

### Detailed Investigation

Required where hazards are known or suspected.

### Further Assessment

Required after the Basic or Detailed Investigation has been conducted, to confirm that all objectives have been met. Where results are inconclusive, further investigation will be required.

### Hazards

Where hazards are identified, design precautions or remediation will be required to minimise their effects.

If any unforeseen hazards are found during the course of construction, further investigation may be required.

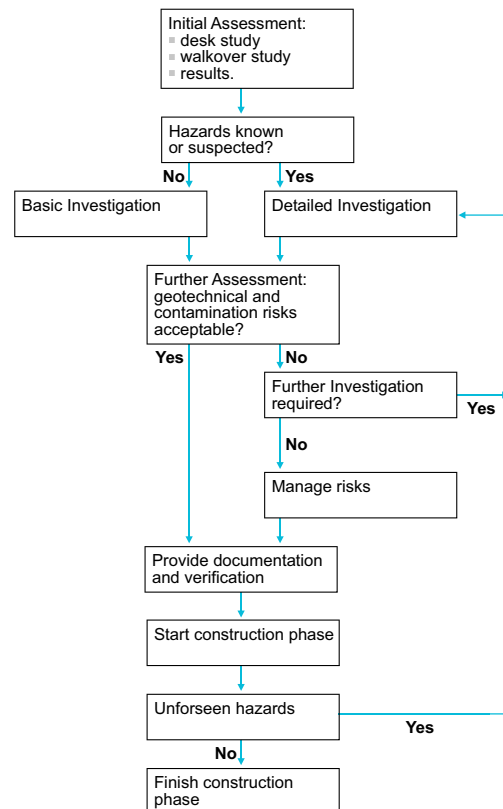
### Documentation and verification

NHBC requires documentation and verification to show that:

- the site has been properly assessed and investigated
- where necessary, suitable precautions are incorporated into the design
- all necessary remediation has been carried out.

### Notification of potential hazards and associated risks

If a site (defined in the Rules as an area of land that is covered by a single detailed planning consent or series of consents relating to continuous development) is classed as 'hazardous', NHBC must be notified in writing a minimum of eight weeks before work starts. Failure to provide such information may delay the registration process, the construction work and the issuing of NHBC warranty.





**Table 1:** Potential hazards and associated risks

Potential hazard	Associated risk
High water table or low-lying land	<ul style="list-style-type: none"> <li>■ flooding</li> <li>■ the effects from toxic or noxious materials which could be concentrated or transported by ground water.</li> </ul>
Mining (past, present and proposed)	<ul style="list-style-type: none"> <li>■ ground movement as a result of the type of mining and materials extracted</li> <li>■ ground gasses, including methane and carbon dioxide.</li> </ul>
Trees	<ul style="list-style-type: none"> <li>■ shrinkage and heave of clay soils</li> <li>■ physical damage caused by roots.</li> </ul>
Peat	<ul style="list-style-type: none"> <li>■ acid attack</li> <li>■ changes in volume due to variations in moisture content</li> <li>■ production of methane and carbon dioxide.</li> </ul>
Infill and made ground, including tipping	<ul style="list-style-type: none"> <li>■ release of gases which may be explosive or asphyxiating</li> <li>■ low bearing capacity causing excessive total and/or differential settlements</li> <li>■ consolidation characteristics which may result in subsidence, settlement and/or excessive tilt</li> <li>■ localised ground variability (laterally and with depth) which may result in subsidence, settlement and/or excessive tilt</li> <li>■ collapse compression or inundation settlement of non-cohesive fills which may result in subsidence, settlement and/or excessive tilt.</li> </ul>
Low bearing capacity ground	<ul style="list-style-type: none"> <li>■ settlement of foundations and substructures.</li> </ul>
Former buildings or structures	<ul style="list-style-type: none"> <li>■ underground obstructions producing variations in bearing capacity and settlement characteristics.</li> </ul>
Adjacent buildings	<ul style="list-style-type: none"> <li>■ effect on stability of both new and existing buildings.</li> </ul>
Drains, including land drains	<ul style="list-style-type: none"> <li>■ contamination, flooding, waterlogging and interruption of land drainage systems.</li> </ul>
Sulfates in ground or ground water	<ul style="list-style-type: none"> <li>■ expansive reaction</li> <li>■ chemical attack on concrete, mortar and bricks or blocks made with cement.</li> </ul>
Contamination	<ul style="list-style-type: none"> <li>■ from substances which may be carcinogenic, toxic, asphyxiating, corrosive, phytotoxic, combustive, explosive or radioactive.</li> </ul>
Solution features in chalk and limestone, including swallow holes	<ul style="list-style-type: none"> <li>■ underground cavities.</li> </ul>
Unstable ground subject to landslip	<ul style="list-style-type: none"> <li>■ ground movement.</li> </ul>
Seas, lakes and rivers adjacent to land	<ul style="list-style-type: none"> <li>■ erosion.</li> </ul>

### Initial Assessment – desk study (all sites) <sup>4.1.2</sup>

**A desk study of the site and the surrounding area, that covers key and existing site information, shall be undertaken by a suitable person and include investigation of soils, geology, surface water, ground water, current and historical uses.**

A desk study is the collection and examination of existing information obtained from a wide variety of sources. It should indicate potential hazards at an early stage and provide a basis for the investigation. Potential problems should be assessed according to the current and historical uses of the site and surrounding area, including those which may have been left by:

- industrial, commercial and agricultural uses, including storage
- mining
- quarrying
- landfilling and tipping.

Key information sources include:

- the Environment Agency or its equivalent – for example, coastal erosion, landfill sites, details of water abstraction
- the local authority – for example planning and environmental health
- British Geological Survey, maps and information
- Ordnance Survey, current and previous editions of plans and aerial photographs
- Coal Authority, mining reports – past, present and proposed mining
- utility companies
- county records offices, libraries, museums and local history sources
- soil survey maps
- the site vendor
- in-house information
- ongoing monitoring.

**Initial Assessment – walkover survey (all sites)** <sup>4.1.3</sup>

**To assess ground conditions, a walkover survey of the site and the surrounding area shall be undertaken by a suitable person.**

A walkover survey is a direct inspection of the site and the surrounding area carried out in conjunction with the desk study. Indications of any potential hazards should provide a basis for the investigation. A photographic record of the site can help in the reporting of the walkover survey.

**Table 2:** Potential hazards

Source of information	Items to be taken into account
Topography	<ul style="list-style-type: none"> <li>■ abrupt changes in slope</li> <li>■ valley bottoms or depressions which may be soft or filled</li> <li>■ evidence of overburden on slopes</li> <li>■ excavations at the base of the slope</li> <li>■ signs of landslip, e.g. tilting trees, posts or walls</li> <li>■ signs of subsidence</li> <li>■ evidence of imported soil including local surface depressions, tipped material or rubbish, particularly if it is hot or has an odour.</li> </ul>
Soils and rocks	<ul style="list-style-type: none"> <li>■ the basic ground type</li> <li>■ evidence of peat, silt or other highly compressible material at or below the surface</li> <li>■ cracking or stickiness of the surface which may indicate a shrinkable sub-soil</li> <li>■ sudden changes in conditions, e.g. clay to chalk or soil to rock.</li> </ul>
Surface water and vegetation	<ul style="list-style-type: none"> <li>■ a high water table indicated, e.g. by waterlogged ground</li> <li>■ signs of flooding</li> <li>■ reeds or water-loving plants</li> <li>■ springs, ponds, wells, ditches or streams</li> <li>■ the source of any discoloured water.</li> </ul>
Vegetation	<ul style="list-style-type: none"> <li>■ vegetation which may indicate the nature of the soils</li> <li>■ sparse dead or dying vegetation</li> <li>■ type and condition of vegetation on land adjoining the site</li> <li>■ species, height and condition of the trees</li> <li>■ species, height, spread and condition of hedges and scrub on clay</li> <li>■ evidence of former trees, hedges or scrub on clay.</li> </ul>
Structural information	<ul style="list-style-type: none"> <li>■ damage to structures, e.g. cracking in buildings, on or around the site</li> <li>■ other evidence of movement, e.g. tilting or distortion</li> <li>■ any structures or services below ground.</li> </ul>
Local information	<ul style="list-style-type: none"> <li>■ local knowledge of the site, e.g. mining, refuse tipping or flooding</li> <li>■ local industrial history records indicating past and present uses of the site</li> <li>■ place names and street names that may give clues to previous site usage, e.g. Brickfield Cottage, Water Lane.</li> </ul>

**Initial Assessment – results** <sup>4.1.4</sup>

**The results of the desk study and walkover survey shall be recorded and evaluated by a suitable person.**

Initial results should be evaluated for suspected hazards and the results recorded, and include the following as appropriate:

- site plans, including dates, previous and current uses, and proposed site layout
- geology of the site, including geological maps, previous site investigations and laboratory test results
- photographs, including aerial photographs, showing points of interest or concern (e.g. areas of ground instability), interpretation of aerial photographs, and dates of photographs
- list of sources of information consulted and copies of the information obtained.

### Basic Investigation (sites where hazards are not identified or suspected) <sup>4.1.5</sup>

Also see: BS EN 1997-2

**Where hazards are not suspected, a Basic Investigation of the site, including geotechnical and contamination investigations, shall be carried out by a suitable person and recorded to the satisfaction of NHBC.**

The Basic Investigation aims to provide assurance for all sites, regardless of how free of hazards they may appear, and forms the minimum requirement for a site investigation.

The number and depth of trial pits should be located so they are representative of the site and will depend upon the:

- proposed development
- nature of the site
- inconsistency of the soil and geology across the site.

Trial pits should be located outside the proposed foundation area, and generally be a minimum of 3m deep. The distance from the edge of the foundation should not be less than the depth of the trial pit. Where trial pits do not provide sufficient information, boreholes will be necessary.

Basic geotechnical and contamination investigations should be conducted and include:

- physical tests, such as plasticity index tests, to support the results of the Initial Assessment
- a basic contamination investigation based on sampling and testing of soil taken from trial pits during the geotechnical investigation.

During the excavation of the trial pits, the use of sight and smell may help to identify certain contaminants.

If the Basic Investigation reveals the presence of geotechnical and/or contamination hazards, or has not addressed all of the original objectives, or where there is any doubt about the condition of the ground, further Detailed Investigation should be conducted.

### Detailed Investigation (sites where hazards are identified or suspected) <sup>4.1.6</sup>

**Where hazards are identified or suspected, a Detailed Investigation of the site shall be conducted under the supervision of a consultant or specialist acceptable to NHBC to determine and report on the nature and extent of the conditions.**

A Detailed Investigation should be carried out where hazards are identified or suspected:

- from the outset
- from the initial results of the desktop study and walkover survey, or
- from the Basic Investigation.

A consultant or specialist acceptable to NHBC should be appointed to:

- design and supervise the Detailed Investigation
- present all the factual data obtained from the Detailed Investigation.

In addition to the Basic Investigation, the Detailed Investigation should adopt a clearly defined, structured approach, gathering information which considers the:

- immediate site and the adjacent area
- possibility of future development in the vicinity of the site
- nature of the development
- complexity of the ground conditions
- extent of influence of the proposed foundations
- presence of soil gas (if there is any possibility a full gas investigation should be carried out and include flow measurements)
- surface water and ground water conditions, soils and geology, and site history.

The problems and liabilities which have to be managed in order to develop the site should be clearly communicated in the Detailed Investigation report.

Further investigation should be conducted if the Detailed Investigation has not satisfactorily addressed all of the original objectives.

**Managing the risks (sites where hazards are found) 4.1.7**

**Hazardous ground conditions shall be satisfactorily managed under the supervision of a consultant or specialist acceptable to NHBC. Items to be taken into account include:**

- a) design precautions  
b) remediation techniques  
c) a method statement and report.

The consultant or specialist should:

- identify any results which show that design precautions and/or remediation may be necessary
- conduct a risk assessment to determine appropriate design precautions and/or remedial treatment
- specify the options for remediating any contamination that may be present and provide a remediation method statement
- make recommendations for appropriate design precautions as necessary, including all underground services on the site and any ground improvement techniques
- ensure the works are appropriately supervised
- produce a remediation report.

The proposed solutions for dealing with geotechnical and/or contamination hazards should make due allowance for any constraints that apply, for example:

- factors associated with the site and surrounding area which could restrict the design precautions or remediation techniques should be identified
- local and statutory requirements should be met to avoid abortive works
- time constraints may influence the choice of solution, but do not alter the requirement for effective remediation.

**Design precautions**

Solutions for dealing with geotechnical hazards include:

- specialist foundations such as rafts, piling and ground beams
- ground improvement techniques such as vibro, dynamic compaction and surcharging.

**Remediation techniques**

Solutions for dealing with contamination hazards include:

- risk avoidance by changing the pathway or isolating the target, by adjusting the layout and/or by building protective measures into the construction
- engineering-based treatments that remove or isolate contaminants or modify the pathway by excavation, providing ground barriers or covering and capping
- process-based treatment to remove, modify, stabilise or destroy contaminants by physical, biological, chemical or thermal means.

**Remediation method statement and report**

The remediation method statement should detail the strategy for the site and include the:

- original risk assessment, identification of the remediation objectives and outline information for the method chosen
- remediation objectives for ground, ground water and soil gas
- working method for implementing remediation
- waste classification and methods for control and disposal
- proposed supervision and monitoring of remediation
- validation sampling and testing to be implemented.

The report should include the following information:

- photographic records, especially for work which will be buried (e.g. membranes)
- site diaries or drawings, environmental supervisor's site diary and independent witness statements where appropriate
- accurate surveys of the levels and position of all remediated areas
- a description of any remedial materials used
- details of soil movements and waste transfer notes
- results of post-remediation sampling (laboratory certificates should be provided in appendices)
- validation test results
- results of monitoring
- details of all consultations and meetings with statutory authorities.

**Unforeseen hazards 4.1.8**

**Where additional or unforeseen hazards arise during construction, the builder shall ensure investigation and management satisfactory to NHBC.**

Where additional or unforeseen hazards arise, specialist advice is required so that the hazard is properly investigated, managed and verified.

### Documentation and verification <sup>4.1.9</sup>

**Documentation and verification shall be provided to to the satisfaction of NHBC demonstrate that the site is suitable for the proposed development. All relevant information, designs, specifications and reports shall be produced in a clearly understandable format and distributed to appropriate personnel.**

Where the site is within an area susceptible to radon, it will be necessary to follow appropriate guidance in the building regulations and associated documents. The information detailed in Table 3 should be provided to NHBC.

**Table 3:** Information required by NHBC

<b>Geotechnical hazards present:</b>	<b>Yes</b>	<b>No</b>	<b>Yes</b>	<b>No</b>
<b>Contamination hazards present:</b>	<b>Yes</b>	<b>Yes</b>	<b>No</b>	<b>No</b>
<b>Initial Assessment, Further Assessment and Basic Investigation</b>	■	■	■	■
<b>Detailed Investigation</b>	■	■	■	
<b>Proposals to manage geotechnical risks</b>	■		■	
<b>Proposals to manage contamination risks</b>	■	■		
<b>Verification evidence</b>	■	■	■	■

Note

Evidence may still be required by NHBC to substantiate that contamination and hazards are not present on the site.

### Guidance for investigations <sup>4.1.10</sup>

*Also see: BS EN 1997-2*

**Site investigations shall be undertaken in accordance with BS EN 1997-2 and recognised practice. Items to be taken into account include:**

- a) investigation technique
- b) sampling
- c) testing.

#### Investigation technique

A site investigation normally comprises techniques which are classed as either indirect or direct.

Indirect investigations use geophysical techniques, including electromagnetic, resistivity, seismic, gravity and ground radar, to interpret ground conditions. Conducted from the surface, they measure variations in properties of the ground, both horizontally and vertically, to define subsurface conditions. Geophysical methods rely on contrasts in the physical properties, for example, between sand and gravel and rockhead. Contrast may also be provided by faulting, underground cables and pipelines or by cavities.

Direct investigation techniques involve intrusive activities to enable the retrieval and examination of the ground using trial pits, trenches, boreholes or probes.

Trial pits allow the detailed inspection, logging, sampling and in-situ testing of large volumes of natural soil or fill and the assessment of ground water conditions. Trenches are extended trial pits, or linked trial pits, which are excavated where greater exposure of the ground conditions is required. Trial pits and trenches should be positioned where they will not affect future foundations.

Boreholes are typically formed using the following techniques:

<b>Light cable percussion drilling</b>	A shell and auger rig – typically used in the UK to drill boreholes in soils and weak rocks.
<b>Continuous flight auger</b>	Exploratory boreholes may be drilled in soils by mechanical continuous flight augers of various sizes. Hollow stem methods are typically employed where sample retrieval is required.
<b>Rotary drilling</b>	Either open-hole drilling or rotary coring, is used to investigate rock and sometimes stiff soils, such as boulder clay.
<b>Probing techniques</b>	Used to analyse the relative density of soils and for environmental sampling and monitoring (such as chemical and physical testing of gases, liquids and solids).

## Sampling

The number and type of samples taken should be:

- appropriate for the results of the desk study, the walkover survey and the site investigation
- appropriate for the range of ground materials encountered and the proposed development
- taken, stored and transported so that they avoid cross-contamination.

Samples are used to enable soil and rock descriptions to be made and to provide material for physical and chemical testing.

'Undisturbed' soil and rock samples undergo minimal disturbance, so provide a more reliable indication of the physical soil properties than 'disturbed' samples.

Ground water should be collected from appropriately designed monitoring wells which should be screened and sealed to ensure that the relevant stratum is being monitored.

Gas sampling should be carried out from appropriately designed monitoring wells, boreholes or window sampling holes are typically used. Identification of the probable source and the measurement of gas flow are important for risk assessments.

## Testing

Testing may be undertaken in-situ, or in a laboratory.

A wide variety of in-situ tests can be used to support the results of direct testing. These range from basic tests undertaken by geologists or engineers using simple hand-held devices or portable test kits to methods that require specialist personnel and equipment.

Testing laboratories should participate in quality assurance programmes and be accredited for relevant tests by bodies such as UKAS and MCERTS. Physical tests on soil and rock materials are carried out to provide the following information on ground:

- strength
- relative density
- deformation
- settlement
- consolidation characteristics
- permeability.

Chemical tests on soils, rocks, ground water and gases can be carried out to provide an indication of potential contamination on the site.

### Further information 4.1.11

- BRE: Report BR211 – 'Radon: Guidance on protective measures for new dwellings'
- Report BR212 – 'Construction of new buildings on gas-contaminated land'
- Report BR376 – 'Radon: guidance on protective measures for new dwellings in Scotland' Report BR413 – 'Radon: guidance on protective measures for new dwellings in Northern Ireland'
- Report BR414 – 'Protective measures for housing on gas contaminated land'
- Digest 383 – 'Site investigation for low-rise buildings: Soil description'
- BS 10175 – 'Investigation of potentially contaminated sites'
- BS EN ISO 14688 – 'Geotechnical investigation and testing. Identification and classification of soil: Part 1. Identification and description. Part 2. Principles for a classification'
- BS EN ISO 22476 – 'Geotechnical investigation and testing. Sampling methods and groundwater measurements. Part 1. Technical principles for execution'
- BS 8485 – 'Code of practice for the characterization and remediation of ground gas in affected development'
- C665 – 'Assessing risks posed by hazardous ground gasses to buildings'
- Special publications 101 – 112 – 'Remedial treatment for contaminated land'
- DCLG and its predecessor departments
- Approved Documents A and C – 'Structures and site preparation and resistance to contaminants and moisture'
- DEFRA and its predecessor departments
- CLAN 02/05 'Soil guideline values and the determination of land as contaminated land under Part 2A'
- Circular 01/2006 Environmental Protection Act 1990: Part 2A Contaminated Land
- Department of the Environment Industry Profiles – 'Information on the processes, materials and wastes associated with individual industries'
- Department of the Environment – Waste Management Paper No 27 – 'Landfill Gas: A technical memorandum on the monitoring and control of landfill gas'
- CLR11 'Model procedures for the management of land contamination'
- CLEA (Contaminated Land Exposure Assessment) guidance and software Science Reports SR 1,2,3 and 7
- 'Guidance for the safe development of housing on land affected by contamination'.

# Building near trees

## CHAPTER 4.2

This chapter gives guidance on meeting the Technical Requirements when building near trees, hedgerows and shrubs, particularly in shrinkable soils.

4.2.1	Compliance	01
4.2.2	Provision of information	01
4.2.3	Building near trees	02
4.2.4	The effects of trees on shrinkable soils	03
4.2.5	Foundations in all soil types	06
4.2.6	Excavation of foundations	06
4.2.7	Foundations in shrinkable soils	06
4.2.8	Design and construction of foundations in shrinkable soils	08
4.2.9	Foundation depths for specific conditions in shrinkable soils	09
4.2.10	Heave precautions	10
4.2.11	New drainage	13
4.2.12	Foundation depth charts	13
4.2.13	Foundation depth tables	16
4.2.14	Example	22
4.2.15	Further information	24



Raising Standards. Protecting Homeowners

### Introduction

The combination of shrinkable soils and trees, hedgerows or shrubs represents a hazard to structures that requires special consideration. Trees, hedgerows and shrubs take moisture from the ground and, in cohesive soils such as clay, this can cause significant volume changes resulting in ground movement. This has the potential to affect foundations and damage the supported structure. In order to minimise this risk, foundations should be designed to accommodate the movement or be taken to a depth where the likelihood of damaging movement is low.

This chapter gives guidance for common foundation types to deal with the hazard and includes suitable foundation depths which have been established from field data, research, NHBC data and practical experience. The depths are not those at which root activity, desiccation and ground movement are non-existent, but they are intended to provide an acceptable level of risk. However, if significant quantities of roots are unexpectedly encountered in the base of the trench, the excavation may need to be deepened.

The interaction between trees, soil and buildings is dependent on many factors and is inherently complex. The relationship becomes less predictable as factors combine to produce extreme conditions. These are signified by the need for deeper foundations. Depths greater than 2.5m indicate that conditions exist where prescriptive guidance is less reliable.

The services of a specialist arboriculturalist may be helpful for the identification of the type and condition of trees that may affect building work. This includes trees both on and adjacent to the site.

Consideration has been given to the potential effects of climate change in the guidance provided.

The following situations are beyond the scope of the guidance in this chapter and will require a site-specific assessment by an engineer (see Technical Requirement R5):

- Foundations deeper than 2.5m within the influence of trees.
- Ground with a slope of greater than 1 in 7 (approximately 8°) and man-made slopes such as embankments and cuttings.
- Underpinning.

### Compliance <sup>4.2.1</sup>

*Also see: Chapter 2.1*

**When building near trees, hedgerows or shrubs, all foundations shall comply with the Technical Requirements.**

Foundations near trees, hedgerows or shrubs that comply with the guidance in this chapter will generally be acceptable.

### Provision of information <sup>4.2.2</sup>

**Designs and specifications shall be produced in a clearly understandable format, include all relevant information and be distributed to appropriate personnel.**

The site plan should show the trees and hedgerows that affect the ground and works, as well as the type, depth and dimensions of the foundations that fall within their influence. Where trees or hedgerows are either not shown or are in different positions and shrinkable soil is identified, it may be necessary to adjust the foundation depths on site.

All necessary dimensions and levels should be indicated and relate to at least one benchmark and reference points on the site.

Details should be provided with respect to:

- |  |   |
|--|---|
| <ul style="list-style-type: none"> <li>■ technical method statements</li> <li>■ critical sequences of construction</li> <li>■ site layout</li> <li>■ site investigation</li> <li>■ soil volume change potential</li> <li>■ survey, including location and height of trees and hedgerows affecting the site</li> <li>■ tree species (including existing, removed and proposed) using English names</li> </ul> | <ul style="list-style-type: none"> <li>■ original and final ground levels</li> <li>■ planting schedules</li> <li>■ dimensions, type and depth of foundations</li> <li>■ locations and detailing of steps in foundations, movement and construction joints, ducts and services passing through the foundations</li> <li>■ location of services</li> <li>■ design of drainage systems.</li> </ul> |
|--|---|



**Building near trees** <sup>4.2.3</sup>

*Also see: Technical Requirements R5 and BS 5837*

**When building near trees, hedgerows or shrubs, the designs shall take account of:**

- a) physical growth of young trees
- b) protection of remaining trees and hedgerows
- c) removal of existing trees and hedgerows.

Before the site is cleared, a survey is required to record the location, heights and species of trees, hedgerows and shrubs on and adjacent to the site, which may affect the proposed development.

If the location of previously removed vegetation is not known, local enquiries and reference to aerial photographs should be carried out. Alternatively, the design should assume the worst conditions, or an engineer consulted to undertake a site-specific design based on all relevant information and in accordance with Technical Requirement R5.

Where root growth is noted within shrinkable soil and where records are not available, an engineer should be consulted to assess whether volume change is likely.

**Physical growth of young trees**

Damage to foundations resulting from the growth of trees and roots should be avoided by locating structures and services at a safe distance. Where this cannot be achieved, precautions which allow for future growth should be taken which include:

- reinforcing foundations to resist lateral forces
- bridging walls or structural slabs over the roots, allowing sufficient clearance or reinforcing to avoid cracking
- laying paving and other surfaces on a flexible base to allow for some movement.

**Protection of remaining trees and hedgerows**

Roots often extend to distances in excess of the height of the tree, the majority are within 600mm of the surface and project radially. All parts of the system are easily susceptible to damage which may not regenerate and which can affect the stability of the tree. This can be caused by:

- stripping topsoil too close to trees
- excavating trenches for foundations and services too close to trees
- raising soil levels adjacent to trees, particularly where non-granular materials are used
- the compaction of soil around trees by heavy plant
- the storage of heavy materials around trees
- covering the rooting area with impervious surfaces.

Trees should be protected from damage by:

- a fence or barrier. The fence or barrier should extend around a single trunk equivalent to a circle of radius 12 times the trunk diameter measured 1.5m above ground level. The shape of this area may change depending on specific factors such as local drainage, soil type, age and species of the tree. An arboriculturist may be required to assess these factors
- ensuring services are not routed close to trees or, where this is impractical, are installed in such a way as to minimise root damage.

**Removal of existing trees and hedgerows**

Statutory Requirements, planning conditions, conservation area restrictions or tree preservation orders may result in protected trees and hedgerows being retained. The local planning authority should be consulted.

Dead trees and hedgerows should be removed. Unstable trees should be made steady or felled. If necessary, specialist advice should be obtained from a registered arboriculturalist.

### The effects of trees on shrinkable soils <sup>4.2.4</sup>

Also see: *Arboricultural Advisory and Information Service, Arboricultural Association, BRE Digest 240 and local geological survey maps*

**Foundations shall be designed to make allowance for the effect of trees, hedgerows and shrubs on shrinkable soils. Items to be taken into account include:**

- soil classification, shrinkage and heave
- water demand, tree heights and zone of influence of trees
- climate.

#### Soil classification, shrinkage and heave

Shrinkable soils, that are widely distributed throughout the UK, often change volume as moisture content fluctuates seasonally and as a result of factors, including the action of tree roots. The resulting shrinkage or swelling can cause subsidence or heave damage to foundations, the structures they support and services.

The following definitions are used to classify soil properties:

<b>Shrinkable soils</b>	Over 35% fine particles and a Modified Plasticity Index of 10% or greater.
<b>Fine particles</b>	Nominal diameter less than 60µm, i.e. clay and silt particles.
<b>Plasticity Index (Ip)</b>	A measure of volume change potential determined by Atterberg Limits tests. These tests are carried out on the fine particles and any medium and fine sand particles. Soil particles with a nominal diameter greater than 425µm are removed by sieving beforehand and the smaller particles analysed. This is a requirement of BS 1377 which specifies the test procedure.
<b>Modified Plasticity Index (I'p)</b>	Defined as the Ip of the soil multiplied by the percentage of particles less than 425µm. $I'p = \frac{Ip \times \% \text{ less than } 425\mu\text{m}}{100\%}$

**Table 1:** Modified Plasticity Index related to volume change potential

Modified Plasticity Index	Volume change potential
40% and greater	High
20% to less than 40%	Medium
10% to less than 20%	Low

Alternatively, the Plasticity Index may be used without modification. For pure clays and other soils with 100% of particles less than 425µm, the result will be the same. However, for mixed soils such as glacial tills, use of the Modified Plasticity Index may result in a more economic design.

The volume change potential should be established from site investigation and reliable local knowledge of the geology. Sufficient samples should be taken to provide confidence that the results are representative. High volume change potential should be assumed if the volume change potential is unknown.

#### Water demand, tree heights and lateral zone of tree influence

Water demand varies according to tree species and size. Water demand categories of common tree species are given in the table below.

Where the species of a tree has not been identified, high water demand should be assumed.

Where the species of a tree has been identified but is not listed, the assumptions about water demand as listed in Table 2 may be made for broad-leafed trees:

**Table 2:** Water demand of broad-leaf trees by species

Tree species	Water demand
All elms, eucalyptus, hawthorn, oaks, poplars and willows	High water demand
All others	Moderate water demand

Table 3 shows the water demand categories and the average mature heights to which healthy trees of the species may be expected to grow in favourable ground and environmental conditions. This information:

- should be used for trees that are to remain or are scheduled to be planted
- may be used even when actual heights are greater.

**Table 3:** Water demand of tree species in relation to their height

High water demand species	Mature height (m)	Moderate water demand species	Mature height (m)	Low water demand species	Mature height (m)
<b>Broad-leaved trees:</b>					
English elm	24	Acacia (False)	18	Birch	14
Wheatley elm	22	Alder	18	Elder	10
Wych elm	18	Apple	10	Fig	8
Eucalyptus	18	Ash	23	Hazel	8
Hawthorn	10	Bay laurel	10	Holly	12
English oak	20	Beech	20	Honey locust	14
Holm oak	16	Blackthorn	8	Hornbeam	17
Red oak	24	Japanese cherry	9	Laburnum	12
Turkey oak	24	Laurel cherry	8	Magnolia	9
Hybrid black poplar	28	Orchard cherry	12	Mulberry	9
Lombardy poplar	25	Wild cherry	17	Tulip tree	20
White poplar	15	Horse chestnut	20		
Crack willow	24	Sweet chestnut	24		
Weeping willow	16	Lime	22		
White willow	24	Japanese maple	8		
		Norway maple	18		
		Mountain ash	11		
		Pear	12		
		Plane	26		
		Plum	10		
		Sycamore	22		
		Tree of heaven	20		
		Walnut	18		
		Whitebeam	12		
<b>Coniferous trees:</b>					
Lawson's cypress	18	Cedar	20		
Leyland cypress	20	Douglas fir	20		
Monterey cypress	20	Larch	20		
		Monkey puzzle	18		
		Pine	20		
		Spruce	18		
		Wellingtonia	30		
		Yew	12		

Tree identification can be assisted by reference to a tree recognition book. Information may be obtained from suitable alternative authoritative sources for trees not listed in this chapter.

When the species is known but the subspecies is not, the greatest height listed for the species should be assumed.

Where hedgerows contain trees, their effect should be assessed separately and the height of the species likely to have the greatest effect should be used.

**Table 3a:** Guidance for factors affecting the mature height and water demand of trees

Influencing factor	Guidance
Heavy crown reduction or pollarding (previously or planned)	The mature height should be used, or a registered arboriculturalist should be consulted to undertake a site-specific assessment.
Removal of trees (previously or planned)	The water demand of a semi-mature tree may be equal to that of a mature tree, though for a sapling or young tree will be significantly less.

Height H should be determined in accordance with this diagram when:

- deriving foundation depths when trees have been removed, based on tree height at the time of removal
- checking the appropriate level from which depths should be measured when trees remain and the ground level is increased, based on tree height at time of construction relative to original ground level, or
- determining if heave precautions are to be provided, based on tree height at time of construction.

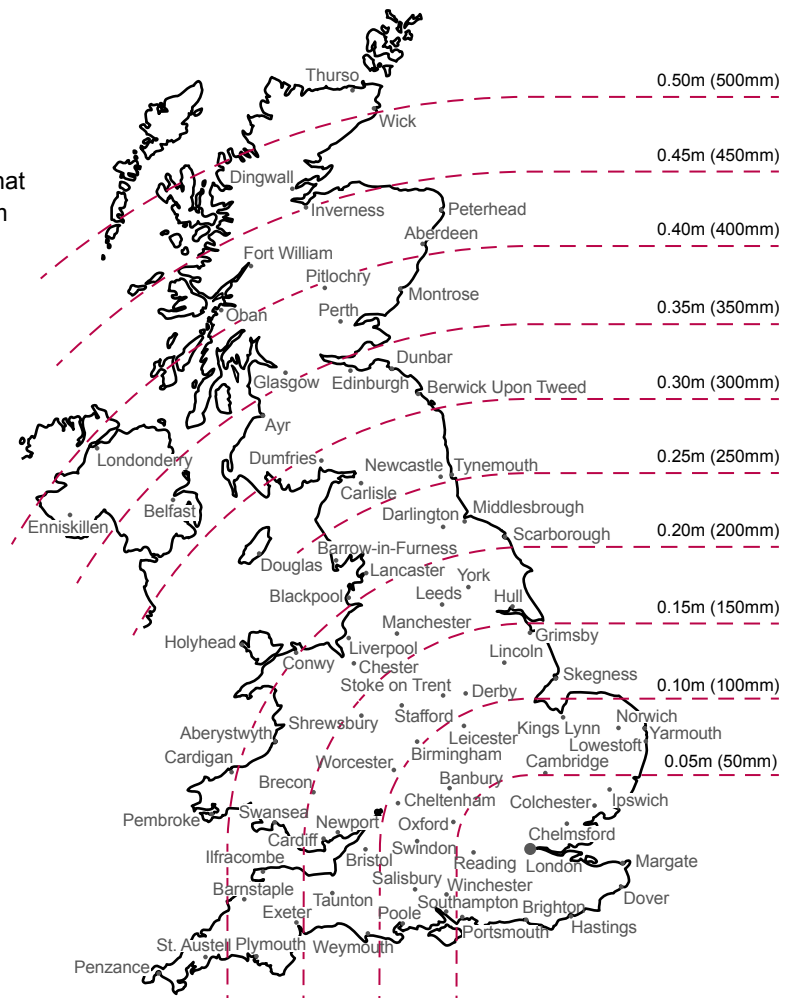
**Table 3b:** Zone of influence (lateral extent) of trees.

Water demand	Zone of influence
High	1.25 x mature height
Moderate	0.75 x mature height
Low	0.5 x mature height

**Climate**

High rainfall reduces moisture deficits caused by trees and hedgerows, while cool, damp weather reduces the rate of water loss from trees thus reducing the risk of soil movement.

The driest and hottest areas in the UK generally exist in southeast England; therefore, the greatest risk occurs in that area and diminishes with distance north and west. A 50mm decrease can be made to the foundation depth determined in accordance with this chapter for every 50 miles distance north and west of London. Where it is unclear which zone applies, the lower reduction value should be used.



### Foundations in all soil types <sup>4.2.5</sup>

**Foundations in all soil types shall be appropriately designed and constructed to transmit loads to the ground safely and without excessive movement.**

Different foundation types should not be used to support the same structure unless the foundation and superstructure design are undertaken by an engineer.

Freestanding masonry walls should be constructed on foundations in accordance with this chapter or designed to accommodate potential ground movement, for example, by careful use of movement joints and reinforcement.

### Excavation of foundations <sup>4.2.6</sup>

*Also see: Chapter 4.1, 4.3, 4.4, 4.5 and Technical Requirement R5*

**Excavation of foundations shall take account of the design and be suitable to receive concrete.**

Where trench bottoms become excessively dried or softened due to rain or ground water, the excavation should be re-bottomed prior to concreting.

Foundation depths should be measured on the centre line of the excavation and from ground level determined from Clause 4.2.9.

Some root activity may be expected below the depths determined in accordance with this guidance. However, if significant quantities of roots are unexpectedly encountered in the base of the trench, an engineer should be consulted to determine if the excavation should be deepened.

### Foundations in shrinkable soils <sup>4.2.7</sup>

*Also see: NHBC Foundation Depth Calculator App. [www.nhbc.co.uk/apps](http://www.nhbc.co.uk/apps)*

**Foundations shall be capable of accommodating the effects of trees, shrubs and hedgerows on shrinkable soils without excessive movement. Items to be taken into account include:**

- a) foundation type
- b) distance between tree and foundation
- c) method of assessment of foundation depths
- d) foundation depths related to the zone of influence of new tree planting
- e) foundation depths related to new shrub planting.

Landscape and foundation designs should be compatible, and planting schedules produced by a qualified landscape architect or other suitably qualified person and agreed with the local planning authority before work commences on site.

#### Foundation type

Foundations to all permanent structures, including garages, porches and conservatories, should take account of the effects of soil desiccation. Foundation types that are acceptable in shrinkable soils include strip, trench fill, pier and beam, pile and beam, and raft, providing they:

- are capable of supporting the applied loads without undue settlement
- include suitable heave precautions.

Variations to the foundation depths derived from this chapter may be permitted where:

- it is necessary to take account of local ground conditions
- designed in accordance with Technical Requirement R5.
- other foundation depths are traditionally acceptable

Root barriers are not an acceptable alternative to the guidance given.

#### Distance between tree and foundation

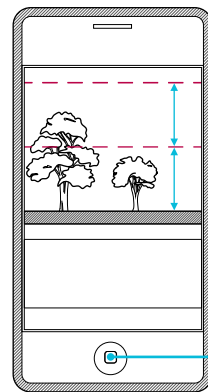
The distance (D) between the centre of the trunk and the nearest face of the foundation should be used to derive the foundation depths.

$D = 2m$  where trees which have been, or are to be, removed from within 2m of the face of the proposed foundation are less than 50% of the mature height as given in Table 3. This is to avoid a situation where, for example, a 'sapling' removed from the foundation line would otherwise require an unnecessarily deep foundation since the D/H value would always be zero, regardless of the height H of the tree.

### Method of assessment of foundation depths

Foundation depths should be determined according to the guidance provided in this document. If in doubt, assume the worst conditions or consult an engineer. Foundations deeper than 2.5m should be designed by an engineer in accordance with Technical Requirement R5.

One of the following methods may be used to assess the foundation depth where foundations are in the zone of influence of existing or proposed trees.



Foundation Depth Calculator App.  
[www.nhbc.co.uk/apps](http://www.nhbc.co.uk/apps)

Method	Taking account of	Comments
Design in accordance with this chapter to a depth derived from the charts in Clause 4.2.12, tables in Clause 4.2.13 or the Foundation Depth Calculator App	<ul style="list-style-type: none"> <li>■ site investigation</li> <li>■ soil volume change potential</li> <li>■ water demand of the tree</li> <li>■ appropriate tree height (H)</li> <li>■ distance (D) of the tree(s) from the foundations</li> <li>■ geographical location of the site north and west of London</li> <li>■ appropriate heave precautions.</li> </ul>	The most onerous conditions should be assumed in the absence of derived information.
Design by an engineer in accordance with Technical Requirement R5	<ul style="list-style-type: none"> <li>■ the recommendations of this chapter</li> <li>■ site investigation</li> <li>■ advice, when necessary, from a registered arboriculturalist or other competent person whose qualifications are acceptable to NHBC.</li> </ul>	When this method is used and it results in foundation depths or other details less onerous than those derived from this chapter, the design should be submitted to NHBC for approval prior to work commencing on site.

### Foundation depths related to the zone of influence of new tree planting

Foundation depths relating to the zone of influence of proposed tree planting should be in accordance with any of the following:

- Foundation depth charts in Clause 4.2.12.
- Tables in Clause 4.2.13.
- The Foundation Depth Calculator App.

Minimum foundation depths outside of the zone of influence of trees can be determined from Tables 4 and 5.

**Table 4:** Minimum foundation depths

Volume change potential	A) Minimum foundation depth (m) (allowing for restricted new planting)	B) Minimum foundation depth (m) (where planting is outside the zone of influence of trees)
High	1.50	1.0
Medium	1.25	0.9
Low	1.0	0.75

**Table 5:** Where foundation depths are in accordance with column A or column B in Table 4, tree planting should be restricted to:

Water demand	No tree planting zone for column A in Table 4	No tree planting zone / zone of influence for column B in Table 4
High	1.0 x mature height	1.25 x mature height
Moderate	0.5 x mature height	0.75 x mature height
Low	0.2 x mature height	0.50 x mature height

### Foundation depths related to new shrub planting

Shrubs have considerable potential to cause changes in soil moisture content. The foundation design should consider shrub planting in accordance with Table 6.

**Table 6:** Shrub planting

Volume change potential	A) Minimum foundation depth (m)	B) Minimum foundation depth (m)
High	1.50	1.0
Medium	1.25	0.9
Low	1.0	0.75

The foundation design should consider shrub planting as follows:

<b>Shrubs that have a maximum mature height of 1.8m</b>	Use foundation depth from column <b>B</b> .
<b>Climbing shrubs which require wall support and have a maximum mature height of 5.0m</b>	Use foundation depth from column <b>B</b> .
<b>Pyracantha and cotoneaster whose mature height exceeds 1.8m</b>	Use foundation depth from column <b>B</b> and plant at least 1.0 x mature height from foundation, or use foundation depth from column <b>A</b> and plant at least 0.5 x mature height from foundation.
<b>All others</b>	Use foundation depth from column <b>B</b> and plant at least 0.75 x mature height from foundation, or use foundation depth from column <b>A</b> with no restriction on minimum distance from foundation.

## Design and construction of foundations in shrinkable soils <sup>4.2.8</sup>

*Also see: Chapters 4.3, 4.4 and Technical Requirement R5*

### **Foundations in shrinkable soils shall be appropriately designed and constructed.**

Reference should be made to Clause 4.2.10 to establish the precautions necessary to cater for potential heave.

The following will only be acceptable if they are designed by an engineer and account for all potential movement of the soil on the foundations and substructure:

- Trench fill foundations deeper than 2.5m.
- Pier and beam foundations.
- Pile and beam foundations.
- Rafts.

#### **Trench fill foundations**

If trench fill foundations are deeper than 2.5m:

- the instability of the trench sides can lead to serious construction difficulties
- the design should take account of soil desiccation and the associated arboricultural advice
- additional heave precautions may be necessary to cater for lateral and shear forces acting on large vertical areas of foundation
- concrete overspill or overbreak in excavations should be avoided in order to reduce the possibility of additional vertical forces being transmitted to the foundation
- compressible material should be correctly placed to avoid excessive heave forces being applied to the foundations
- construction joints need to be detailed to account for increased lateral forces.

#### **Pier and beam foundations**

Pier depths not exceeding 2.5m depth may be derived from Clause 4.2.7. Pier depths greater than 2.5m require site specific assessment.

#### **Pile and beam foundations**

When selecting and designing pile and ground beam foundations, piles should be:

- designed with an adequate factor of safety to resist uplift forces on the shaft due to heave.
- reinforced for the length of the member governed by the heave design.

Sufficient anchorage should be provided below the depth of desiccated soil. Slip liners may be used to reduce uplift but the amount of reduction is small, as friction between materials cannot be eliminated.

Bored, cast-in-place piles are well suited to counteracting heave. Most types have a straight-sided shaft, while some are produced with a contoured shaft to increase load capacity. The design should allow for the enhanced tensile forces in these piles.

Driven piles are less well suited to counteracting heave and are difficult to install in stiff desiccated clay without excessive noise and vibration. The joint design of these piles should be capable of transmitting tensile heave forces.

Ground beams should be designed to account for the upward forces acting on their underside and transmitted from the compressible material or void former prior to collapse, and in accordance with the manufacturer's recommendations.

### Raft foundations

Raft foundations in shrinkable soils will only be acceptable where all of the following apply:

- design is by an engineer in accordance with Technical Requirement R5
- NHBC is satisfied that the raft is sufficiently stiff to resist differential movements
- NHBC is satisfied that the raft is founded on granular infill placed and fully compacted in layers and in accordance with the engineer's specification. Where required by NHBC, site inspections are to be undertaken by the engineer to verify suitable compaction of the fill
- the raft is generally rectangular in plan with a side ratio of not more than 2:1
- foundation depth is derived in accordance with Clause 4.2.7, and is less than 2.5m.

### Foundation depths for specific conditions in shrinkable soils <sup>4.2.9</sup>

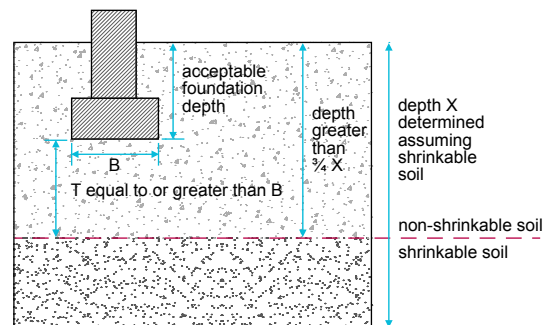
**Foundations in shrinkable soils shall be designed to transmit loads to the ground safely and without excessive movement. Items to be taken into account include:**

- a) strip and trench fill foundations in non-shrinkable soils overlying shrinkable soil
- b) measurement of foundation depths
- c) granular infill beneath raft foundations in shrinkable soils
- d) steps in foundations.

#### Strip and trench fill foundations in non-shrinkable soils overlying shrinkable soil

Non shrinkable soils such as sands and gravels may overlie shrinkable soil. Foundations may be constructed on overlying non-shrinkable soil if all the following are satisfied:

- Conditions of Chapter 4.3 'Strip and trench fill foundations' are met.
- Consistent soil conditions exist across each plot and this is confirmed by the site investigation.
- Depth of the non-shrinkable soil is greater than  $\frac{3}{4}$  foundation depth  $X$ , where  $X$  is the foundation depth determined using charts in Clause 4.2.12, tables in Clause 4.2.13 or the Foundation Depth Calculator App, assuming all the soil is shrinkable.
- The thickness  $T$  of non-shrinkable soil below the foundation is equal to, or more than, the width of the foundation  $B$ .
- Proposals are submitted to, and approved by, NHBC prior to work commencing on site.



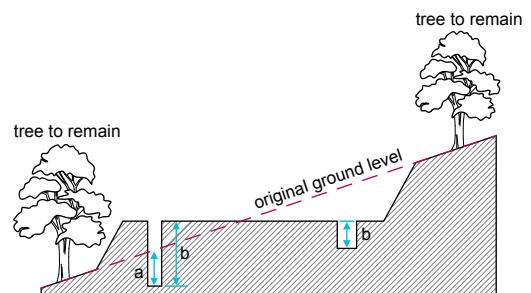
Where any of the above are not met foundation depths should be determined as for shrinkable soil.

#### Measurement of foundation depths

Where ground levels are to remain unaltered, foundation depths should be measured from original ground level.

Measurement of foundation depths where ground levels are reduced or increased, either in the recent past or during construction, should be as shown in figures 1, 2 and 3.

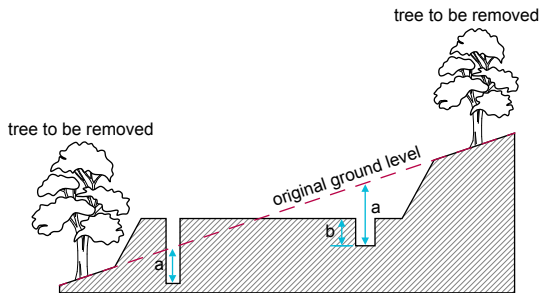
**Figure 1:** Levels from which foundation depths are measured where trees or hedgerows are to remain



Use the lower of:  
a) foundation depth based on appropriate tree height (see Table 3a)  
b) foundation depth based on mature height of tree.

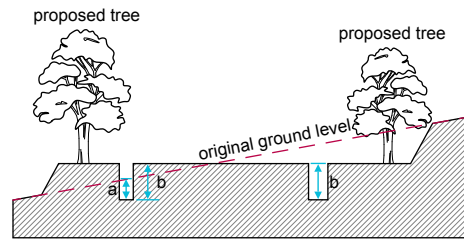


**Figure 2:** Levels from which foundation depths are measured where trees or hedgerows are removed



Use the lower of:  
 a) foundation depth based on appropriate tree height (see Table 3a)  
 b) minimum foundation depth (see Table 4 column B).

**Figure 3:** Levels from which foundation depths are measured where trees or hedgerows are proposed



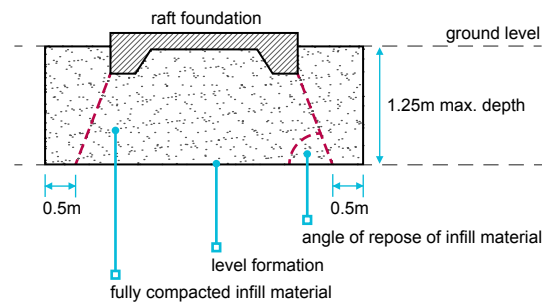
Use the lower of:  
 a) minimum foundation depth (see Table 4 column B)  
 b) foundation depth based on mature height of tree.

**Granular infill beneath raft foundations in shrinkable soils**

Granular infill should be placed beneath raft foundations on shrinkable soils as shown below.

Infill should:

- be at least 50% of the foundation depth and not more than 1.25m deep (measured from ground level determined in accordance with 4.2.9b)
- extend beyond the edge of the foundation by a distance equal to its natural angle of repose, plus 0.5m.



**Steps in foundations**

On sloping ground, foundation trenches can be gradually stepped so that the required foundation depth is reasonably uniform below ground level.

Where foundations are to be stepped to take account of the influence of trees, hedgerows and shrubs, they should be stepped gradually, with no step exceeding 0.5m.

**Heave precautions <sup>4.2.10</sup>**

*Also see: Chapter 2.1 and BS 5837*

**Foundations, substructures and services shall be suitably designed and detailed to prevent excessive movement due to heave. Heave precautions shall be incorporated into foundations and substructures in accordance with the design. Items to be taken into account include:**

- |                                      |                            |
|--------------------------------------|----------------------------|
| a) potential for ground movement     | e) other foundation types  |
| b) minimum void dimensions           | f) suspended ground floors |
| c) proprietary heave materials       | g) paths and driveways.    |
| d) heave precautions for foundations |                            |

Where foundations and substructure may be subject to heave, they should be protected by voids, void formers or compressible materials.

Where proprietary materials are used, the design of foundations and substructure should take into account the upward force transmitted through the compressible material or void former prior to collapse (refer to manufacturer's data).

This section provides guidance on heave precautions for common building elements when located within the influence of trees which are to remain or be removed, including:

- |                             |                          |
|-----------------------------|--------------------------|
| ■ trench fill foundations   | ■ other foundation types |
| ■ pier and beam foundations | ■ paths and driveways    |
| ■ pile and beam foundations | ■ new drainage.          |

### Potential for ground movement

After the felling or removal of trees and hedgerows on shrinkable soils, heave can occur, as the absorbed moisture causes swelling. Heave can also occur beneath a building where:

- roots are severed
- there are changes in ground water conditions.
- water enters the ground from leaking drains and services

### Minimum void dimensions

Voids should be provided to accommodate movement due to heave forces acting against foundations and suspended ground floors in accordance with Table 7.

**Table 7:** Void dimensions

Volume change potential	Void dimension against side of foundation and ground beam	Void dimension under ground beams, and suspended in-situ concrete ground floor	Void dimension under suspended precast concrete and timber floors <sup>(1)</sup>
High	35mm	150mm	300mm
Medium	25mm	100mm	250mm
Low	0mm	50mm	200mm

#### Notes

1 Under suspended floors, the void dimension is measured from the underside of beam or joist to ground level and includes 150mm ventilation allowance.

Void formers consist of materials that collapse to form a void into which the clay can swell. The void dimension is the 'remaining void' after collapse. The thickness of the void former should be in accordance with the manufacturer's recommendations.

### Proprietary materials to accommodate heave

Compressible material compacts as clay expands; the void dimension is the amount the material should be able to compress to accommodate heave. The thickness of compressible material required should be established from the manufacturer's recommendations, but generally will be approximately twice the void dimension shown.

Each material should be assessed in accordance with Technical Requirement R3 and used in accordance with the independent assessment and the manufacturer's recommendations.

The correct placement of heave materials is essential to ensure the foundations and substructure are adequately protected from heave forces.

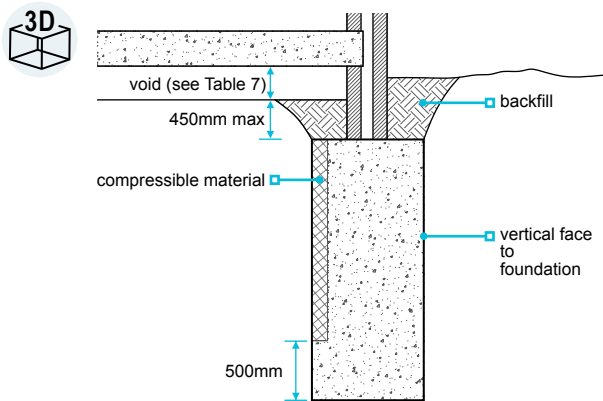
### Heave precautions for foundations

Table 8 shows where heave precautions are required for trench fill, pier and beam, and pile and beam foundation types which are in the zone of influence of trees (see Table 3b) which are to remain or be removed.

**Table 8:** Position of heave precautions

Situation (see figures 4,5 & 6)	Trench fill	Pier and beam	Pile and beam
External trench fill and pier foundations. Unless NHBC is satisfied that the soil is not desiccated compressible material should be provided to the:	Inside faces of external wall foundations deeper than 1.5m, based on the appropriate tree height.	All faces of pier foundations deeper than 1.5m, based on the appropriate tree height.	N/A
External ground beams. Unless NHBC is satisfied that the soil is not desiccated compressible material or void formers should be provided to the:	N/A	Inside faces.	Inside faces.
Internal trench fill foundations and ground beams. Compressible material required:	No	No	No
External and internal ground beams. Compressible material, void former or void should be provided to the underside of:	N/A	All	All
Heave precautions required for proposed trees where the soil is not desiccated:	No	No	No

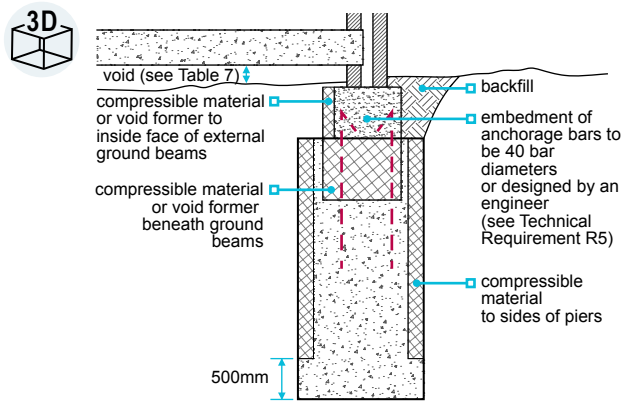
**Figure 4:** Heave precautions for trench fill foundations up to 2.5m deep



It is essential that:

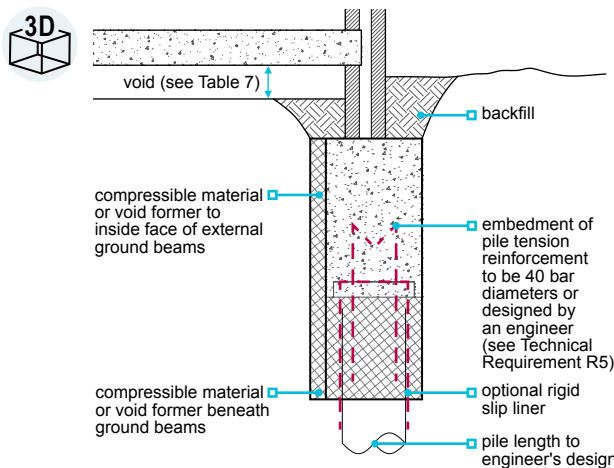
- Compressible material is provided to the entire area shown, and the foundation excavation has a vertical face.
- Where the excavation is battered or if there is overbreak or concrete overspill, it may be necessary to consult an engineer.

**Figure 5:** Heave precautions for pier and beam foundations



It is essential that heave material is provided to the entire areas shown. Particular care should be taken to ensure that the full width of the ground beam is protected.

**Figure 6:** Heave precautions for pile and beam foundations



It is essential that heave material is provided to the entire areas shown. Particular care should be taken to ensure that the full width of the ground beam and the areas around the piles are protected.

Raft foundations constructed in accordance with Clause 4.2.8 and Clause 4.2.9 should provide adequate protection from heave.

### Other foundation types

All foundations not covered in this chapter, but specifically designed to counteract heave, should be:

- designed by an engineer taking account of this guidance
- submitted to NHBC for approval prior to commencing work on site.

### Suspended ground floors

Suspended ground floors with voids in accordance with Table 7 should be used in situations where heave can occur within the area bounded by the foundations, including where:

- foundation depth, determined in accordance with this chapter, is more than 1.5m, unless NHBC is satisfied the soil is not desiccated, or
- ground floor construction is undertaken when the surface soils are seasonally desiccated (i.e. during summer and autumn), unless NHBC is satisfied the soil is not desiccated.

### Paths and driveways

Paths and driveways should be designed and detailed to cater for the likely ground movement.

### New drainage <sup>4.2.11</sup>

Also see: Chapter 5.3

#### Drainage shall be in accordance with the design and allow for ground movement.

To protect against the effects of heave, drainage should be designed:

- to take account of potential ground movement as shown in Table 9, including where pipes and services pass through substructure walls or foundations
- with gradients which may need to be greater than those in Chapter 5.3 'Drainage below ground' as these do not account for possible ground movement
- to use alternative means of catering for the movement when sufficient falls cannot be provided, for example by deepening the excavation and laying the pipework on a granular bedding of suitable thickness to reduce the extent of potential movement.

**Table 9:** Volume change potential

Volume change potential	Potential ground movement (mm)
High	150
Medium	100
Low	50

Note

Existing land drains should be maintained or diverted.

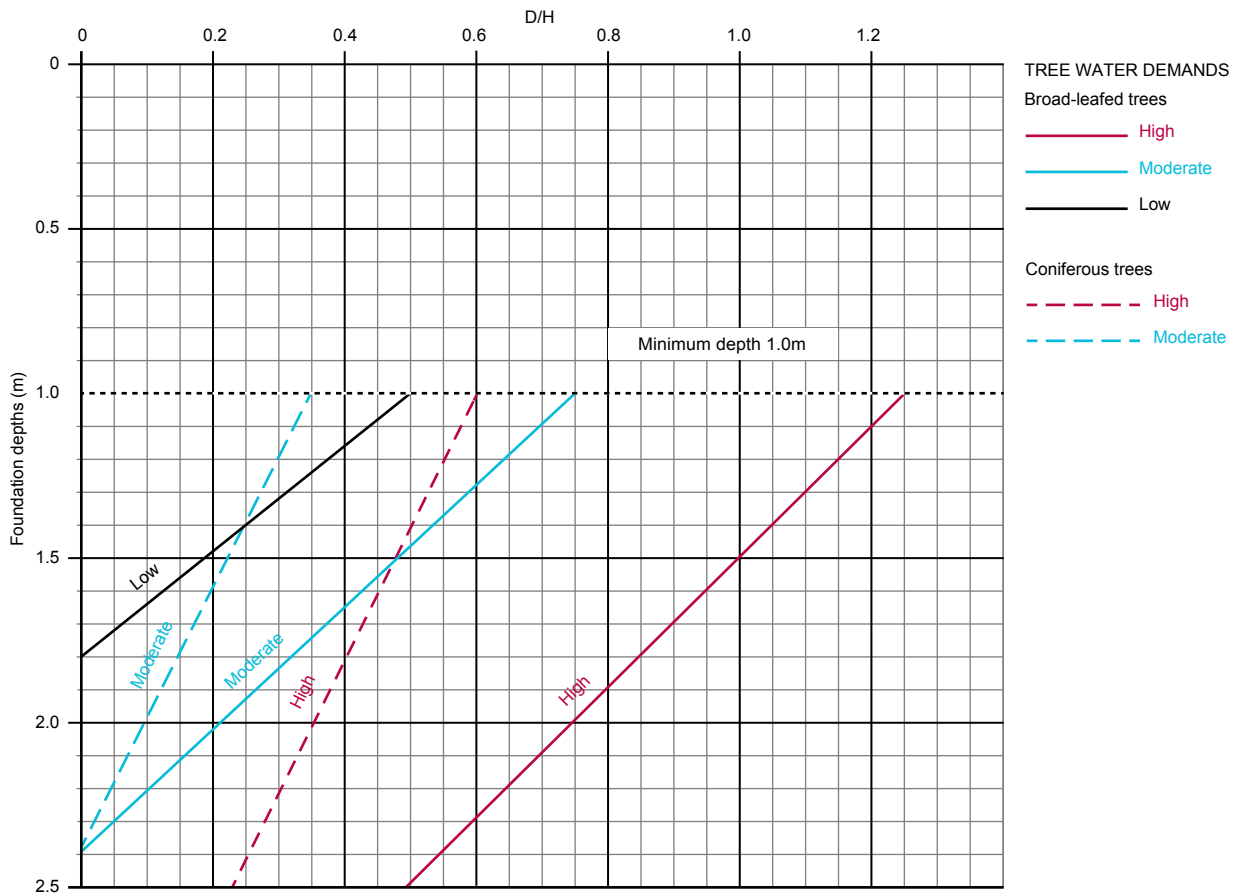
### Foundation depth charts <sup>4.2.12</sup>

**Table 10:** Determination of D/H value

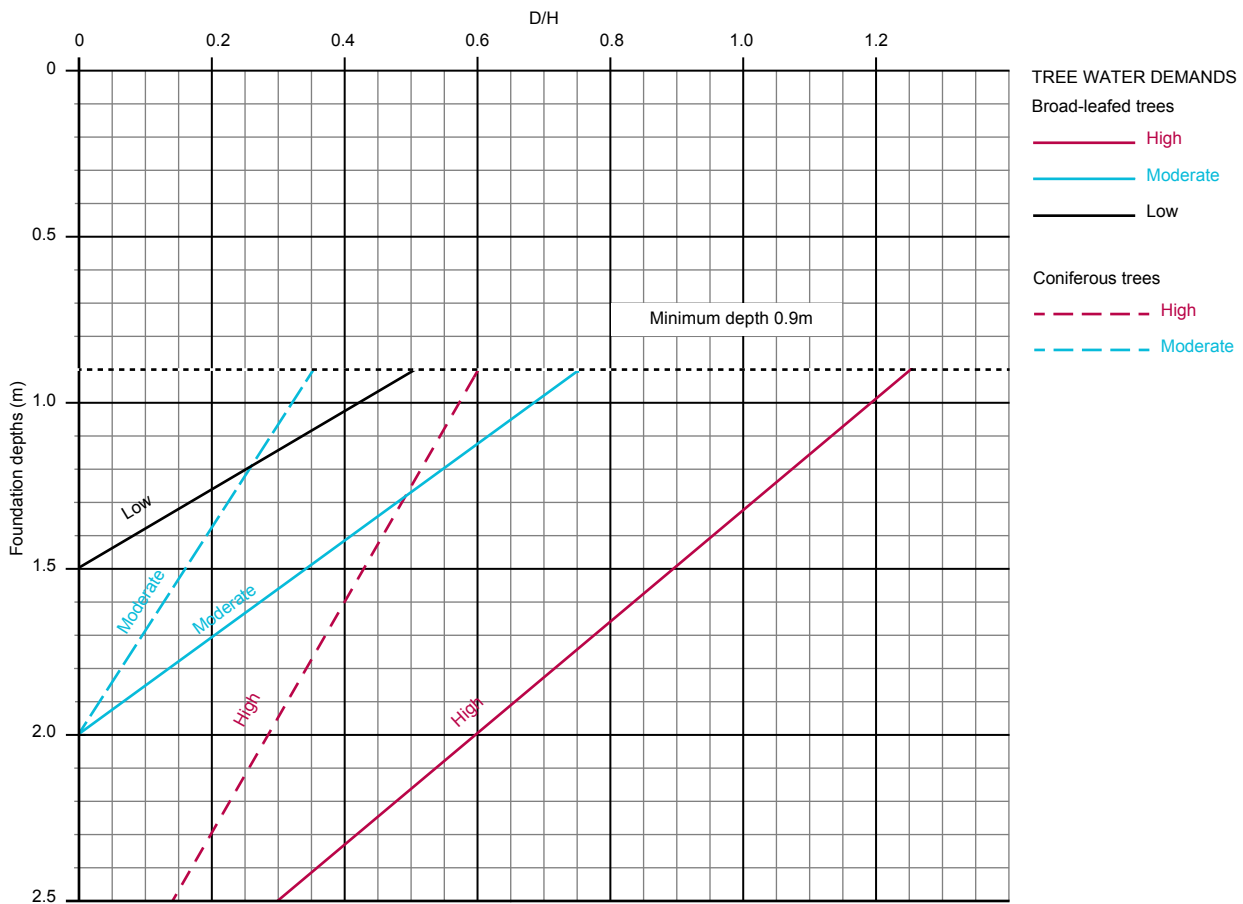
Determination of D/H value															
Distance D (m)	Tree H (m)														
	2	4	6	8	10	12	14	16	18	20	22	24	26	28	30
1	0.50	0.25	0.17	0.13	0.10	0.08	0.07	0.06	0.06	0.05	0.05	0.04	0.04	0.04	0.03
2	1.00	0.50	0.33	0.25	0.20	0.17	0.14	0.13	0.11	0.10	0.09	0.08	0.08	0.07	0.07
3		0.75	0.50	0.38	0.30	0.25	0.21	0.19	0.17	0.15	0.14	0.13	0.12	0.11	0.10
4		1.00	0.67	0.50	0.40	0.33	0.29	0.25	0.22	0.20	0.18	0.17	0.15	0.14	0.13
5			0.83	0.63	0.50	0.42	0.36	0.31	0.28	0.25	0.23	0.21	0.19	0.18	0.17
6			1.00	0.75	0.60	0.50	0.43	0.38	0.33	0.30	0.27	0.25	0.23	0.21	0.20
7			1.17	0.88	0.70	0.58	0.50	0.44	0.39	0.35	0.32	0.29	0.27	0.25	0.23
8				1.00	0.80	0.67	0.57	0.50	0.44	0.40	0.36	0.33	0.31	0.29	0.27
9				1.13	0.90	0.75	0.64	0.56	0.50	0.45	0.41	0.38	0.35	0.32	0.30
10					1.00	0.83	0.71	0.63	0.56	0.50	0.45	0.42	0.38	0.36	0.33
11					1.10	0.92	0.79	0.69	0.61	0.55	0.50	0.46	0.42	0.39	0.37
12					1.20	1.00	0.86	0.75	0.67	0.60	0.55	0.50	0.46	0.43	0.40
13						1.08	0.93	0.81	0.72	0.65	0.59	0.54	0.50	0.46	0.43
14						1.17	1.00	0.88	0.78	0.70	0.64	0.58	0.54	0.50	0.47
15							1.07	0.94	0.83	0.75	0.68	0.63	0.58	0.54	0.50
16							1.14	1.00	0.89	0.80	0.73	0.67	0.62	0.57	0.53
17							1.21	1.06	0.94	0.85	0.77	0.71	0.65	0.61	0.57
18								1.13	1.00	0.90	0.82	0.75	0.69	0.64	0.60
19								1.19	1.06	0.95	0.86	0.79	0.73	0.68	0.63
20									1.11	1.00	0.91	0.83	0.77	0.71	0.67
21									1.17	1.05	0.95	0.88	0.81	0.75	0.70
22										1.10	1.00	0.92	0.85	0.79	0.73
23										1.15	1.05	0.96	0.88	0.82	0.77
24										1.20	1.09	1.00	0.92	0.86	0.80
25											1.14	1.04	0.96	0.89	0.83
26											1.18	1.08	1.00	0.93	0.87
27												1.13	1.04	0.96	0.90
28												1.17	1.08	1.00	0.93
29												1.21	1.12	1.04	0.97
30													1.15	1.07	1.00
31													1.19	1.11	1.03
32														1.14	1.07
33														1.18	1.10
34														1.21	1.13
35															1.17
36															1.20

Where no value is given in the table, minimum foundation depths apply (i.e. 1.0m, 0.9m and 0.75 m for high, medium and low volume change potential soils respectively).

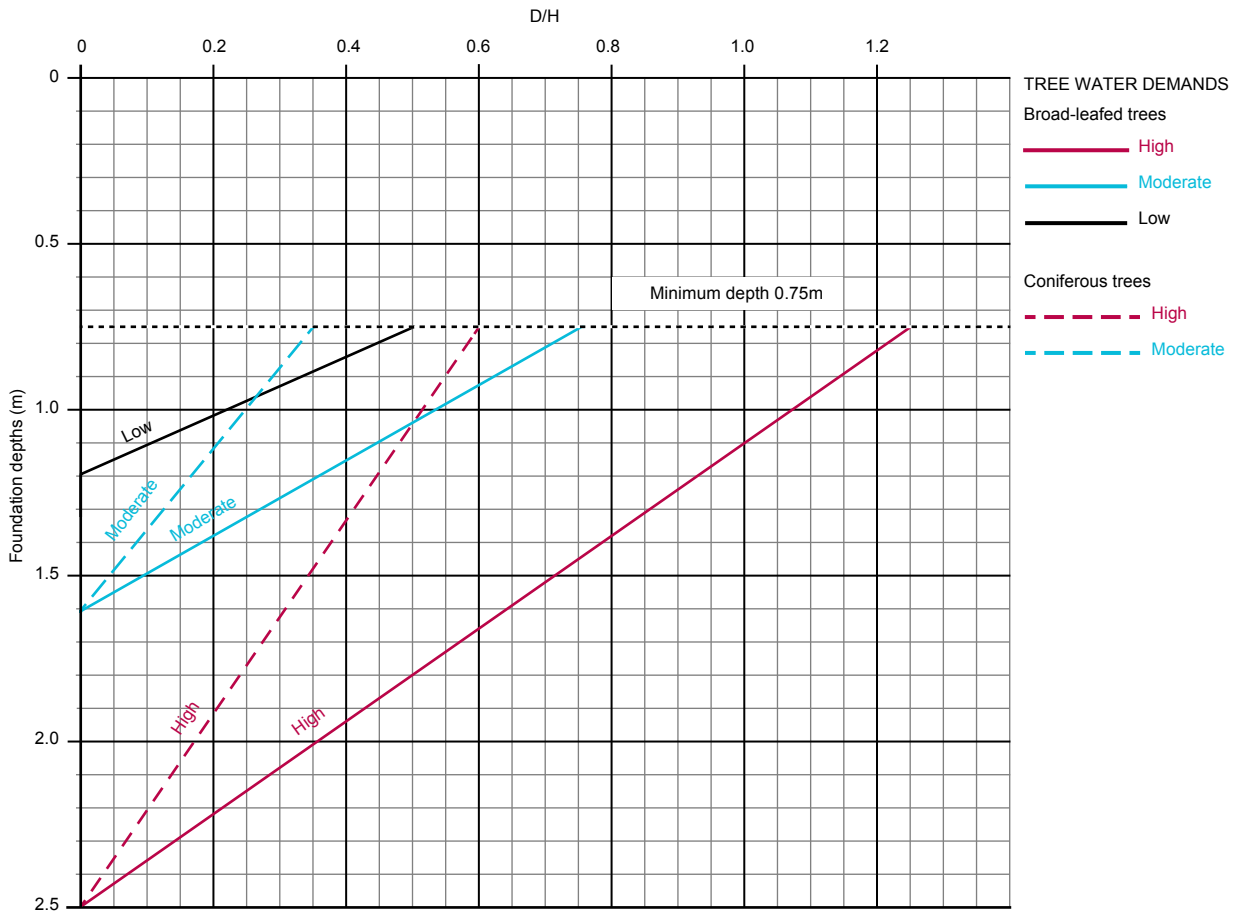
**Chart 1:** Soils with HIGH volume change potential – Modified Plasticity Index 40% or greater



**Chart 2:** Soils with MEDIUM volume change potential – Modified Plasticity Index between 20% and less than 40%



**Chart 3:** Soils with LOW volume change potential – Modified Plasticity Index 10 to less than 20%



4.2

**Foundation depth tables 4.2.13**

**Table 11: HIGH shrinkage soil and HIGH water demand tree**

<b>Broad-leafed trees</b>												
<b>Foundation depth (m)</b>												
<b>Distance D (m)</b>	<b>Tree height H (m)</b>											
	8	10	12	14	16	18	20	22	24	26	28	30
1												
2												
3												
4	2.50											
5	2.25	2.50										
6	2.00	2.30	2.50									
7	1.75	2.10	2.35	2.50								
8	1.50	1.90	2.20	2.40	2.50							
9	1.25	1.70	2.00	2.25	2.40	2.50						
10	1.00	1.50	1.85	2.10	2.25	2.40	2.50					
11	1.00	1.30	1.70	1.95	2.15	2.30	2.40	2.50				
12	1.00	1.10	1.50	1.80	2.00	2.20	2.30	2.45	2.50			
13		1.00	1.35	1.65	1.90	2.10	2.20	2.35	2.45	2.50		
14		1.00	1.20	1.50	1.75	1.95	2.10	2.25	2.35	2.45	2.50	
15			1.00	1.40	1.65	1.85	2.00	2.15	2.25	2.35	2.45	2.50
16			1.00	1.25	1.50	1.75	1.90	2.05	2.20	2.30	2.40	2.45
17			1.00	1.10	1.40	1.65	1.80	1.95	2.10	2.20	2.30	2.40
18			1.00	1.25	1.50	1.70	1.90	2.00	2.15	2.25	2.30	
19			1.00	1.15	1.40	1.60	1.80	1.95	2.05	2.15	2.25	
20			1.00	1.30	1.50	1.70	1.85	2.00	2.10	2.20		
21			1.00	1.20	1.40	1.60	1.75	1.90	2.00	2.10		
22			1.00	1.10	1.30	1.50	1.70	1.85	1.95	2.05		
23			1.00	1.20	1.45	1.60	1.75	1.90	2.00			
24			1.00	1.10	1.35	1.50	1.65	1.80	1.90			
25				1.00	1.25	1.45	1.60	1.75	1.85			
26				1.00	1.15	1.35	1.50	1.65	1.80			
27				1.00	1.05	1.25	1.45	1.60	1.70			
28					1.00	1.20	1.35	1.50	1.65			
29					1.00	1.10	1.30	1.45	1.60			
30						1.00	1.20	1.40	1.50			
31							1.00	1.15	1.30	1.45		
32							1.00	1.05	1.25	1.40		
33								1.00	1.15	1.30		
34								1.00	1.10	1.25		
35									1.00	1.20		
36									1.00	1.10		
37									1.00	1.05		
38										1.00		

<b>Coniferous trees</b>												
<b>Foundation depth (m)</b>												
<b>Distance D (m)</b>	<b>Tree height H (m)</b>											
	8	10	12	14	16	18	20	22	24	26	28	30
1												
2	2.50											
3	1.95	2.25	2.50									
4	1.45	1.85	2.15	2.35	2.50							
5	1.00	1.45	1.80	2.05	2.20	2.35	2.50					
6		1.00	1.45	1.75	1.95	2.15	2.25	2.40	2.50			
7		1.00	1.10	1.45	1.70	1.90	2.05	2.20	2.30	2.40	2.50	
8			1.00	1.15	1.45	1.65	1.85	2.00	2.15	2.25	2.35	2.40
9				1.00	1.20	1.45	1.65	1.80	1.95	2.10	2.20	2.25
10					1.00	1.20	1.45	1.65	1.80	1.90	2.05	2.15
11						1.00	1.25	1.45	1.60	1.75	1.90	2.00
12							1.00	1.25	1.45	1.60	1.75	1.85
13								1.00	1.05	1.25	1.45	1.60
14									1.00	1.10	1.30	1.45
15										1.00	1.10	1.30
16											1.00	1.15
17												1.00
18												1.00
19												1.00
20												1.00
21												1.00
22												1.00
23												1.00
24												1.00
25												1.00
26												1.00
27												1.00
28												1.00
29												1.00
30												1.00
31												1.00
32												1.00
33												1.00
34												1.00
35												1.00
36												1.00
37												1.00
38												1.00

**Table 12:** HIGH Shrinkage soil and MODERATE water demand tree

Broad-leaved trees													Coniferous trees												
Foundation depth (m)													Foundation depth (m)												
Distance Tree height H (m)													Distance Tree height H (m)												
D (m)	8	10	12	14	16	18	20	22	24	26	28	30	D (m)	8	10	12	14	16	18	20	22	24	26	28	30
1	2.20	2.25	2.25	2.30	2.30	2.30	2.35	2.35	2.35	2.35	2.35	2.35	1.90	2.00	2.10	2.15	2.15	2.20	2.20	2.25	2.25	2.25	2.30	2.30	
2	1.95	2.05	2.10	2.15	2.20	2.20	2.25	2.25	2.25	2.30	2.30	2.30	1.40	1.60	1.75	1.85	1.90	2.00	2.00	2.05	2.10	2.10	2.15	2.15	
3	1.70	1.85	1.95	2.00	2.05	2.10	2.15	2.15	2.20	2.20	2.20	2.25	1.00	1.20	1.40	1.55	1.65	1.75	1.80	1.85	1.90	1.95	2.00	2.00	
4	1.50	1.65	1.80	1.90	1.95	2.00	2.05	2.10	2.10	2.15	2.15	2.15		1.00	1.10	1.30	1.40	1.55	1.60	1.70	1.75	1.80	1.85	1.90	
5	1.25	1.50	1.65	1.75	1.85	1.90	1.95	2.00	2.05	2.05	2.10	2.10			1.00	1.00	1.15	1.30	1.40	1.50	1.60	1.65	1.70	1.75	
6	1.00	1.30	1.50	1.60	1.70	1.80	1.85	1.90	1.95	2.00	2.00	2.05				1.00	1.10	1.20	1.35	1.40	1.50	1.55	1.60	1.60	
7	1.00	1.10	1.35	1.50	1.60	1.70	1.75	1.85	1.90	1.90	1.95	2.00					1.00	1.00	1.15	1.25	1.35	1.40	1.50	1.50	
8		1.00	1.20	1.35	1.50	1.60	1.65	1.75	1.80	1.85	1.90	1.90						1.00	1.00	1.15	1.25	1.35	1.40	1.50	
9			1.00	1.20	1.35	1.50	1.60	1.65	1.70	1.75	1.80	1.85							1.00	1.00	1.15	1.25	1.35	1.40	
10				1.00	1.10	1.25	1.40	1.50	1.55	1.65	1.70	1.75	1.80								1.00	1.00	1.10	1.20	1.30
11					1.00	1.15	1.30	1.40	1.50	1.55	1.65	1.70	1.75									1.00	1.00	1.10	1.20
12						1.00	1.20	1.30	1.40	1.50	1.55	1.60	1.65										1.00	1.10	1.20
13							1.00	1.05	1.20	1.30	1.40	1.50	1.55	1.60										1.00	1.10
14								1.00	1.10	1.25	1.35	1.40	1.50	1.55											1.00
15									1.00	1.15	1.25	1.35	1.40	1.50											1.00
16										1.00	1.05	1.20	1.25	1.35	1.40										1.00
17											1.00	1.10	1.20	1.30	1.35										1.00
18												1.00	1.15	1.20	1.30										1.00
19													1.00	1.05	1.15	1.25									1.00
20														1.00	1.10	1.20									1.00
21																1.00	1.10								1.00
22																		1.00	1.05						1.00
23																									1.00

**Table 13:** HIGH shrinkage soil and LOW water demand tree

Broad-leaved trees												
Foundation depth (m)												
Distance Tree height H (m)												
D (m)	8	10	12	14	16	18	20	22	24	26	28	30
1	1.60	1.65	1.70	1.70	1.70	1.75	1.75	1.75	1.75	1.75	1.75	1.75
2	1.40	1.50	1.55	1.60	1.60	1.65	1.65	1.65	1.65	1.70	1.70	1.70
3	1.20	1.35	1.40	1.50	1.50	1.55	1.60	1.60	1.60	1.65	1.65	1.65
4	1.00	1.20	1.30	1.35	1.40	1.45	1.50	1.55	1.55	1.55	1.60	1.60
5		1.00	1.15	1.25	1.30	1.40	1.40	1.45	1.50	1.50	1.55	1.55
6			1.00	1.15	1.20	1.30	1.35	1.40	1.40	1.45	1.50	1.50
7				1.00	1.10	1.20	1.25	1.30	1.35	1.40	1.40	1.45
8					1.00	1.10	1.20	1.25	1.30	1.35	1.35	1.40
9						1.00	1.10	1.15	1.20	1.25	1.30	1.35
10							1.00	1.10	1.15	1.20	1.25	1.30
11								1.00	1.10	1.15	1.20	1.25
12									1.00	1.10	1.15	1.20
13										1.00	1.10	1.15
14											1.00	1.05
15												1.00



**Table 14: MEDIUM shrinkage soil and HIGH water demand tree**

Broad-leafed trees															
Foundation depth (m)															
Distance D (m)	Tree height H (m)														
	8	10	12	14	16	18	20	22	24	26	28	30			
1															
2															
3	2.40	2.50													
4	2.20	2.35	2.45												
5	1.95	2.20	2.30	2.40	2.50										
6	1.75	2.00	2.20	2.30	2.40	2.45	2.50								
7	1.55	1.85	2.05	2.20	2.30	2.35	2.45	2.50							
8	1.35	1.70	1.90	2.05	2.20	2.25	2.35	2.40	2.45	2.50					
9	1.15	1.50	1.75	1.95	2.10	2.20	2.25	2.35	2.40	2.45	2.50	2.50			
10	0.90	1.35	1.60	1.80	1.95	2.10	2.20	2.25	2.30	2.35	2.40	2.45			
11	0.90	1.15	1.50	1.70	1.85	2.00	2.10	2.20	2.25	2.30	2.35	2.40			
12	0.90	1.00	1.35	1.60	1.75	1.90	2.00	2.10	2.20	2.25	2.30	2.35			
13		0.90	1.20	1.45	1.65	1.80	1.95	2.05	2.10	2.20	2.25	2.30			
14		0.90	1.05	1.35	1.55	1.70	1.85	1.95	2.05	2.10	2.20	2.25			
15			0.90	1.20	1.45	1.60	1.75	1.85	1.95	2.05	2.10	2.20			
16			0.90	1.10	1.35	1.55	1.70	1.80	1.90	2.00	2.05	2.10			
17			0.90	1.00	1.25	1.45	1.60	1.70	1.85	1.90	2.00	2.05			
18				0.90	1.15	1.35	1.50	1.65	1.75	1.85	1.95	2.00			
19				0.90	1.05	1.25	1.40	1.55	1.70	1.80	1.90	1.95			
20					0.90	1.15	1.35	1.50	1.60	1.75	1.80	1.90			
21					0.90	1.05	1.25	1.40	1.55	1.65	1.75	1.85			
22					0.90	0.95	1.15	1.35	1.50	1.60	1.70	1.80			
23						0.90	1.10	1.25	1.40	1.55	1.65	1.75			
24						0.90	1.00	1.20	1.35	1.45	1.60	1.70			
25							0.90	1.10	1.25	1.40	1.50	1.60			
26							0.90	1.05	1.20	1.35	1.45	1.55			
27							0.90	0.95	1.15	1.30	1.40	1.50			
28								0.90	1.05	1.20	1.35	1.45			
29								0.90	1.00	1.15	1.30	1.40			
30									0.90	1.10	1.20	1.35			
31									0.90	1.00	1.15	1.30			
32										0.90	0.95	1.10	1.25		
33											0.90	1.05	1.15		
34											0.90	1.00	1.10		
35												0.90	1.05		
36													0.90	1.00	
37														0.90	0.95
38															0.90

Coniferous trees														
Foundation depth (m)														
Distance D (m)	Tree height H (m)													
	8	10	12	14	16	18	20	22	24	26	28	30		
1														
2	2.15	2.30	2.45	2.50										
3	1.70	1.95	2.15	2.25	2.35	2.45	2.50							
4	1.25	1.60	1.85	2.00	2.15	2.25	2.30	2.40	2.45	2.50	2.50			
5	0.90	1.25	1.55	1.75	1.95	2.05	2.15	2.20	2.30	2.35	2.40	2.45		
6		0.90	1.25	1.50	1.70	1.85	1.95	2.05	2.15	2.20	2.25	2.30		
7			0.90	1.25	1.50	1.65	1.80	1.90	2.00	2.10	2.15	2.20		
8				0.90	1.00	1.25	1.45	1.60	1.75	1.85	1.95	2.00	2.10	
9					0.90	1.05	1.25	1.45	1.60	1.70	1.80	1.90	1.95	
10						0.90	1.10	1.25	1.45	1.55	1.65	1.75	1.85	
11							0.90	1.10	1.25	1.40	1.55	1.65	1.75	
12								0.90	1.10	1.25	1.40	1.50	1.60	
13									0.90	0.95	1.10	1.25	1.40	1.50
14										0.90	1.00	1.15	1.25	1.40
15											0.90	1.00	1.15	1.25
16												0.90	1.00	1.15
17													0.90	1.05
18														0.90
19														
20														
21														
22														
23														
24														
25														
26														
27														
28														
29														
30														
31														
32														
33														
34														
35														
36														
37														
38														

4.2

**Table 15:** MEDIUM shrinkage soil and MODERATE water demand tree

Broad-leafed trees													Coniferous												
Foundation depth (m)													Foundation depth (m)												
Distance D (m)	Tree height H (m)												Distance D (m)	Tree height H (m)											
	8	10	12	14	16	18	20	22	24	26	28	30		8	10	12	14	16	18	20	22	24	26	28	30
1	1.85	1.85	1.90	1.90	1.95	1.95	1.95	1.95	1.95	1.95	1.95	1.95	1.65	1.70	1.75	1.80	1.80	1.85	1.85	1.90	1.90	1.90	1.90	1.90	
2	1.65	1.75	1.80	1.80	1.85	1.85	1.85	1.90	1.90	1.90	1.90	1.90	1.25	1.40	1.50	1.55	1.65	1.65	1.70	1.75	1.75	1.80	1.80	1.80	
3	1.45	1.60	1.65	1.70	1.75	1.80	1.80	1.80	1.85	1.85	1.85	1.85	0.90	1.10	1.25	1.35	1.45	1.50	1.55	1.60	1.65	1.65	1.70	1.70	
4	1.30	1.45	1.55	1.60	1.65	1.70	1.75	1.75	1.80	1.80	1.80	1.80		0.90	0.95	1.10	1.25	1.30	1.40	1.45	1.50	1.55	1.55	1.60	
5	1.10	1.30	1.40	1.50	1.55	1.60	1.65	1.70	1.70	1.75	1.75	1.80			0.90	0.90	1.05	1.15	1.25	1.30	1.35	1.40	1.45	1.50	
6	0.90	1.15	1.30	1.40	1.45	1.55	1.60	1.60	1.65	1.70	1.70	1.75				0.90	0.95	1.10	1.15	1.25	1.30	1.35	1.40	1.40	
7	0.90	1.00	1.15	1.30	1.40	1.45	1.50	1.55	1.60	1.65	1.65	1.70					0.90	0.90	1.00	1.10	1.15	1.25	1.30	1.30	
8		0.90	0.05	1.20	1.30	1.35	1.45	1.50	1.55	1.55	1.60	1.65						0.90	0.95	1.05	1.10	1.15	1.25	1.30	
9			0.90	1.10	1.20	1.30	1.35	1.40	1.45	1.50	1.55	1.60							0.90	0.95	1.00	1.10	1.15	1.20	
10				0.90	0.95	1.10	1.20	1.30	1.35	1.40	1.45	1.50								0.90	0.95	1.00	1.10	1.10	
11					0.90	1.00	1.10	1.20	1.30	1.35	1.40	1.45									0.90	0.90	0.95	1.00	0.95
12						0.90	1.05	1.15	1.20	1.30	1.35	1.40													
13							0.90	0.95	1.05	1.15	1.25	1.30													
14								0.90	1.00	1.10	1.15	1.25	1.30												
15									0.90	1.00	1.10	1.15	1.25	1.30											
16										0.90	0.95	1.05	1.10	1.20	1.25										
17											0.90	1.00	1.10	1.15	1.20										
18												0.90	1.00	1.10	1.15										
19													0.90	0.95	1.00	1.10									
20																0.90	0.95	1.05							
21																							0.90	1.00	
22																								0.90	0.95
23																									0.90

**Table 16:** MEDIUM shrinkage soil and LOW water demand tree

Broad-leafed trees												
Foundation depth (m)												
Distance D (m)	Tree height H (m)											
	8	10	12	14	16	18	20	22	24	26	28	30
1	1.35	1.40	1.40	1.45	1.45	1.45	1.45	1.45	1.45	1.45	1.50	1.50
2	1.20	1.30	1.30	1.35	1.35	1.40	1.40	1.40	1.40	1.45	1.45	1.45
3	1.05	1.15	1.20	1.25	1.30	1.30	1.35	1.35	1.35	1.40	1.40	1.40
4	0.90	1.05	1.10	1.20	1.20	1.25	1.30	1.30	1.30	1.35	1.35	1.35
5		0.90	1.00	1.10	1.15	1.20	1.20	1.25	1.25	1.30	1.30	1.30
6			0.90	1.00	1.05	1.10	1.15	1.20	1.20	1.25	1.25	1.30
7				0.90	1.00	1.05	1.10	1.15	1.15	1.20	1.20	1.25
8					0.90	1.00	1.05	1.10	1.10	1.15	1.20	1.20
9						0.90	1.00	1.05	1.05	1.10	1.15	1.15
10							0.90	0.95	1.00	1.05	1.10	1.10
11								0.90	0.95	1.00	1.05	1.10
12									0.90	0.95	1.00	1.05
13										0.90	0.95	1.00
14											0.90	0.95
15												0.90

**Table 17:** LOW shrinkage soil and HIGH water demand tree

Broad-leafed trees												
Foundation depth (m)												
Distance D (m)	Tree height H (m)											
	8	10	12	14	16	18	20	22	24	26	28	30
1	2.35	2.40	2.40	2.40	2.45	2.45	2.45	2.45	2.45	2.45	2.45	2.45
2	2.15	2.25	2.30	2.30	2.35	2.35	2.40	2.40	2.40	2.40	2.40	2.45
3	2.00	2.10	2.15	2.20	2.25	2.30	2.30	2.35	2.35	2.35	2.35	2.40
4	1.80	1.95	2.05	2.10	2.15	2.20	2.25	2.25	2.30	2.30	2.30	2.35
5	1.65	1.80	1.95	2.00	2.10	2.15	2.15	2.20	2.25	2.25	2.25	2.30
6	1.45	1.70	1.80	1.90	2.00	2.05	2.10	2.15	2.20	2.20	2.20	2.25
7	1.30	1.55	1.70	1.80	1.90	2.00	2.05	2.05	2.10	2.15	2.15	2.20
8	1.10	1.40	1.60	1.70	1.80	1.90	1.95	2.00	2.05	2.10	2.10	2.15
9	0.95	1.25	1.45	1.60	1.75	1.80	1.90	1.95	2.00	2.05	2.05	2.10
10	0.75	1.10	1.35	1.50	1.65	1.75	1.80	1.90	1.95	2.00	2.00	2.05
11	0.75	1.00	1.20	1.40	1.55	1.65	1.75	1.80	1.90	1.95	1.95	2.00
12	0.75	0.85	1.10	1.30	1.45	1.60	1.70	1.75	1.80	1.85	1.90	1.95
13		0.75	1.00	1.20	1.40	1.50	1.60	1.70	1.75	1.80	1.85	1.90
14		0.75	0.90	1.10	1.30	1.45	1.55	1.65	1.70	1.75	1.80	1.85
15			0.75	1.00	1.20	1.35	1.45	1.55	1.65	1.70	1.75	1.80
16			0.75	0.90	1.10	1.30	1.40	1.50	1.60	1.65	1.70	1.75
17			0.75	0.80	1.05	1.20	1.35	1.45	1.55	1.60	1.65	1.75
18				0.75	0.95	1.10	1.25	1.35	1.45	1.55	1.60	1.70
19				0.75	0.85	1.05	1.20	1.30	1.40	1.50	1.55	1.65
20					0.75	0.95	1.10	1.25	1.35	1.45	1.50	1.60
21					0.75	0.90	1.05	1.20	1.30	1.40	1.45	1.55
22					0.75	0.80	1.00	1.10	1.25	1.35	1.40	1.50
23						0.75	0.90	1.05	1.20	1.30	1.35	1.45
24						0.75	0.85	1.00	1.10	1.25	1.30	1.40
25							0.75	0.95	1.05	1.15	1.25	1.35
26							0.75	0.85	1.00	1.10	1.20	1.30
27							0.75	0.80	0.95	1.05	1.15	1.25
28								0.75	0.90	1.00	1.10	1.20
29								0.75	0.85	0.95	1.05	1.15
30									0.75	0.90	1.00	1.10
31									0.75	0.85	0.95	1.05
32									0.75	0.80	0.90	1.05
33										0.75	0.85	1.00
34										0.75	0.80	0.95
35											0.75	0.90
36											0.75	0.85
37											0.75	0.80
38												0.75

Coniferous												
Foundation depth (m)												
Distance D (m)	Tree height H (m)											
	8	10	12	14	16	18	20	22	24	26	28	30
1	2.15	2.25	2.30	2.30	2.35	2.35	2.35	2.40	2.40	2.40	2.40	2.40
2	1.80	1.95	2.05	2.10	2.15	2.20	2.25	2.25	2.30	2.30	2.30	2.35
3	1.45	1.65	1.80	1.90	1.95	2.05	2.10	2.10	2.15	2.20	2.20	2.25
4	1.05	1.35	1.55	1.70	1.80	1.85	1.95	2.00	2.05	2.05	2.10	2.15
5	0.75	1.05	1.30	1.50	1.60	1.70	1.80	1.85	1.90	1.95	2.00	2.05
6		0.75	1.05	1.25	1.45	1.55	1.65	1.70	1.80	1.85	1.90	1.95
7			0.75	0.80	1.05	1.25	1.40	1.50	1.60	1.65	1.75	1.80
8				0.75	0.85	1.05	1.20	1.35	1.45	1.55	1.60	1.70
9					0.75	0.90	1.05	1.20	1.35	1.45	1.50	1.60
10						0.75	0.90	1.05	1.20	1.30	1.40	1.50
11							0.75	0.90	1.05	1.20	1.30	1.35
12								0.75	0.95	1.05	1.15	1.25
13									0.75	0.80	0.95	1.05
14										0.75	0.80	0.95
15											0.75	0.85
16												0.75
17												0.75
18												0.75
19												0.75
20												0.75
21												0.75
22												0.75
23												0.75
24												0.75
25												0.75
26												0.75
27												0.75
28												0.75
29												0.75
30												0.75
31												0.75
32												0.75
33												0.75
34												0.75
35												0.75
36												0.75
37												0.75
38												0.75

**Table 18:** LOW shrinkage soil and MODERATE water demand tree

Broad-leafed trees												
Foundation depth (m)												
Distance	Tree height H (m)											
D (m)	8	10	12	14	16	18	20	22	24	26	28	30
1	1.50	1.50	1.55	1.55	1.55	1.55	1.55	1.55	1.55	1.60	1.60	1.60
2	1.35	1.40	1.45	1.45	1.50	1.50	1.50	1.55	1.55	1.55	1.55	1.55
3	1.20	1.30	1.35	1.40	1.40	1.45	1.45	1.45	1.50	1.50	1.50	1.50
4	1.05	1.15	1.25	1.30	1.35	1.35	1.40	1.40	1.45	1.45	1.45	1.45
5	0.90	1.05	1.15	1.20	1.25	1.30	1.35	1.35	1.40	1.40	1.40	1.45
6	0.75	0.95	1.05	1.15	1.20	1.25	1.30	1.30	1.35	1.35	1.40	1.40
7	0.75	0.85	0.95	1.05	1.10	1.20	1.20	1.25	1.30	1.30	1.35	1.35
8		0.75	0.85	0.95	1.05	1.10	1.15	1.20	1.25	1.25	1.30	1.30
9			0.75	0.90	1.00	1.05	1.10	1.15	1.20	1.25	1.25	1.30
10				0.75	0.80	0.90	1.00	1.05	1.10	1.15	1.20	1.25
11					0.75	0.85	0.95	1.00	1.05	1.10	1.15	1.20
12						0.75	0.85	0.95	1.00	1.05	1.10	1.15
13							0.75	0.80	0.90	0.95	1.00	1.10
14								0.75	0.85	0.90	0.95	1.00
15									0.75	0.85	0.90	1.00
16										0.75	0.80	0.85
17											0.75	0.80
18												0.75
19												
20												
21												
22												
23												

Coniferous												
Foundation depth (m)												
Distance	Tree height H (m)											
D (m)	8	10	12	14	16	18	20	22	24	26	28	30
1	1.30	1.40	1.40	1.45	1.45	1.50	1.50	1.50	1.50	1.55	1.55	1.55
2	1.00	1.15	1.20	1.25	1.30	1.35	1.40	1.40	1.40	1.45	1.45	1.45
3	0.75	0.90	1.00	1.10	1.15	1.20	1.25	1.30	1.30	1.35	1.35	1.40
4		0.75	0.80	0.95	1.00	1.10	1.15	1.20	1.20	1.25	1.25	1.30
5			0.75	0.75	0.85	0.95	1.00	1.05	1.10	1.15	1.20	1.20
6					0.75	0.80	0.90	0.95	1.00	1.05	1.10	1.15
7						0.75	0.75	0.85	0.90	0.95	1.00	1.05
8								0.75	0.80	0.85	0.95	0.95
9									0.75	0.80	0.85	0.90
10										0.75	0.75	0.80
11												0.75
12												
13												
14												
15												
16												
17												
18												
19												
20												
21												
22												
23												

**Table 19:** LOW shrinkage soil and LOW water demand tree

Broad-leafed trees												
Foundation depth (m)												
Distance	Tree height H (m)											
D (m)	8	10	12	14	16	18	20	22	24	26	28	30
1	1.10	1.15	1.15	1.15	1.15	1.15	1.20	1.20	1.20	1.20	1.20	1.20
2	1.00	1.05	1.05	1.10	1.10	1.10	1.15	1.15	1.15	1.15	1.15	1.15
3	0.90	0.95	1.00	1.05	1.05	1.05	1.10	1.10	1.10	1.10	1.10	1.15
4	0.75	0.85	0.90	0.95	1.00	1.00	1.05	1.05	1.10	1.10	1.10	1.10
5		0.75	0.85	0.90	0.95	0.95	1.00	1.00	1.05	1.05	1.05	1.05
6			0.75	0.85	0.90	0.90	0.95	0.95	1.00	1.00	1.05	1.05
7				0.75	0.85	0.85	0.90	0.95	0.95	1.00	1.00	1.00
8					0.75	0.80	0.85	0.90	0.90	0.95	0.95	1.00
9						0.75	0.80	0.85	0.90	0.90	0.95	0.95
10							0.75	0.80	0.85	0.85	0.90	0.90
11								0.75	0.80	0.85	0.85	0.90
12									0.75	0.80	0.85	0.85
13										0.75	0.80	0.85
14											0.75	0.80
15												0.75

**Example 4.2.14**

The following is an example of how to determine foundation depths using the information in this chapter. The process may be repeated to allow the foundation to be stepped as its distance from the tree increases.

**Step 1**

Determine the volume change potential of the soil. Ensure the site investigation includes representative sampling and testing.

Site at Oxford, building near a Lombardy poplar (to be retained) and a sycamore (to be removed).

From laboratory tests:

Plasticity Index,  $I_p = 36\%$

Test results also report that 100% of particles are smaller than  $425\mu\text{m}$ .

Therefore:

$$\text{Modified Plasticity Index, } I'_p = \frac{36 \times 100}{100} = 36\%$$

Volume change potential = medium

(In the absence of tests, assume high volume change potential.)

This example is typical of Oxford clay. More than 35% of the particles are smaller than  $60\mu\text{m}$  and therefore the soil is shrinkable. 100% of the particles are smaller than  $425\mu\text{m}$  and therefore  $I'_p$  is the same as the  $I_p$ .

A typical boulder clay also has more than 35% of particles smaller than  $60\mu\text{m}$  and is therefore also shrinkable. However, it may have only 80% of its particles smaller than  $425\mu\text{m}$ , in which case, the  $I'_p$  is 80% of the  $I_p$ .

A typical clayey sand may have less than 30% of its particles smaller than  $60\mu\text{m}$ , in which case, the soil would be non-shrinkable.

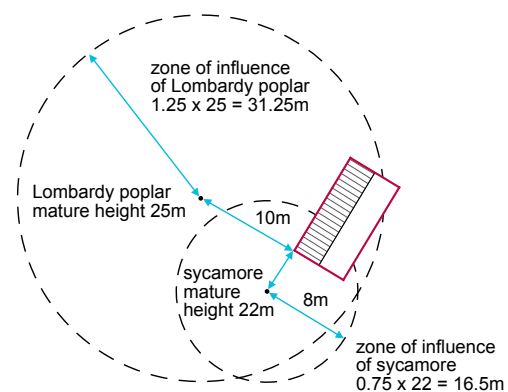
**Step 2**

Establish the species, mature height and water demand of all trees and hedgerows within the influencing radii.

Lombardy poplar	Sycamore
Mature height = 25m Water demand = high	Mature height = 22m Water demand = moderate

**Step 3**

Plot the trees and hedgerows relative to the foundations and draw their zones of influence to determine which trees will affect the foundation design. Use a scaled plan.



### Step 4

Establish the appropriate tree height H to use.

Always use the mature height for remaining and proposed trees and hedgerows. The appropriate height to use for removed trees and hedgerows depends on the actual height when they are removed.

Lombardy poplar	Sycamore
Tree to remain. Therefore: H = mature height = 25m	Tree to be removed Mature height = 22m Actual height = 15m Actual height greater than 50% mature height. Therefore: H = mature height = 22m

### Step 5

Measure the distance D from the centre of the trees or hedgerows to the face of the foundation.

Lombardy poplar	Sycamore
Distance D = 10m from foundation	Distance D = 8m from foundation

### Step 6

Either:

- use the NHBC Foundation Depth Calculator App, or
- select steps 6C (a) and (b) if using charts in Clause 4.2.12 to derive depths, or
- select step 6T if using tables in Clause 4.2.13.

#### Step 6C (a)

Calculate D/H value

Distance D from face of foundation (step 5) divided by the appropriate tree height H (Step 4).  
Alternatively D/H can be obtained from Clause 4.2.12.

Lombardy poplar	Sycamore
D = 10 = D/H = 0.4 H = 25	D = 8 = D/H = 0.36 H = 22

#### Step 6C (b)

Determine foundation depth using the charts in Clause 4.2.12 as follows:

Volume change potential	Chart number
High	1
Medium	2
Low	3

Lombardy poplar	Sycamore
In this example, the volume change potential is medium, then from Chart 2 for broad-leafed high water demand trees at D = 0.4 H Foundation depth = 2.33m	In this example, the volume change potential is medium, then from Chart 2 for broad-leafed moderate water demand trees at D = 0.36 H Foundation depth = 1.50m

The Lombardy poplar is the tree requiring the greater depth (2.33m).

**Step 6T**

Determine foundation depth using the tables in 4.2.13 as follows:

Volume change potential	Tree water demand	Table number
High	High	11
	Moderate	12
	Low	13
Medium	High	14
	Moderate	15
	Low	16
Low	High	17
	Moderate	18
	Low	19

**Step 7**

Adjust the depth according to the climatic zone.

A reduction may be made for distance north and west of London, but the final depth should not be less than the minimum given in each chart and table.

Oxford is between 50 and 100 miles NW of London. From 4.2.5, a reduction of 0.05m is permitted.

Final foundation depth = 2.33 – 0.05 = 2.28m

**Further information 4.2.15**

- BRE Digests 40, 241 and 242 'Low rise buildings on shrinkable clay soils', parts 1, 2 and 3
- BRE Digest 298 'The influence of trees on house foundations in clay soils'
- BRE Digest 412 'Desiccation in clay soils'
- BS 1377 'Methods of test for soils for civil engineering purposes'
- BS 5930 'Code of practice for site investigations'
- Tree Recognition – A Pocket Manual by Ian Richardson and Rowena Gale, Richardson's Botanical Identifications, 49/51 Whiteknights Road, Reading, Berks RG6 7BB
- Field Guide to the Trees of Britain and Northern Europe by Alan Mitchell, Harper Collins
- Glasgow geological survey maps obtainable from British Geological Survey, Nicker Hill, Keyworth, Nottingham NG12 5GG; Tel: 0115 936 3100
- Tree root damage to buildings Vol.1 Causes, Diagnosis and Remedy, Vol. 2 Patterns of Soil Drying in Proximity to Trees on Clay Soils by P G Biddle, Willowmead Publishing, Wantage OX12 9JA
- Institution of Civil Engineers  
1-7 Great George Street, London SW1P 3AA;  
Tel: 020 7222 7722; [www.ice.org.uk](http://www.ice.org.uk)
- Institution of Structural Engineers  
11 Upper Belgrave Street, London SW1X 8BH;  
Tel: 020 7235 4535

Acknowledgements: NHBC gratefully acknowledges the help given by authoritative organisations and individuals in the preparation of this chapter, particularly: Building Research Establishment; Dr P G Biddle, arboricultural consultant.

# Strip and trench fill foundations

## CHAPTER 4.3

This chapter gives guidance on meeting the Technical Requirements for strip and trench fill foundations.

4.3.1	Compliance	01
4.3.2	Provision of information	01
4.3.3	Ground conditions	01
4.3.4	Hazardous ground	02
4.3.5	Setting out	02
4.3.6	Services and drainage	03
4.3.7	Safe transmission of loads	03
4.3.8	Sloping ground and stepped foundations	05
4.3.9	Excavations	05
4.3.10	Reinforcement	06
4.3.11	Concrete	06
4.3.12	Movement joints	06
4.3.13	Construction joints	06



Raising Standards. Protecting Homeowners



### Compliance <sup>4.3.1</sup>

*Also see: Chapter 2.1*

**Strip and trench fill foundations shall comply with the Technical Requirements and provide adequate support to all load-bearing elements.**

Strip and trench fill foundations that comply with the guidance in this chapter will generally be acceptable.

Foundations should be designed by an engineer in accordance with Technical Requirement R5 where:

- buildings exceed three storeys in height
- supporting/retaining walls form habitable rooms below ground
- trench fill foundations are deeper than 2.5m
- they will be deeper than those of an adjoining construction.

Elements of the building requiring foundations include:

- external walls
- separating (party) walls
- internal load-bearing walls
- chimney breasts
- piers.

In Scotland, a sleeper wall is defined as a load-bearing element and therefore should be provided with a suitable foundation.

In England, Wales, Northern Ireland and the Isle of Man, sleeper walls should be provided with suitable foundations where the oversite concrete is:

- cast on shrinkable clay soils where heave could take place
- less than 100mm thick.
- cast on infill deeper than 600mm

### Provision of information <sup>4.3.2</sup>

*Also see: Chapter 4.1*

**Designs and specifications shall be produced in a clearly understandable format, include all relevant information and be distributed to all appropriate personnel.**

Clear and fully detailed drawings should be available on site to enable work to be carried out in accordance with the design. Design and specification information should be issued to site supervisors, relevant specialist subcontractors and/or suppliers. All necessary dimensions and levels should be indicated and relate to at least one benchmark and reference points on the site.

Information on ground conditions, the site investigation and the foundation design may be requested by NHBC, including sites which may not be classified as hazardous.

Both designers and site operatives need to be aware of the ground conditions and any features requiring special attention, such as existing sewers or other services, the water table and the presence of any hazardous substances, including sulfates.

Where toxic materials or those likely to present a health hazard are found, all available information should be supplied to NHBC, together with proposals for remediation.

Full details of junctions, steps, movement joints and any critical sequences of construction should be provided.

### Ground conditions <sup>4.3.3</sup>

*Also see: Chapters 3.2, 4.1, 4.2 and 5.2*

**Strip and trench fill foundations shall be adequate, of a suitable depth and taken to a suitable bearing stratum. Issues to be taken into account include:**

- a) the home design and layout
- b) ground conditions
- c) frost susceptible soils and cold weather construction
- d) shrinkable and volume change soils.

#### The home design and layout

Foundation design should take account of site conditions, shape, size and construction of the homes. Foundations for terraced homes may require special precautions to prevent damage from differential settlement, while stepped foundations or suspended floors may be required for sloping sites.

The depth of foundations should provide a clean, firm and adequate bearing for the design loads.

#### Ground conditions

All relevant information about the history of the site, plus the nature and load-bearing capacity of the ground, should be available before the foundations are designed. Information may be available from:

- NHBC
- local authorities
- gas, water and electricity companies
- aerial photographs, Ordnance Survey maps and geological maps and surveys.

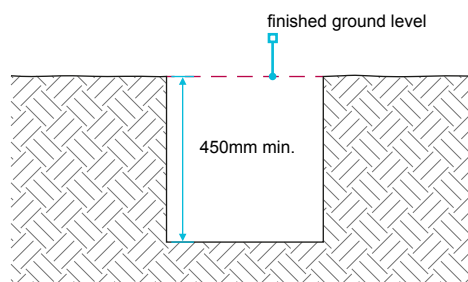
Site assessment surveys may require supplementary investigations involving trial pits and boreholes.

**Frost susceptible soils and cold weather construction**

In frost susceptible soils, e.g. chalk, the depth to the underside of the foundation should be at least 450mm below finished ground level, to avoid damage from frost action.

Additionally, when construction is undertaken during cold weather the foundation should either be at least 450mm below finished ground level, or alternatively, precautions should be taken to prevent freezing of the ground.

Where the finished ground level is to be above the existing ground level and cold conditions are expected, the foundation depth should be taken from the existing, not finished, ground level.



**Shrinkable and volume change soil**

The design should specify the minimum foundation depth.

**Table 1:** Minimum foundation depths in shrinkable soil

Modified Plasticity Index	Volume change potential	Minimum depth (m)
40% and greater	High	1.0
20% to less than 40%	Medium	0.9
10% to less than 20%	Low	0.75

Shrinkable soils are classified as containing more than 35% fine particles (clay and silt) and have a Modified Plasticity Index of 10% or greater.

These minimum depths may only be used where any existing or proposed trees or shrubs are outside the zone of tree influence. Heave is possible in shrinkable soil where trees have been, or are being, removed.

**Hazardous ground <sup>4.3.4</sup>**

*Also see: Chapters 2.1 and 4.2*

**Strip and trench fill foundations on hazardous ground shall be designed by an engineer, and notice given to NHBC before work commences.**

Where hazardous ground has been identified, NHBC must be notified eight weeks before work starts. Hazardous ground is defined in Chapter 4.1 'Land quality – managing ground conditions'.

**Setting out <sup>4.3.5</sup>**

**Strip and trench fill foundations shall be set out to take account of the design details.**

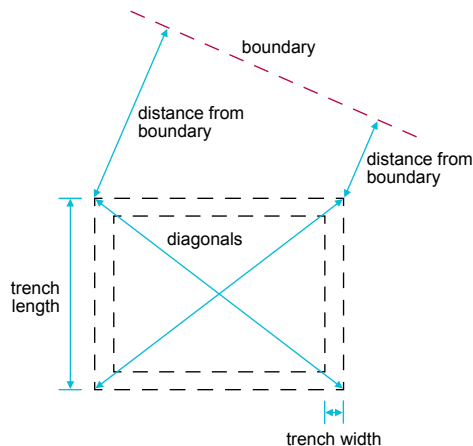
The accuracy of setting out should be checked by control measurements of trenches, including their location relative to site boundaries and adjacent buildings. Levels should be checked against accepted benchmarks.

For excavations, check:

- trench lengths
- trench widths
- length of diagonals between external corners.

Walls should be located centrally on the foundation, unless specifically designed otherwise.

Any discrepancy in dimensions should be reported promptly to the designer. Resulting variations should be distributed to all appropriate persons, including NHBC.



### Services and drainage <sup>4.3.6</sup>

Also see: Chapters 5.1 and 5.3

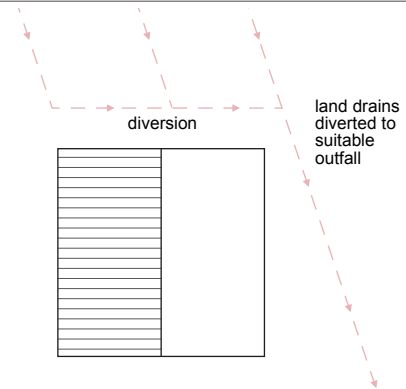
All strip and trench fill foundations shall be installed to:

- adequately protect existing services and ground water drainage
- make allowance for drainage and other services.

#### Adequately protect existing services and ground water drainage

Any existing services, such as cables, water pipes or gas mains, may need to be supported and protected. Services should not be rigidly encased in the foundations, and drains which are redundant should be cut open and filled or removed. Precautions should be taken to accommodate the effects of settlement where drains run under, or near to, a building.

Provision should be made to divert or protect any existing ground water drains affected by excavation work.



#### Make allowance for drainage and other services

Where services are to pass through or above foundations, provision should be made for suitable ducts or lintels to enable later installation.

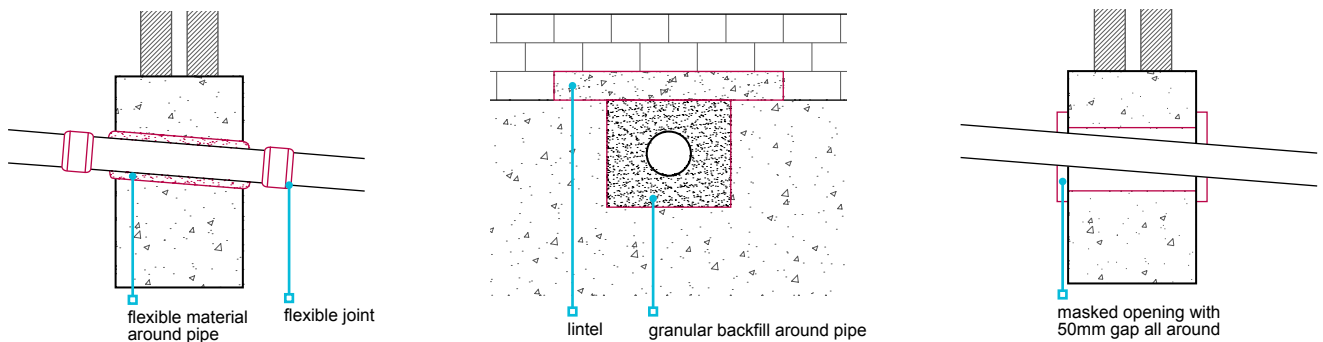
#### Strip foundations

Services should not pass through strip foundations but through the masonry above. Adequate lintels should be provided in the masonry.

#### Trench fill

The load-bearing capability of foundations should not be affected where services pass through. Services should be either sleeved or pass through a suitably strengthened opening in the foundation. This is to ensure that differential movement will not damage services.

For drainage, it is important to leave sufficient space for movement to ensure that the drain is capable of maintaining line and gradient.



### Safe transmission of loads <sup>4.3.7</sup>

Also see: BS 8103

Strip and trench fill foundations shall transmit loads to the ground safely and without excessive settlement, and take into account:

- dead and imposed loads
- foundation width and thickness
- stability of any adjoining building.

#### Dead and imposed loads

Dead and imposed loads should be calculated in accordance with:

BS EN 1991-1-1	UK National Annex to Eurocode 1. Actions on structures. General actions. Densities, self-weight, imposed loads for buildings
BS EN 1991-1-3	UK National Annex to Eurocode 1. Actions on structures. General actions. Snow loads
BS EN 1991-1-4	UK National Annex to Eurocode 1. Actions on structures. General actions. Wind actions
BS 648	Schedule of weights of building materials

All foundations should be:

- continuous throughout the building, including integral garages, porches, conservatories, bay windows, etc.
- symmetrical beneath load-bearing elements (i.e. walls should be located centrally on foundations).

### Foundation width and thickness

The width of the foundation should:

- be of sufficient width throughout to avoid overstressing the ground, especially where the foundation is required to support piers or columns
- depend on the load-bearing capacity of the subsoil and the loads from the building
- not be less than the wall thickness, plus at least 50mm each side.

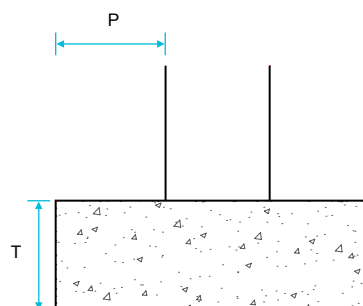
The width of strip foundations should account for ground conditions and be in accordance with the following table:

**Table 2:** Acceptable foundation widths

Type of ground (including engineered fill)	Condition of ground	Field test applicable	Total load of load-bearing walling not more than (kN/linear metre)					
			20	30	40	50	60	70
			Minimum width of strip foundation (mm)					
Rock	Not inferior to sandstone, limestone or firm chalk	Requires at least a pneumatic or other mechanically operated pick for excavation.	Equal to the width of the wall plus 50mm each side.					
Gravel Sand	Medium dense	Requires pick for excavation. Wooden peg 50mm square in cross-section is hard to drive beyond 150mm.	250	300	400	500	600	650
Clay Sandy clay	Stiff	Can be indented slightly by thumb.	250	300	400	500	600	650
Clay Sandy clay	Firm	Thumb makes impression easily.	300	350	450	600	750	850
Sand Silty sand Clayey sand	Loose	Can be excavated with a spade. Wooden peg 50mm square in cross-section can be easily driven.	400	600	Does not fall within the provisions of this guidance where the total load exceeds 30 kN/linear m.			
Silt Clay Sandy clay Clay or silt	Soft	Finger can be pushed in up to 10mm.	450	650				
Silt Clay Sandy clay Clay or silt	Very soft	Finger can be easily pushed in up to 25mm.	Refer to specialist advice.					

The thickness (T) of the foundation should be:

- equal to projection (P) or 150mm (whichever is greater)
- 150mm to 500mm for strip foundation
- 500mm minimum for trench fill foundations.



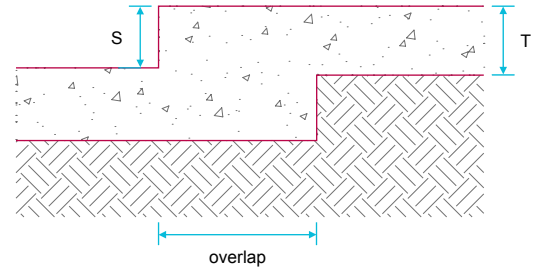
### Stability of any adjoining building

Where foundations are taken deeper than an adjoining building, excavation and construction will usually need to be carefully supervised by the design engineer, to check the standard of workmanship. Where necessary, allowance should be made in the design for differential movement.

### Sloping ground and stepped foundations <sup>4.3.8</sup>

**Strip and trench fill foundations shall be taken to a suitable bearing level when building on sloping ground, and steps shall be suitably formed.**

Sloping ground may require stepped foundations. Where foundations are stepped, the height of the step should not exceed the thickness of the foundation, unless it forms part of a foundation designed by an engineer in accordance with Technical Requirement R5.



**Table 3:** Foundation overlap

	Strip foundations	Trench fill foundations
The overlap should be not less than:	<ul style="list-style-type: none"> <li>■ 2 x S, or</li> <li>■ T (maximum 500mm), or</li> <li>■ 300mm, whichever is largest.</li> </ul>	<ul style="list-style-type: none"> <li>■ 2 x S, or</li> <li>■ One metre, whichever is largest.</li> </ul>

### Excavations <sup>4.3.9</sup>

*Also see: Chapter 4.2*

**Excavations for strip and trench fill foundations shall:**

- a) take account of the design dimensions
- b) take account of localised effects
- c) be compact, reasonably dry, even and correctly shaped.

#### Design dimensions

Inaccuracy may prevent walls and piers from being located centrally and therefore result in eccentric loading of foundations and possible foundation failure.

Excess excavation should be avoided. Accurate trench digging is particularly important where the width of the foundation is only slightly wider than the wall to be supported.

Acceptance from the foundation designer is required where the foundation design is modified.

#### Localised effects

At soft spots, excavations should be deepened to a sound bottom or the concrete should be reinforced. Hard spots should be removed.

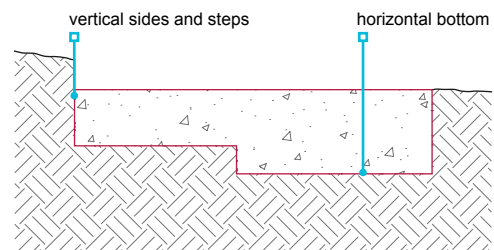
Where roots are visible at the bottom or sides of trenches, especially in clay soils, excavations may need to be taken deeper, or special precautions determined by an engineer in accordance with Technical Requirement R5.

#### Compact, reasonably dry, even and correctly shaped

Unless otherwise designed by an engineer in accordance with Technical Requirement R5:

- trench bottoms should be horizontal, with all loose material removed
- trench sides and steps should be, as near as possible, vertical.

Trench bottoms affected by rain water, ground water or drying should be rebottomed to form a sound surface.



### Reinforcement <sup>4.3.10</sup>

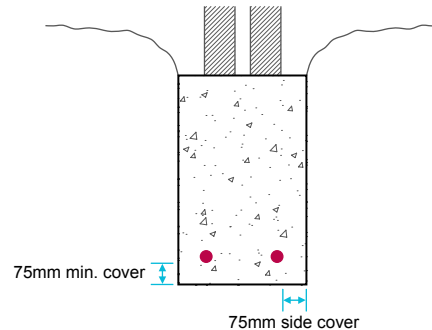
Also see: Chapter 3.1

**Reinforcement for strip and trench fill foundations shall ensure the safe transfer of loads and be suitable for localised ground conditions.**

Reinforcement should be:

- appropriately sized
- placed correctly
- clean and free from loose rust
- secured at laps and crossings
- supported to ensure that they are 75mm above the base of the foundation or as indicated in the design.

If in doubt about any soft spots, the designer's advice should be taken before placing the concrete.



### Concrete <sup>4.3.11</sup>

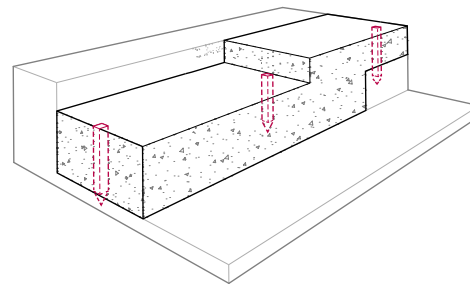
Also see: Chapters 3.1 and 3.2

**Concrete for foundations shall be:**

- a) of a mix which is suitable for the intended use
- b) durable against chemical or frost action
- c) correctly mixed, placed and cured.

Concreting should be carried out, as far as possible, in one operation, taking account of weather conditions and available daylight. Concrete should be placed as soon as possible after the excavation has been checked.

For trench fill foundations, it is particularly important to check that the finished level is correct and horizontal, as it is difficult to adjust for discrepancies in the small number of brick courses between the foundation and the DPC.



pegs used to ensure correct levels

### Movement joints <sup>4.3.12</sup>

**Strip and trench fill foundations shall have movement joints suitable for their intended purpose.**

Where movement joints are specified, they should be continuous with those in the superstructure.

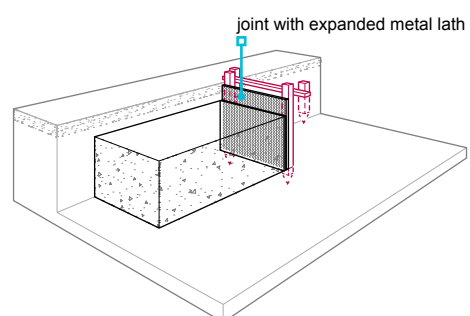
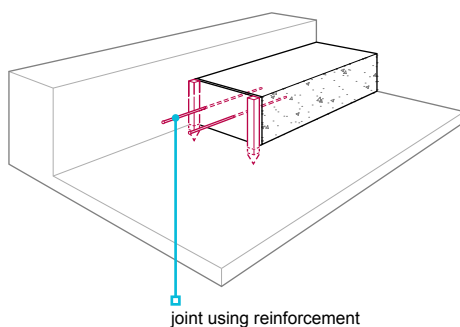
### Construction joints <sup>4.3.13</sup>

**Construction joints in strip and trench fill foundations shall be suitably formed.**

Where construction joints are unavoidable:

- they should not be positioned near a return in the foundation
- all shuttering should be removed before work continues beyond the construction joint.

Construction joints for strip and trench fill foundations may be formed by one of the methods shown below:



# Raft, pile, pier and beam foundations

## CHAPTER 4.4

This chapter gives guidance on meeting the Technical Requirements for raft, pile, pier and beam foundations.

4.4.1	Compliance	01
4.4.2	Provision of information	01
4.4.3	Site conditions	01
4.4.4	Hazardous ground	02
4.4.5	Services and drainage	02
4.4.6	Safe transmission of loads	03
4.4.7	Construction	03
4.4.8	Engineer checks	05
4.4.9	Compressible materials	05
4.4.10	Reinforcement	05
4.4.11	Concrete	05
4.4.12	Movement joints	05
4.4.13	Resistance to moisture	06



Raising Standards. Protecting Homeowners

### Compliance <sup>4.4.1</sup>

*Also see: Chapter 2.1*

**Raft, pile, pier and beam foundations shall comply with the Technical Requirements and provide adequate support to load-bearing elements.**

Raft, pile, pier and beam foundations that comply with the guidance in this chapter will generally be acceptable.

Relevant Standards and codes of practice include:

<b>BS EN 1991</b>	'Actions on structures'.
<b>BS EN 1992</b>	'Design of concrete structures'.
<b>BS EN 1997-1</b>	'Geotechnical design. General rules'.
<b>BS 10175</b>	'Investigation of potentially contaminated sites. Code of practice'.

Elements of the building requiring foundations include:

- external walls
- separating (party) walls
- internal load-bearing walls
- chimney breasts
- piers
- sleeper walls
- internal masonry walls.

### Provision of information <sup>4.4.2</sup>

**Designs and specifications shall be produced in a clearly understandable format, include all relevant information and be distributed to all appropriate personnel.**

All dimensions and levels should be indicated and relate to at least one benchmark and reference points on site. Design and specification information should be issued to site supervisors, relevant specialist subcontractors and/or suppliers, and include the following information:

- Dimensions, type and depth of foundations.
- Detailing of ducts.
- Junctions.
- Steps.
- Movement and construction joints.
- Location of services.
- Critical sequences of construction.

Both designers and site operatives need to be aware of:

- ground conditions
- any features requiring special attention, such as existing sewers or other services
- water table levels
- the presence of any hazardous substances including sulfates.

### Site conditions <sup>4.4.3</sup>

*Also see: Chapters 5.2 and 4.1*

**Raft, pile, pier and beam foundations shall be designed to take account of site conditions. Issues to be taken into account include:**

- a) the results of the site and ground appraisal
- b) dwelling design, layout and site levels
- c) trees and hedges
- d) frost susceptible soils
- e) potential for differential settlement.

#### Site and ground appraisal

All information relating to the site and its ground conditions which is necessary for full and proper foundation design should be obtained.

Building over changes in ground characteristics should be avoided.

#### Dwelling design, layout and site levels

Foundation design should take account of site layout, shape, size and construction of the dwelling.

Stepped foundations and suspended floors may be required for sloping sites.

#### Trees and hedges

Where the soil is shrinkable and nearby trees and hedges are existing, proposed or have been recently removed, foundations should be designed as shown in Chapter 4.2 'Building near trees'.



### Frost susceptible soils

To avoid damage from frost action, the depth to the underside of the foundation in frost susceptible ground should be at least 450mm below finished ground level.

### Differential settlement

Foundations should be designed to avoid any local stress points or any differential settlement.

Foundations for terraced homes, or those adjoining an existing building, may require special precautions to prevent damage from differential settlement. Foundations for attached bays, porches, garages, conservatories and other structures should be a continuation of those for the main home, unless the design indicates an alternative which takes account of differential movement.

### Hazardous ground <sup>4.4.4</sup>

*Also see: Chapters 3.1, 4.1, 4.2 and BRE Special Digest 1*

**Raft, pile, pier and beam foundations shall take account of ground conditions and hazards. Where hazardous ground has been identified, notice shall be given to NHBC before work commences.**

Where there is hazardous ground, the design of foundations must be carried out by an engineer in accordance with Technical Requirement R5.

Where hazardous ground has been identified, NHBC should be notified in writing at least eight weeks before work on site begins, in accordance with NHBC Rules.

Where toxic materials, or those likely to present a health hazard are found, all available information should be supplied to NHBC, together with proposals for remediation.

#### Sulfate and acids

Sulfates and other chemicals can cause expansion and disruption of concrete. High acidity, for example in peat, or permeable soil with acidic ground water can cause damage to concrete. Where sulfates or high acidity in ground or ground water are present, reference should be made to Chapter 3.1 'Concrete and its reinforcement' for guidance concerning acceptable concrete mixes.

Where concrete is at risk from chemical attack from the ground, or where the ground water is highly mobile, the level of sulfate and other chemicals should be determined in terms of the ACEC class (aggressive chemical environment for concrete class), in accordance with BRE Special Digest 1.

### Services and drainage <sup>4.4.5</sup>

*Also see: Chapters 5.1, 5.3 and 8.1*

**Raft, pile, pier and beam foundations shall take account of new and existing services. Issues to be taken into account include:**

- a) provision for new services
- b) adequate protection of existing services and drainage.

#### Provision for new services

Where services are to pass through, above or under foundations, openings should be provided using suitable ducts, sleeves or lintels that:

- are detailed so as not to impair structural stability
- do not affect the ability of the foundation to carry loads
- make suitable provision to allow for movement
- have sufficient space to maintain line and gradient of drainage where movement occurs.

#### Existing services and drainage

Existing services or drains should:

- be supported and protected
- be bridged, to prevent any load carrying
- not be rigidly encased in concrete, masonry, etc.

Land drains should be diverted to a suitable outfall; other drains should be diverted or bridged.

## Safe transmission of loads 4.4.6

Also see: Chapter 5.1

**Raft, pile, pier and beam foundations shall be designed to transmit loads from the structure to the ground safely, without excessive settlement.**

Raft, pile, pier and beam foundations should safely transmit loads. The following issues should be taken into account:

- adequate stiffness to ensure that differential movement does not adversely affect the supported structure
- nature and bearing capacity of the fill material to be placed under the foundation
- specification of concrete and cover to reinforcement.

**Raft and semi-raft foundations:**

Raft and semi-raft foundations should be designed:

- to prevent the erosion of ground beneath the raft
- (where required) to accommodate warm air ducts, service ducts or services without any adverse effect upon the performance of the foundation
- to limit the risk of ducts becoming flooded.

Fill for raft foundations should be in accordance with Chapter 5.1 'Substructure and ground-bearing floors'.

**Semi-raft foundations on made ground:**

The following notes are to be used as a guide for engineers designing raft foundations, but are by no means exhaustive.

Special consideration will be required for certain sites.

- Raft foundations are to be designed by a chartered civil or structural engineer taking account of ground conditions and the results of the site appraisal and ground assessment.
- Sufficient internal beams are to be provided to stiffen the slab adequately.
- The area between downstand beams should not be greater than 35m<sup>2</sup>.
- The ratio of adjacent sides on plan should not exceed 2:1.
- The minimum depth of perimeter and party wall beams is to be 450mm. On larger homes, some internal beams should be of the same depth as the perimeter beams.
- Perimeter and internal beams should be sufficiently wide at their base to carry their total loading at the allowable bearing pressure for the site.
- Beams are to be designed to span 3m simply supported and cantilever 1.5m.
- Beams are to use properly formed reinforcement in accordance with BS EN 1992-1-1.
- Where mesh is used in beams, it should be delivered to the site pre-bent.
- All beams should be cast on a minimum of 50mm concrete blinding.
- Minimum cover to reinforcement should be 40mm.
- Floor slabs should be a minimum 150mm thick, with nominal top face reinforcement as a minimum and anti-crack reinforcement in the bottom face, where appropriate.
- Stools or similar should be used to support floor slab mesh during casting.
- Corners and junctions to beams should be adequately tied using similar reinforcement to the beams.
- A minimum cavity drain of 225mm below the DPC is to be maintained.

**Piled foundations:**

The design of all piled foundations should specify precautions for cohesive soils where volume changes can occur.

The bearing capacity and integrity of piles should be confirmed by testing, when required.

## Construction 4.4.7

Also see: Chapter 4.2

**Raft, pile, pier and beam foundations shall be constructed in accordance with the design. Issues to be taken into account include:**

- a) setting out and excavations
- b) localised effects and trench bottoms
- c) installation of piles, piers and ground beams
- d) load capacity verification of piles.

**Setting out and excavations**

The accuracy of setting out should be checked by control measurements of trenches, including their location relative to site boundaries and adjacent buildings. Levels should be checked against benchmarks, where appropriate. For excavations, check:

- trench lengths
- trench widths
- length of diagonals between external corners.

In addition, for piled, pier and beam foundations, check:

- spacing
- alignment
- positions in relation to the proposed superstructure.

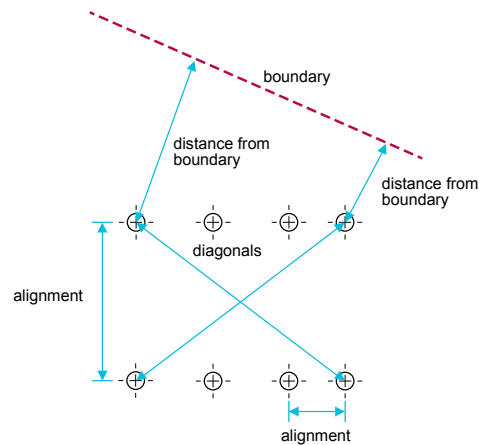
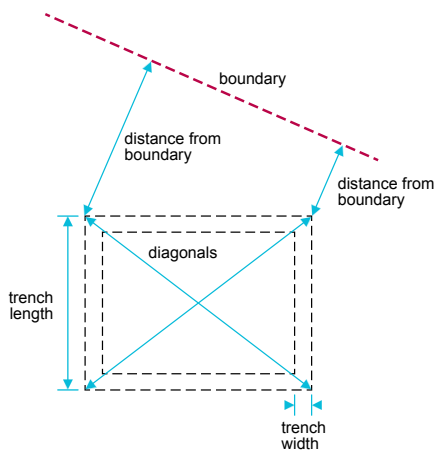
Walls should be located centrally on the foundation, unless specifically designed otherwise. Inaccuracy may prevent walls and piers being located centrally, resulting in eccentric loading and possible foundation failure.

Discrepancies to the design of the foundations or variations in the ground conditions should be reported formally to the engineer.

Variations in design or ground conditions should be recorded and distributed to NHBC and others concerned with sitework.

Foundation excavations should:

- be kept free from water
- not be excessive.



### Localised effects and trench bottoms

Trench bottoms affected by rain water, ground water or drying should be rebottomed to form a sound surface.

**Table 1:** Localised effects

Situation	Action
Differences in bearing capacity (e.g. from localised changes in strata)	Consult the engineer.
Soft spots	Excavations should be deepened locally to a sound bottom, or the concrete should be reinforced.
Hard spots	Should be removed.
Visible roots, especially in clay soils	Consult the engineer and modify the design depth.

### Installation of piles, piers and ground beams

Piles are to be installed by an appropriate specialist and under the supervision of an engineer.

Piles are to be vertical, unless designed otherwise.

Where piles are more than 75mm out of position, or out of alignment by more than 1:75, the engineer should reconsider the adequacy of the foundation design.

Where piles are misaligned by more than 150mm in any direction, or more than 5° from their specified rake, they should be replaced, unless otherwise recommended by the engineer. Alternatively, additional piles should be provided in accordance with the design modifications provided by the engineer.

Care should be taken to ensure that the bond of beams to piers and piles is in accordance with the design and is adequate.

### Load capacity verification of piles

Test loading of piles should be undertaken when required. The builder is to obtain written confirmation that the piles are suitable for their design load.

**Engineer checks** 4.4.8

**Engineer-designed foundations shall be inspected by the engineer during construction.**

The engineer should undertake site visits to ensure that the design of the foundation is suitable for the actual ground conditions encountered, and that the construction is in accordance with the design.

**Compressible materials** 4.4.9

*Also see: Chapter 4.2*

**Compressible materials shall be capable of absorbing potential heave forces.**

Materials used to accommodate heave should be assessed in accordance with Technical Requirement R3 and used in accordance with the manufacturer's recommendations and independent assessment when applicable.

**Reinforcement** 4.4.10

**Reinforcement of raft, pile, pier and beam foundations shall be in accordance with the design, sufficient to ensure the safe transfer of loads and be suitable for localised ground conditions.**

Reinforcement should be:

- appropriately sized
- placed correctly
- clean and free from loose rust
- secured at laps and crossings
- properly supported to ensure that the cover indicated in the design is maintained.

Reinforcement may be necessary, for example at construction joints or over small localised soft spots or changes in bearing strata.

**Concrete** 4.4.11

**Concrete for raft, pile, pier and beam foundations shall be:**

- a) of a suitable mix design to achieve the required strength and resistance to chemical and frost action
- b) correctly mixed, placed and cured.

Mixing, placing, testing and curing of concrete should be carried out as indicated in Chapter 3.1 'Concrete and its reinforcement' and when work is carried out in cold weather, Chapter 3.2 'Cold weather working'.

**Suitable mix**

Concrete should be of a mix which:

- will achieve the required strength and not impair the performance of the foundation
- is sufficiently resistant to chemical and frost action.

**Correctly mixed, placed and cured**

Before concrete is placed, excavations and reinforcement may need to be approved by the engineer or their representative and, in England and Wales, foundations should be approved by the person responsible for building control inspections.

Concreting should:

- be carried out in one operation (as far as possible)
- take account of weather conditions and available daylight
- be placed as soon as possible after the excavation or after the reinforcement has been checked
- be placed in even, compact and reasonably dry trenches.

**Movement joints** 4.4.12

**Raft, pile, pier and beam foundations shall have movement joints suitable for their intended purpose, and be formed using appropriate materials.**

Movement joints should be located so as to limit the risk of damage caused by movement. The design of movement joints and choice of sealing materials should consider:

- anticipated movement
- movement capability of seal
- designed joint width
- actual joint width
- joint depth
- surface preparation
- backing medium
- projected life span of the joint.

## Resistance to moisture 4.4.13

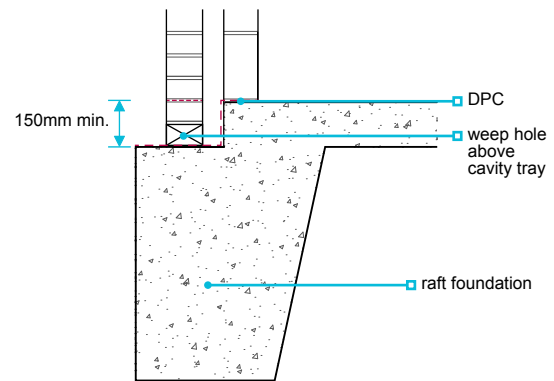
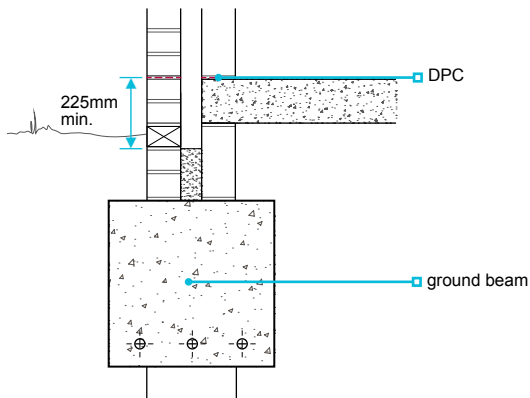
*Also see: Chapters 5.1, 5.2 and 5.4*

**Raft, pile, pier and beam foundations shall prevent the passage of moisture to the inside of the home and, where necessary, include a drained cavity and damp proof membranes.**

Cavity walls should drain below the DPC and should:

- prevent water crossing from the outside to the inside
- prevent the flooding of cavities above the DPC
- drain below the DPC
- have a minimum 225mm clear cavity below the DPC where strip, trenchfill or ground beams are used, or have a minimum 150mm clear cavity below the DPC where other types of foundations are used, provided that weep holes and other necessary measures are taken to ensure that the cavity can drain freely.

DPC cavity trays are not an acceptable waterproofing to the edges of specialised foundations, such as rafts and ground beams.



# Vibratory ground improvement techniques

## CHAPTER 4.5

This chapter gives guidance on meeting the Technical Requirements and recommendations for vibratory ground improvement techniques.

4.5.1	Compliance	01
4.5.2	Hazardous sites and ground hazards	01
4.5.3	Desk study and site investigation	01
4.5.4	Confirmation of suitability for treatment	02
4.5.5	Suitability of ground conditions	02
4.5.6	Compatibility of the ground, design and treatment	05
4.5.7	Acceptable methods	06
4.5.8	Materials for use as fill	07
4.5.9	Granular material	08
4.5.10	Sitework	08
4.5.11	Adjacent excavations	09
4.5.12	Verification of completed treatment	10



Raising Standards. Protecting Homeowners

### Introduction

The vibratory process is generally applied to weak natural soils and filled ground. The purpose is to improve the load-bearing capacity, reduce settlement and provide an adequate bearing stratum for the foundation supporting the home.

### Compliance <sup>4.5.1</sup>

*Also see: Chapter 2.1*

**Vibratory ground improvement techniques shall comply with the Technical Requirements and be designed by an engineer in accordance with established standards and codes of practice.**

Vibratory ground improvement techniques that comply with the guidance in this chapter, and that are in accordance with the relevant British Standards, building regulations and statutory requirements, will generally be acceptable.

Design of vibratory ground improvement, including foundations, should be carried out by an engineer experienced in ground improvement techniques in accordance with Technical Requirement R5. In this chapter, the term 'engineer' refers to an appropriate engineer who is independent of the contractor responsible for the vibratory ground improvement techniques.

British Standards, codes of practice and authoritative documents relevant to vibratory ground improvement techniques and site investigations include:

<b>BS 10175</b>	'Investigation of potentially contaminated sites – Code of practice'.
<b>BS EN 1991</b>	'Actions on structures'.
<b>BS EN 1997-1</b>	'General rules'.
<b>BS EN 1997-2</b>	'Ground investigation and testing'.
<b>BS EN 14731</b>	'Execution of special geotechnical works – Ground treatment by deep vibration'.
<b>BS EN ISO 14688</b>	'Geotechnical investigation and testing – Identification and classification of rock'.
<b>BS EN ISO 14689</b>	'Geotechnical investigation and testing – Identification and classification of rock'.
<b>BS EN ISO 22476</b>	'Geotechnical investigation and testing – Field testing'.
<b>BR 391</b>	'Specifying vibro stone columns'.
<b>ICE</b>	'Specification for Ground Treatment'.

### Hazardous sites and ground hazards <sup>4.5.2</sup>

*Also see: Chapter 2.1, 4.1 and 4.2*

**Vibratory ground improvement techniques on hazardous sites shall be reported to NHBC before work on site commences, and be designed to take account of the characteristics of the site, including any ground hazards.**

Hazardous sites, as defined in the NHBC Rules, should be reported to NHBC in writing at least eight weeks before sitework begins.

Details of ground hazards to be taken into consideration are given in Chapter 4.1 'Land quality – managing ground conditions' and Chapter 4.2 'Building near trees'.

### Desk study and site investigation <sup>4.5.3</sup>

*Also see: Chapter 2.1, 4.1 and 4.2*

**The engineer shall ensure a desk study and site investigation are undertaken and findings used to inform the design.**

The engineer should establish the scope of, and supervise, the site investigation, taking account of the findings of the desk study, and relevant standards listed in Clause 4.5.1.

The specialist contractor should be satisfied that the site investigation provides adequate and representative information in order to design the ground improvements. The results of the site investigation and desk study should be sent to NHBC prior to work starting and should, as a minimum, determine the items listed in Table 1.

**Table 1:** Results of the site investigation and desk study

Item to be determined	Guidance
Depths and properties of natural materials under the site	Includes the presence of caves, workings, or natural phenomena such as rocks or soils which dissolve or erode when exposed to the passage of water. Data for comparison with post-treatment properties should be established.
Extent and nature of any areas of filled ground on the site	Includes: <ul style="list-style-type: none"> <li>■ proportions and distribution of constituent materials</li> <li>■ state of compaction of the fill material throughout its depth</li> <li>■ grading and particle size distribution of fill materials</li> <li>■ potential for gas generation from fill materials</li> <li>■ potential for spontaneous combustion of fill and/or natural deposits.</li> </ul>
Presence and extent of any existing or redundant services and drains	Includes information on the extent and nature of the backfill to the excavations.
The effect of sustainable drainage systems	Includes the effect that any sustainable drainage system (SuDS) may have on the geotechnical parameters of the site.
Presence, level and nature of any ground water	Includes the potential for ground water to rise and cause heave or collapse by saturation.
Previous structures	Includes any potential underground obstructions or hard-spots, e.g. basement walls, floor slabs, which remain.
Occurrence of contaminated substances	Includes the presence and extent of contaminated substances or gases present or suspected.

### Confirmation of suitability for treatment <sup>4.5.4</sup>

*Also see: Chapter 2.1, 4.1 and 4.2*

**The builder shall obtain written confirmation from the engineer and specialist contractor that the site is suitable for the proposed ground improvement system.**

NHBC should be notified prior to work starting, that the site is suitable for the proposed system. The engineer and specialist contractor should agree the following in writing before work commences on site:

- Design objectives.
- Detailed schedule of work.
- Programme of work.
- Tests to be conducted on completion of the work.
- Responsibility for procedures and tests.

The following considerations should be taken into account:

- Layout and depth of the stone columns and the accuracy to be achieved.
- Safety issues to be incorporated into the design to allow for unforeseen circumstances.
- Criteria for non-acceptance of the vibrating poker worktests to be conducted on completion of the work.
- Responsibility for procedures and tests.
- Calculations and case histories required to justify the ground improvement proposals together with the layout of the stone columns and details of the equipment and process to be used on site.

These written agreements should be made available to NHBC before work commences on site.

### Suitability of ground conditions <sup>4.5.5</sup>

*Also see: Chapter 2.1, 4.1 and 4.2*

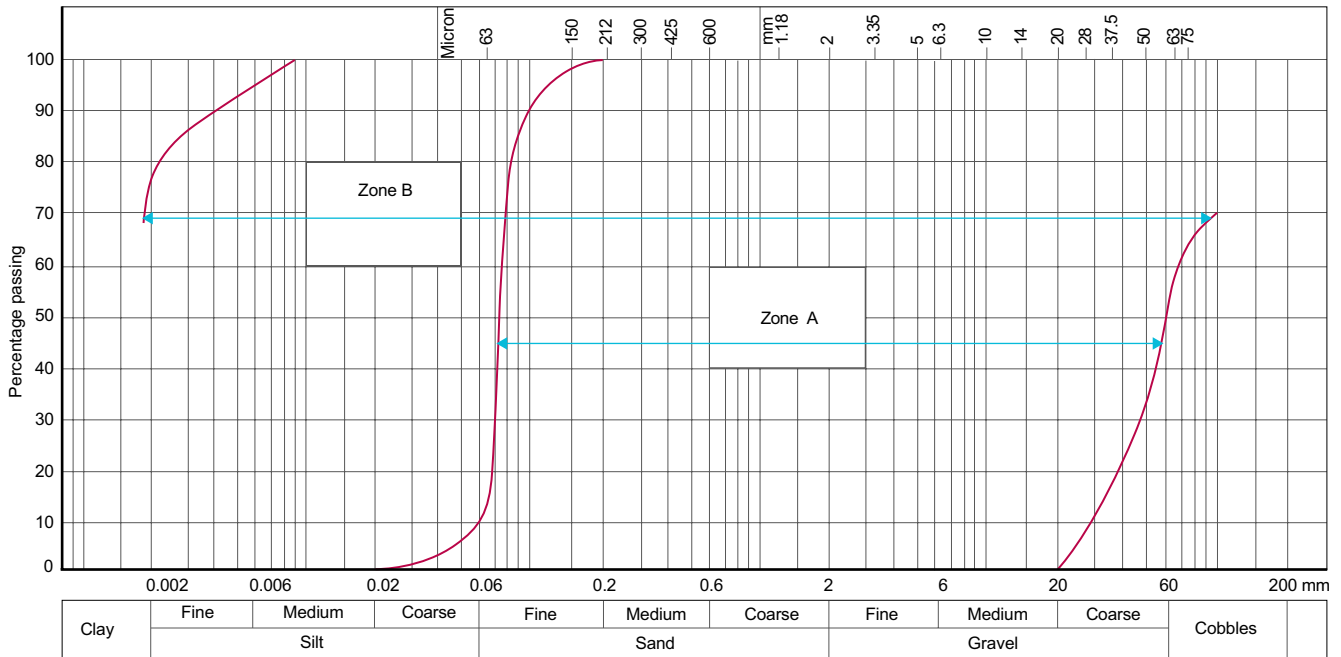
**Vibratory ground improvement techniques shall only be conducted on suitable ground and be appropriate for the site conditions. Issues to be taken into account include:**

- a) unsuitable ground conditions
- b) detrimental factors
- c) ground water conditions.

The engineer should assess the ground and be satisfied that it is suitable for treatment. Conditions acceptable for treatment are only those within zones A and B of Chart 1.



Chart 1: Conditions acceptable for treatment



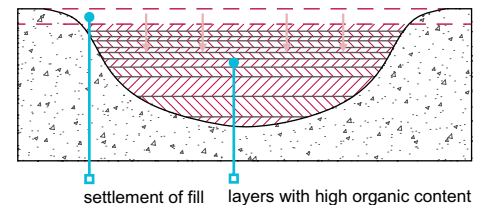
Zone A – range of materials suitable for deep compaction (vibro-compaction) techniques.

Zone B – range of materials suitable for stone column (vibro-replacement) techniques.

### Unsuitable ground conditions

Table 2: Ground conditions not generally acceptable for treatment

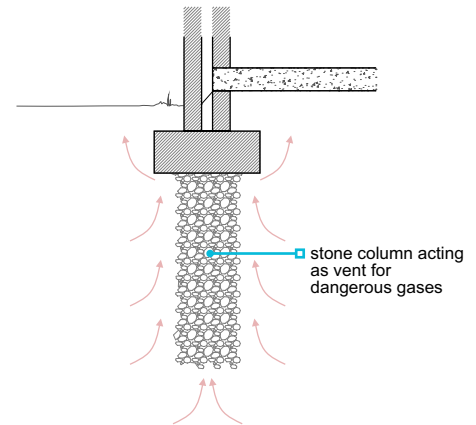
Soil composition	
Clays	Ground with a Plasticity Index greater than 40%.
Soft clays	Ground with soft clays with an undrained shear strength less than 30kN/m <sup>2</sup> . For clay strength less than 30kN/m <sup>2</sup> additional consideration must be given to group effects, ground heave and settlement due to installation. Any proposals will be subject to NHBC agreement.
Ground with peat layers	Ground with peat layers close to foundation level or the base of the stone column, or where intermediate layers of peat are thicker than 200mm either as a single layer, or the sum of the thicknesses of individual layers, throughout the length of the stone column.
Highly sensitive soils	Ground liable to collapse or remoulding.
Ground with fill	
Voided filled ground	Ground which includes, for example, old water tanks, pottery, glass bottles, concrete rubble or brick fill of unsuitable grading.
Loose or non-engineered fill	Ground with any loose or non-engineered fill not previously subject to rising or fluctuating water levels or saturation.
Filled ground which is still settling or expected to settle	Ground subject to settlement or settling: <ul style="list-style-type: none"> <li>under its own weight or due to the effects of surcharging/upfilling</li> <li>where there is a high organic content</li> <li>where decay is continuing.</li> </ul>
Fill containing degradable material	Ground where organic material forms more than 15% of fill by volume.



### Highly contaminated ground

Ground which includes, for example toxic waste, or where inflammable, explosive or toxic gas generation may take place

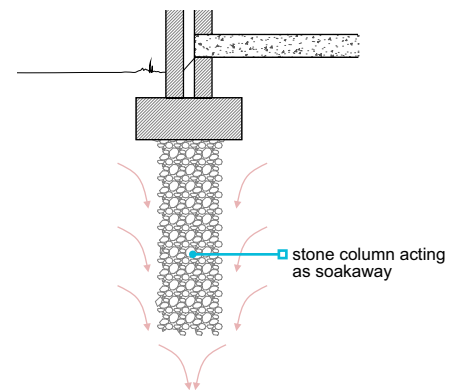
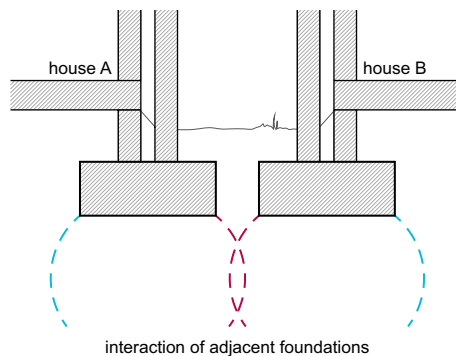
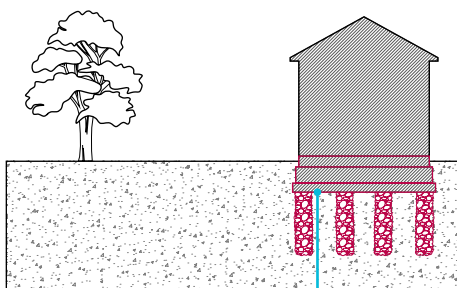
Stone columns may act as vertical vents. Consideration will be given to proprietary systems which do not permit vertical venting such as vibro concrete plug technology.



### Detrimental factors

When specifying vibratory ground improvement techniques, the following factors should be considered:

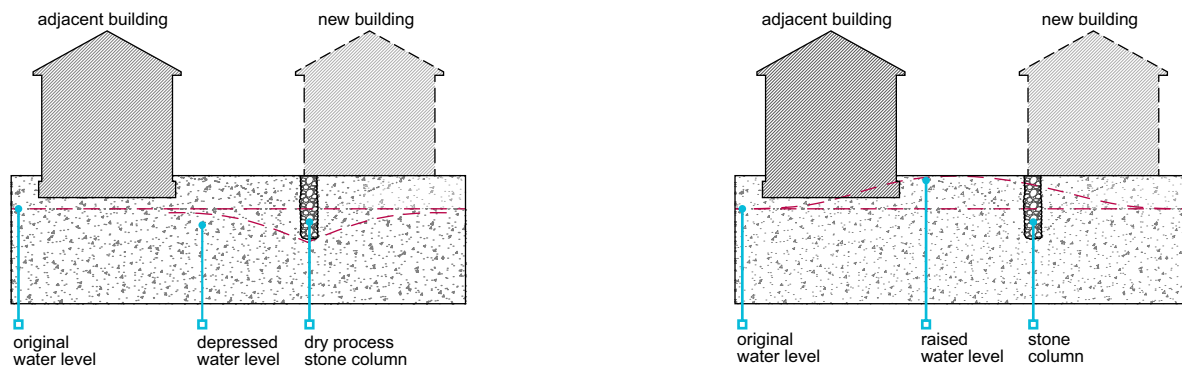
- Partial depth treatment of filled ground. The engineer should be satisfied with the anticipated performance of both the treated and untreated zones.
- The specialist contractor should take responsibility for the treated zone and the depth of treatment.
- Alterations to the oversite level before or after treatment, or the disturbance of ground by excavations after treatment.
- Soils with a Modified Plasticity Index of 10% or greater; foundations should be designed to accommodate volume changes.
- Obstructions and variations in the density of fill and natural ground (hard spots) and the location of changes in the profile of the natural underlying ground, e.g. edges of pits or quarries, slopes, or manmade obstructions such as soakaways or drainage runs.
- The minimum depth of soil treated, which should allow for the interaction of adjacent foundations.
- Stone columns that may form vertical drains, allowing the passage of water to a moisture-susceptible strata, or provide seepage paths for gases.



### Ground water conditions

When specifying vibratory ground improvement techniques, the following factors should be considered:

- Long-term lowering of the water table causing settlement of existing adjacent buildings.
- Short-term rise in local water table due to large volumes of water used in wet process during construction causing settlement or heave of existing adjacent buildings.



Surface water sewers should be used for rainwater disposal where possible, but where soakaways are necessary, these should be positioned so that their construction and operation is not detrimental to the treated ground.

The effect of any new or existing sustainable drainage systems (SuDS) should be taken into account when vibro improvement techniques are proposed.

### Compatibility of the ground, design and treatment <sup>4.5.6</sup>

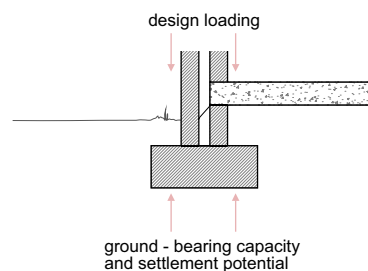
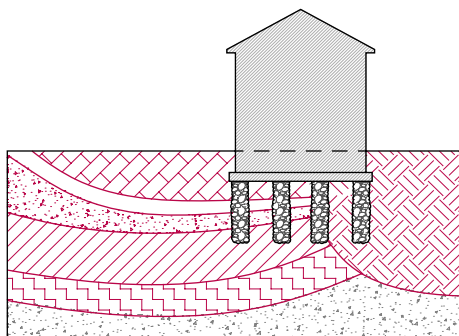
**Vibratory ground improvement techniques shall be compatible with the treated ground, site layout and the home design. Issues to be taken into account include:**

- limitations of the treated ground
- limitations of ground support
- suitable foundation types
- use of suspended ground floors
- notice to NHBC.

#### Limitations of the treated ground

The engineer should:

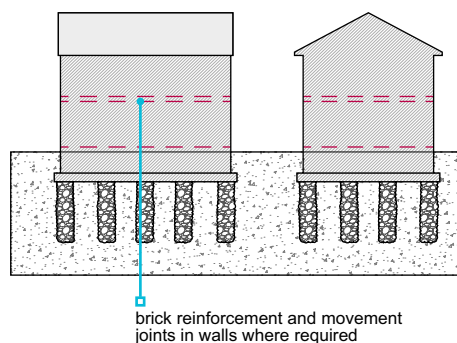
- avoid siting homes in locations where major changes in ground conditions can be expected
- consider limitations of the configuration of the homes including the vulnerability at junctions and of long blocks
- determine the loads to be imposed by the homes, and assess these against the results of the site investigation
- discuss the feasibility of proposals with the specialist contractor
- confirm the required load and settlement performance of the treated ground
- advise and discuss design criteria with NHBC at the design stage.



#### Limitations of ground support

The engineer should establish the likely limits of ground movement and account for this in the design, including:

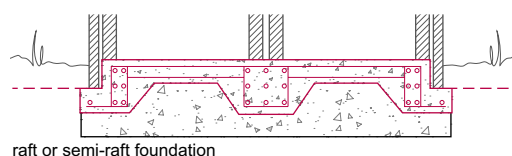
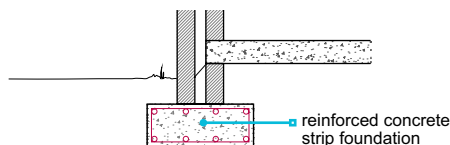
- the position and spacing of movement joints
- the flexibility of masonry mortars
- masonry reinforcement.



### Suitable foundation types

The following criteria should be incorporated in the foundation design to ensure the compatibility and overall stability of the foundations and superstructure:

- Only two types of foundations are suitable, both of which should comply with the minimum criteria for areas of reinforcement as defined in BS EN 1992-1-1. They are:
  - reinforced concrete strip foundation
  - reinforced concrete raft or semi-raft foundation positioned on a uniformly compacted bed of hardcore



- For both types of foundation, top and bottom reinforcement should be provided.
- The depth of foundations to be a minimum of 600mm below the surface of the treated ground, and founded on firm material of adequate bearing capacity.
- Where the treated ground is of a granular nature, a reinforced concrete strip foundation will normally be acceptable provided that the full depth of all fill material is treated.
- If the treated ground is of a cohesive nature, a suitably designed raft, semi-raft or reinforced concrete strip foundation will normally be acceptable.
- The reinforced concrete foundation should be designed to span between the centres of adjacent stone columns unless a more rigorous structural analysis is carried out to show that an alternative detail is acceptable.
- If partial depth treatment of filled ground is proposed then a suitably designed reinforced concrete raft or semi-raft foundation should be used.
- If during excavations for foundations in treated ground it is found that excessive depths of concrete are required, then precautions should be taken to ensure overall stability of the foundations, and the engineer should be satisfied that construction of the foundation will not be detrimental to the treated ground.

### Use of suspended ground floors

Suspended ground floors should be provided for all homes where vibratory ground improvement has been conducted, unless the engineer can substantiate an alternative solution that is acceptable to NHBC.

#### Notice to NHBC

Where vibratory ground improvement is proposed, NHBC should be informed of:

- proposed development
- proposed start date of treatment.
- appointment of the specialist contractor

### Acceptable methods <sup>4.5.7</sup>

**Vibratory ground improvement techniques shall only be conducted using methods that are appropriate to the ground conditions and acceptable to NHBC.**

There are two main vibratory methods commonly used in the UK. These are known as the 'dry bottom feed' and 'dry top feed' methods. A third method, infrequently used in the UK and known as the 'wet bottom feed', is also acceptable to NHBC.

#### Dry bottom feed method

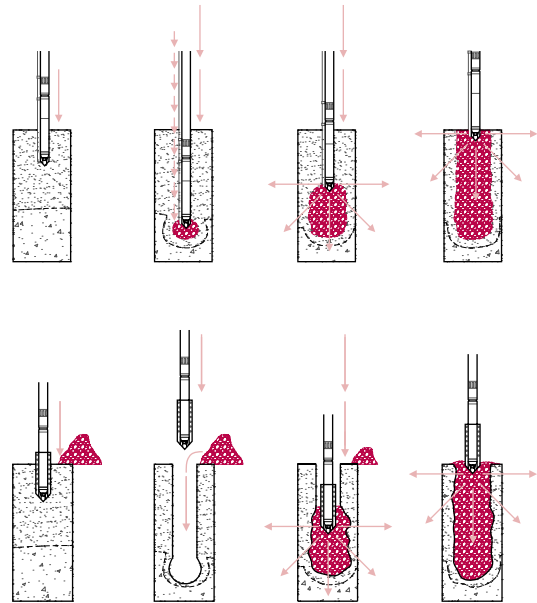
The dry bottom feed method is adopted in weaker soils or situations where there is a high water table and the bore hole is liable to collapse between vibrator insertions.

The vibrator penetrates by its mass, air flush and vibration. At design depth, the stone is introduced via a hopper into a pipe fixed to the side of a vibrator. The stone, generally of 40mm size, exits the pipe at the tip of the vibrator and discharges into the bottom of the bore hole. The stone is then compacted into the surrounding soil by repeated withdrawal and insertion of the vibrator.

### Dry top feed method

The dry top feed method is only used on cohesive soils where the bore hole can remain open. The vibrator penetrates the weak soil, or fill, by its mass, air flush and vibration to form a bore hole.

Once refusal or design depth is reached, the vibrator is removed and stone fill introduced into the bore hole, the 'charge' is generally 500-800mm deep. The vibrator is re-inserted and 'packs' the stone into the surrounding strata. Successive charges of stone are added and compacted, bringing the column up to working level. The stone grading is generally 40-75mm.



### Materials for use as fill <sup>4.5.8</sup>

*Also see: BRE Special Digest 1 Part 1, BRE Special Digest 433 and BS EN 771*

**Stone fill for forming columns shall be compatible with the ground conditions, and be suitable for the vibratory ground improvement process.**

Column fill should be a clean, hard, inert material. Limestone fill may not be acceptable in acidic ground conditions.

#### Suitable sources for fill material

All material used for fill should be suitable.

Where the material is of a stable and uniform type from one source, it may only be necessary to check its suitability once. Regular inspections and/or testing may be required where material is variable or from a number of sources.

Where material is obtained from stockpiles, the uniformity should be checked. Different forms of stockpiling can affect particle size and grading. The outside of a stockpile may be weathered and may not be the same as unweathered material. The use of recycled aggregate as fill should comply with BRE Digest 433 or other suitable guidance as agreed with NHBC.

**Hazardous materials**

The following materials require testing to ensure their suitability for use as fill to support structural foundations and slabs, or as backfill to associated trenches:

- Acid wastes.
- Reactive materials.
- Materials that include sulfates, e.g. gypsum.
- Organic materials.
- Toxic materials.
- Materials that cause noxious fumes, rot, undue settlement or damage to surrounding materials.

**Test requirements for fill material**

Tests should be carried out by a suitably qualified person with a detailed knowledge of the:

- material to be tested
- proposed conditions of use.

The samples which are tested must be representative of the true nature of the material. It may be necessary to take a number of samples to find out the material characteristics of the fill.

Sulfate content should be expressed as a percentage  $SO_4$  by weight on the basis of acid soluble testing, taking full account of the recommendations of BRE Special Digest 1 Part 1.

**Fill material requiring NHBC approval**

The following types of fill should not be used unless written permission has been obtained from NHBC:

- Colliery shale and any other residue from mineral extraction.
- Slags.
- Furnace ashes and other products of combustion.
- Material obtained from demolition.
- On wet sites, or sites with a high water table, crushed or broken bricks which have no limit on their soluble salt content (as defined in BS EN 771).

**Expansive fill materials**

Fill containing expansive material is not acceptable for use as support to structural foundations and slabs, or as backfill to associated trenches.

**Granular material** 4.5.9

**Granular material for raising site levels before treatment, or adding during deep compaction, shall be suitable for compaction and, unless appropriate precautions are taken, be free from hazardous materials.**

The grading of material for adding during deep compaction should be within Zone A of Chart 1. Well graded, inert fill which passes a 100mm x 100mm screen in all directions and contains less than 10% fine material of silt or clay size will generally be acceptable for raising site levels.

Precautions, including testing where appropriate, should be taken where hazardous materials are present in fill.

**Sitework** 4.5.10

**When using vibratory ground improvement techniques, the builder shall ensure that the engineer visits the site and provides competent supervision throughout the ground treatment process. Issues to be taken into account include:**

- a) engineer checks
- b) location, depth and alignment of columns
- c) managing unforeseen circumstances.

**Engineer checks**

The engineer should provide competent site supervision throughout the ground treatment process and at critical stages, including:

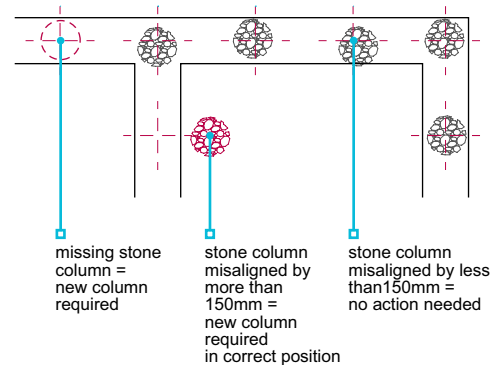
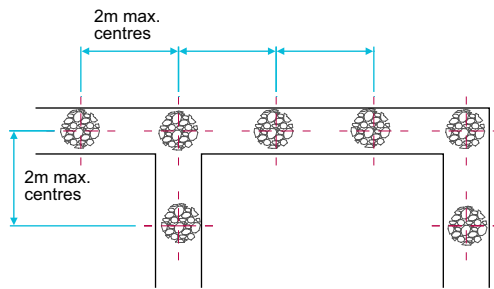
- the inspection of setting out
- the installation of columns during the early stage of the work
- checking of materials
- where installation data differs from design assumptions
- where changes in treatment layout are required.

Some aspects of sitework may be the responsibility of the engineer or their representative, or of the specialist contractor, rather than of the builder.

### Location, depth and alignment of columns

Supervision should ensure that:

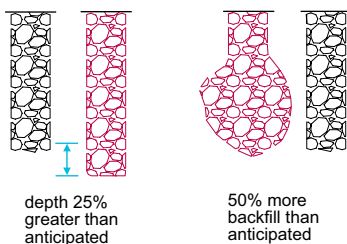
- the minimum required depth of the stone columns is achieved and each one correctly located (the builder should provide sufficient profiles to enable locations to be checked)
- the stone columns are located either centrally under the foundations they are to support or are in the predetermined staggered arrangement, at a maximum of 2m centres and at the intersection of adjacent reinforced concrete strips
- missing stone columns are replaced
- stone columns which are misaligned by more than 150mm in any direction are replaced
- the location of all stone columns is checked by the engineer's representative prior to the specialist plant leaving the site.



### Managing unforeseen circumstances

**Table 3:** Actions for managing unforeseen circumstances

Circumstance	Action	In all cases
Unforeseen changes or trends which affect the site conditions	Recorded and reported to the engineer immediately	Where there is an effect on the final efficiency of the treatment, this should be fully considered by the engineer and the specialist contractor. The builder and NHBC are to be advised immediately regarding proposed remedial measures.
Change in the anticipated depth of the compaction point in excess of 25%	Recorded and reported to the engineer and specialist contractor as soon as possible but no later than the end of the working day of occurrence	
Variation of over 50% in the quantity of backfill used in compaction points of the same length		



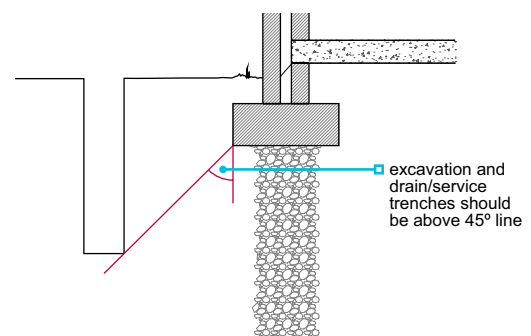
Allowance should be made for unforeseen obstructions that require either local removal and backfilling prior to treatment, realignment or additional columns, coupled with local amendment of foundation design.

### Adjacent excavations <sup>4.5.11</sup>

**The builder shall ensure that foundations are not disturbed by adjacent excavations.**

The engineer should consider the influence of drainage and other service trenches on the stability of the complete design.

The minimum clearance between excavations and foundations must not be less than the depth of excavation minus the depth of the structural foundation. Particular attention is needed for excavation below the water table.



**Verification of completed treatment** <sup>4.5.12</sup>

The engineer shall require the specialist contractor to verify that the ground treatment is satisfactory, including:

- a) suitable testing
- b) written confirmation of completed treatment
- c) recording of work.

**Suitable testing**

Tests should be carried out to establish the degree of ground improvement, the load-bearing characteristics and settlement potential.

The specialist contractor should:

- predict the results from his experience of work on the type of ground prior to the test taking place
- agree results and tolerance with the engineer prior to testing
- agree results and tolerance with the engineer with actual results.

Where the results are vastly different, a further investigation may be necessary.

Where a threefold improvement were predicted and only a twofold improvement achieved, this could indicate that the ground was different to that identified in the investigation, or that the treatment carried out differed from the specified treatment.

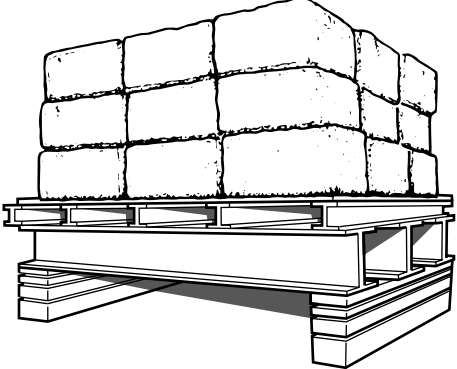
Tests on ground containing clay soils may need to be conducted several days after completion to allow excess pore pressures to dissipate. The engineer may choose any appropriate combination of the tests detailed in Table 4, with the agreement of NHBC.

**Table 4:** Test methods

Test	Comments
600mm diameter plate tests	<p>Plate tests will not determine the design but will allow for an assessment to be made of the workmanship on the stone columns.</p> <p>The tests should be carried out on stone columns or treated ground at a frequency of at least one test per day per rig.</p>
Dummy footing test/mini zone test	<p>A mini zone test can be used as a limited substitute for zone tests. The test should be applied to at least two stone columns and the area of foundation which they support. The load may be applied through a rigid beam or stiffened plate using skips or other known loads, arranged to give a uniform distribution of the load.</p> <div data-bbox="973 1164 1436 1478" data-label="Image"> </div> <p>Mini zone tests should be continued for a sufficient time to allow creep behaviour to be quantified. Allowances for this time should be made in the overall project programme.</p>



Table 4 (continued): Test methods

Test	Comments
Zone test	<p>An isolated pad or strip footing is used to test up to eight stone columns and the intervening ground. Loadings which should simulate the dwelling loads are held for 24 hours at predetermined stages to examine creep behaviour.</p> 
In-situ test	<p>Where vibration will improve the ground itself, e.g. granular materials, then in-situ testing is appropriate. Improvement can be assessed when the in-situ test results are compared with the pretreatment investigation.</p>
Trial pits	<p>Trial pits can be excavated around trial stone columns to prove that they are fully formed and to the required depth and diameter. This is a destructive test, and allowance should be made accordingly.</p>

### Written confirmation of completed treatment

On completion of the treatment, the engineer should:

- use the test results to verify that the treated ground has achieved the anticipated condition assumed in the design
- advise the builder and NHBC in writing of the verified effectiveness of treatment in relation to the design
- advise the builder of any special precautions which should be taken for the positioning of services both beneath the home and adjacent to it.

### Recording of work

A comprehensive record of all works should be made available to NHBC, including:

- information concerning the treatment
- depth of fill
- volume of stone used
- on-site changes
- any other relevant information.

# Substructure and ground-bearing floors

## CHAPTER 5.1

This chapter gives guidance on meeting the Technical Requirements and recommendations for substructures (excluding foundations), including substructure walls, ground-bearing floors where infill is no deeper than 600mm, and installation of services below the damp proof course (DPC).

5.1.1	Compliance	01
5.1.2	Provision of information	01
5.1.3	Transfer of loads	01
5.1.4	Ground conditions	01
5.1.5	Services and drainage	02
5.1.6	Ground below fill	03
5.1.7	Fill below floors	03
5.1.8	Fill up to 600mm deep	04
5.1.9	Materials used for fill	04
5.1.10	Harmful or toxic materials	04
5.1.11	Regulatory solutions	05
5.1.12	Walls below the DPC	05
5.1.13	Durability	06
5.1.14	Mortar	07
5.1.15	Wall ties	07
5.1.16	Blinding	07
5.1.17	Ground floor slab and concrete	07
5.1.18	Laying the ground-bearing floor slab	08
5.1.19	Damp proof course	08
5.1.20	Damp proofing concrete floors	09
5.1.21	Thermal insulation	09
5.1.22	Installation of insulation	10
5.1.23	Further information	10



Raising Standards. Protecting Homeowners

### Compliance <sup>5.1.1</sup>

*Also see: Chapter 2.1*

#### **Substructures and ground-bearing floors shall comply with the Technical Requirements.**

Substructures and ground-bearing floors that comply with the guidance in this chapter will generally be acceptable.

Ground-bearing floors may only be used where the depth of infill is less than 600mm deep and properly compacted.

### Provision of information <sup>5.1.2</sup>

#### **Designs and specifications shall be produced in a clearly understandable format, include all relevant information and be distributed to appropriate personnel.**

Design and specification information should be issued to site supervisors, relevant specialist subcontractors and suppliers, and include the following information:

- Plan dimensions and levels which should be related to benchmarks.
- The required sequence and depth of trench backfill where relevant to the design of the walls below the DPC.
- Details of trench backfill, infill and void formers
- Work required to maintain the integrity of DPCs and damp proof membranes (DPMs).
- Information on proposed underground services, including points of entry to the building.
- Detailing of service penetrations through the substructure, including support of the structure above details of junctions between the DPM, DPC and tanking.
- Details of underfloor, floor edge and cavity insulation.

### Transfer of loads <sup>5.1.3</sup>

*Also see: Chapters 4.1, 4.3, 5.2 and 6.1*

#### **Substructures and ground-bearing floors shall ensure that loads are supported and transferred to the foundations, or ground, without undue movement.**

The design of the substructure should take account of findings from the site investigation. Where infill deeper than 600mm is needed, a suspended floor should be used.

Load-bearing partitions should have proper foundations and not be supported off ground-bearing floors. In Scotland, sleeper walls should not be built on ground-bearing floors.

### Ground conditions <sup>5.1.4</sup>

*Also see: Chapters 4.1, 4.2, 5.2 and BRE Report 211*

#### **Substructure and ground-bearing floors shall not be adversely affected by ground conditions, and take account of:**

- |                                   |  |
|-----------------------------------|--|
| a) ground hazards                 | d) effect of sloping ground on depth of infill and wall construction |
| b) bearing capacity of the ground | e) site works and construction.                                      |
| c) nature of the ground           |  |

#### **Ground hazards**

Hazards likely to affect substructure and ground-bearing floors include contaminated materials, waterlogged ground and chemicals, particularly sulfates.

Where it is necessary to reduce the entry of radon gas, which should be identified in the site investigation, such precautions should be acceptable to NHBC.

#### **Bearing capacity**

Ground-bearing floors may not be suitable where the bearing capacity and nature of the ground varies, even where the depth of infill is less than 600mm. Special measures may be needed to restrict settlement, such as the use of suspended floor construction.

#### **Nature of the ground**

Where there is shrinkable soil, expansive materials or other unstable soils, suspended floor construction may be necessary.

Shrinkable soils are classified as those which contain more than 35% fine particles (silt and clay) and which have a Modified Plasticity Index of 10% or more. A soil testing laboratory should be consulted to verify the Plasticity Index of the soil.

### The effect of sloping ground

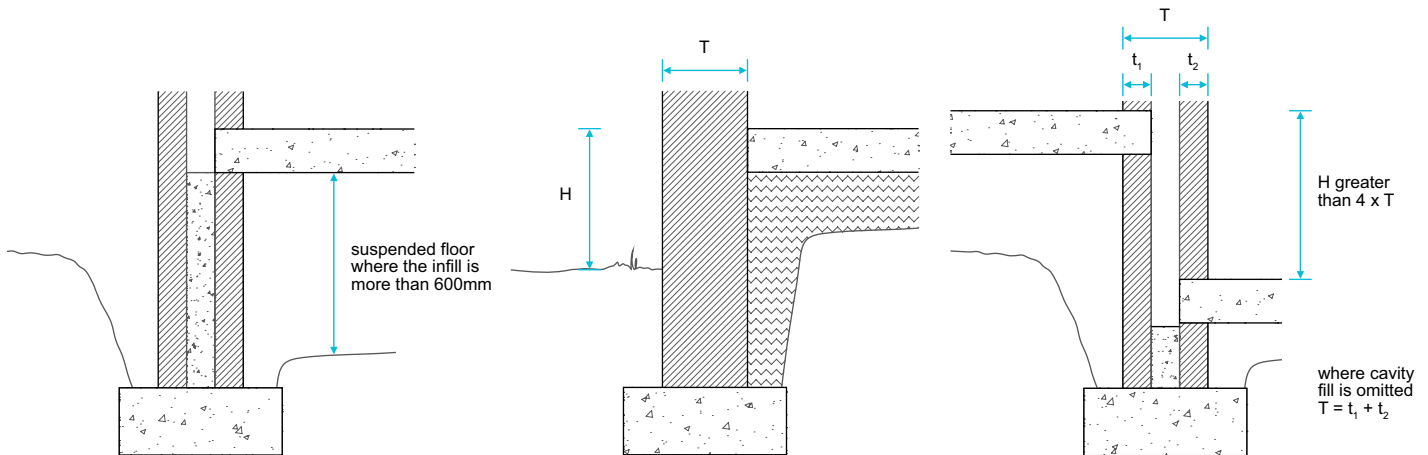
Sloping ground may require steps in the substructure and possibly different floor levels.

Where more than 600mm of infill is required at any point in a self-contained area, the floor over the whole of that area must be of suspended construction.

Construction on steep slopes may involve walls below DPC level acting as retaining walls and should be designed by an engineer where (H) is greater than four times (T).

■ (H) = height difference between floor/ground levels

■ (T) = the total thickness of the retaining wall.



### Site works and construction

Special precautions may be needed to prevent damage to the substructure from site operations on adjoining ground such as ground treatment, or surcharging due to infill.

### Services and drainage <sup>5.1.5</sup>

*Also see: Chapters 5.3, 5.4, 6.2 and 8.1*

**Substructure and ground-bearing floors shall be installed to:**

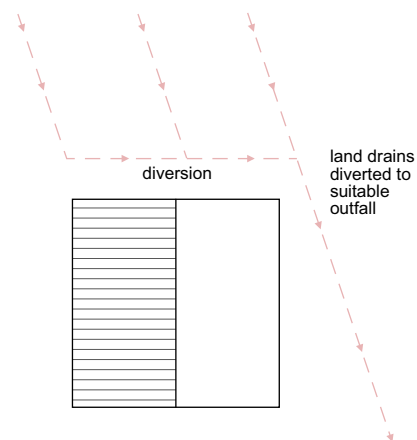
- a) adequately protect existing services and ground water drainage
- b) have suitable surface and subsoil drainage
- c) make allowance for drainage and other services.

### Adequately protect existing services and ground water drainage

All existing services should be located and identified before work commences. During dry periods it can be difficult to determine if ground water drains are active, so where they are severed or disturbed, they should be reconnected to a suitable outfall.

Existing active groundwater drainage should be retained to minimise the risk of flooding. Water from these drains may require diverting.

Where existing services conflict with the proposed foundations or substructure, and they are to remain, they should be protected or diverted and remaining voids filled with concrete or grout. Where they are no longer active and are not needed, they should be disconnected and grubbed up.



### Surface water and subsoil drainage

Surface and/or subsoil drainage may be needed on sites where there is a risk of waterlogging.

Walls which act as retaining walls may require land drains, hardcore fill and suitable outlets to dispose of any subsoil water that collects behind the wall.

Ground or paths adjoining the home should:

■ slope away at a slight fall

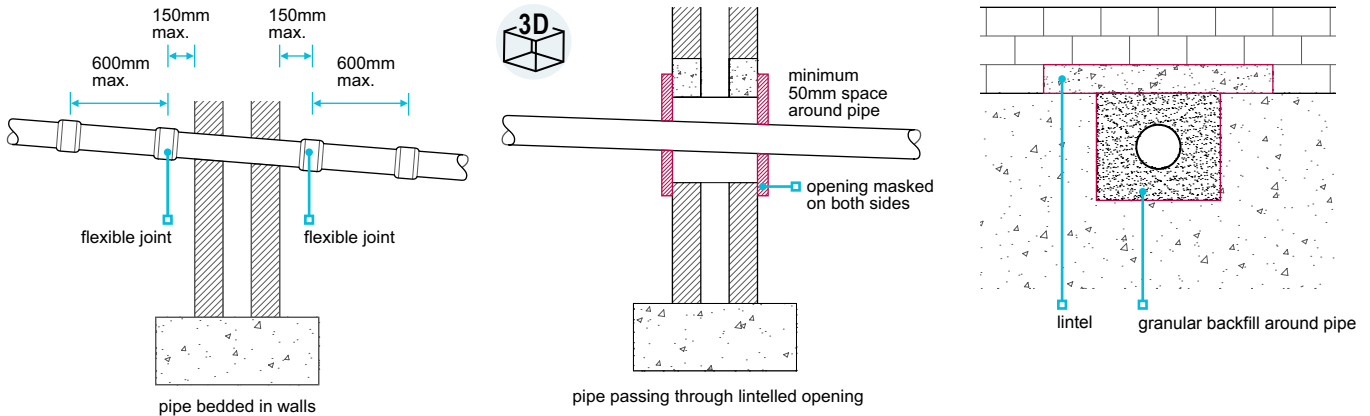
■ generally be at least 150mm below the DPC.

### Make allowance for drainage and other services

Design information should include all necessary details relating to the proposed underground services.

Drain pipes passing through or under the building may require flexible connections or other means of accommodating differential movement.

Where pipes penetrate walls, they should be provided with flexible joints or be sited in an opening formed by lintels.



Services should be sleeved where they pass through a structural element. Where required, they should be arranged so that future access can be obtained without affecting structural stability.

When unidentified services, ducts, cables or pipes are exposed, advice should be sought from local offices of statutory undertakings and service supply companies.

### Ground below fill <sup>5.1.6</sup>

**Ground below fill shall be adequately prepared to provide consistent support to the fill and the ground-bearing slab without undue movement.**

Ground-bearing floor slabs may only be built on ground where:

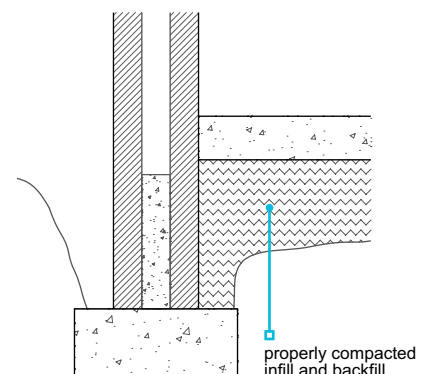
- the ground is suitable to support floor loads and any other loads
- all topsoil containing vegetation and organic matter, including tree roots, has been removed
- there is a suitable and even bearing surface.

### Fill below floors <sup>5.1.7</sup>

**Fill, including made ground, trench backfill and infill below ground-bearing floor slabs shall provide full and consistent support to ground-bearing slabs.**

Where more than 600mm of infill is required at any point within a self-contained area, or the bearing capacity and nature of the ground varies, the floor over the self-contained area should be of suspended construction.

Infill under slabs and backfill in trenches should be properly placed and mechanically compacted to form a stable mass in layers not exceeding 225mm. Concrete may be used as an alternative to backfill in trenches.



### Infill up to 600mm deep <sup>5.1.8</sup>

Also see: Chapter 5.2

#### Infill beneath ground-bearing floors shall be a maximum of 600mm deep.

Ground-bearing slabs are not acceptable where infill exceeds 600mm in depth.

Where the design requires in excess of 600mm of infill at any point within a self-contained area, the floor construction over the whole of that area is required to be independent of the fill and capable of supporting:

- self-weight
- non load-bearing partitions
- other imposed loads.

### Materials used for fill <sup>5.1.9</sup>

Also see: BRE DG 522 'Hardcore for supporting ground floors of buildings'

#### Materials used for fill shall be suitable for the intended use and, unless appropriate precautions are taken, free from hazardous materials. Issues to be taken into account include:

- a) sources of fill materials
- b) hazardous materials.

Fill should be:

- well graded
- inert and contain no hazardous materials
- able to pass a 150mm x 150mm screen in all directions.

Fill containing either expansive materials or chemicals is not acceptable for the support of ground-bearing slabs.

The following types of fill should not be used unless written permission has been obtained from NHBC:

- material obtained from demolition
- furnace ashes and other products of combustion
- colliery shale and any other residue from mineral extraction
- slags
- on wet sites, or sites with a high water table, crushed or broken bricks which have S1 designation according to BS EN 771.

### Sources of fill material

Where the material is of a stable and uniform type, and from one source, it may only be necessary to check its suitability once. Where material is variable, or from a number of sources, it should all be suitable, and regular inspections and/or testing may be required.

Where industrial waste is permitted as fill material, it is essential that sufficient testing is carried out to ensure suitability.

Where material is obtained from stockpiles, check the material is uniform. Different forms of stockpiling can affect particle size/grading. The outside of a stockpile may be weathered and may not be the same as unweathered material.

### Hazardous materials

The following fill materials require testing to ensure their suitability for use with ground-bearing slabs or as backfill to associated trenches:

- reactive materials
- organic materials
- toxic materials
- materials that include sulfates, e.g. gypsum
- materials that cause noxious fumes, rot, undue settlement or damage to surrounding materials
- acid wastes.

### Harmful or toxic materials <sup>5.1.10</sup>

Also see: BRE DG 522 'Hardcore for supporting ground floors of buildings'

#### Harmful or toxic materials present in the fill or in the ground shall be identified to the satisfaction of NHBC and not affect the performance of the substructure and ground-bearing slab.

Precautions should be taken by either:

- ensuring that made ground and fill materials are free from harmful or toxic substances, or
- designing the construction to contain, resist and prevent the adverse effects of such materials, using means acceptable to NHBC.

Tests for sulfate content should comply with the recommendations of BRE Special Digest 1 Third Edition by a suitably qualified person who has a detailed knowledge of the:

- material being tested
- proposed conditions of use.

The samples tested must be representative of the material, so it may be necessary to collect multiple samples to identify characteristics.

Where there are likely to be harmful levels of sulfate:

- the floor slab should be of an appropriate mix to resist sulfate attack or be protected by an impervious layer of 1200 gauge (0.3mm) polyethylene sheet, or 1000 gauge (0.25mm) where it complies with Technical Requirement R3. This may also serve as a DPM
- the concrete blocks in substructure walls should be sulfate resistant and suitable for the fill and ground conditions
- the mortar should be sulfate resisting to comply with of BS EN 1996-1-1.

Fill containing expansive materials or chemicals is no acceptable for use as infill or backfill.

### Regulatory solutions <sup>5.1.11</sup>

**Use of recycled or secondary materials shall comply with the relevant waste regulatory requirements.**

**Table 1:** Regulatory solution for fill, including recycled and secondary materials

Location	Materials used on:	Regulatory solution
England and Wales	Site of origin	CL:AIRE Code of Practice.
	Other sites and less than 5000t	Registration under a U1 exemption with the EA is required at the receiving site.
	Other sites and over 5000t	Ensure that the supplier has followed the WRAP protocol.
Northern Ireland and Scotland	Any site	Registration under a paragraph 19 exemption with the SEPA/NIEA is required at the receiving site.

EA: Environment Agency

CL:AIRE: Contaminated Land: Applications in Real Environments.

NIEA: Northern Ireland Environment Agency

SEPA: Scottish Environment Protection Agency

### Walls below the DPC <sup>5.1.12</sup>

*Also see: Chapters 6.1 and 6.2*

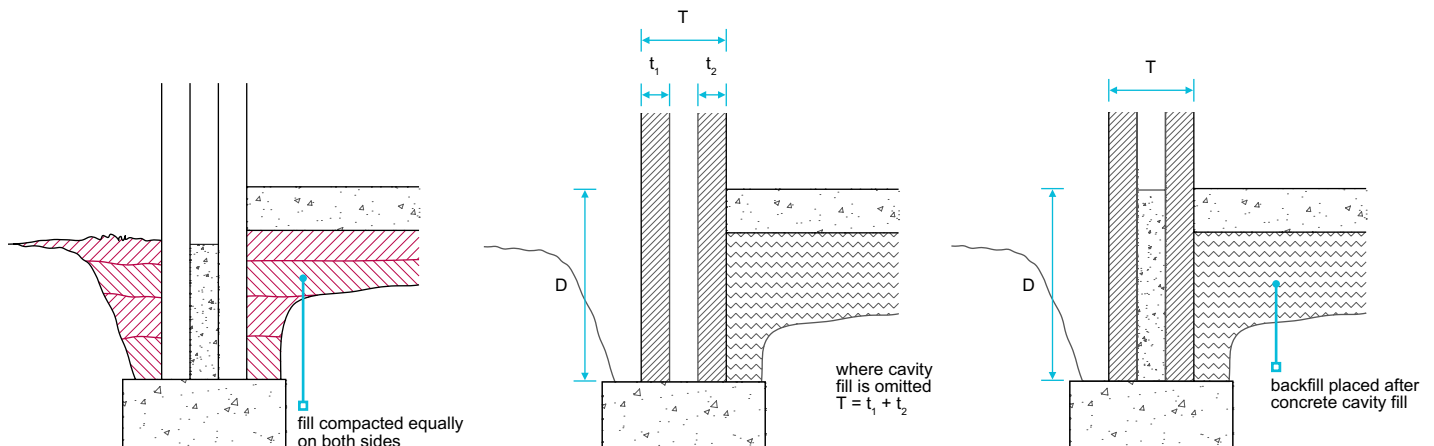
**Substructure and walls below the DPC shall be suitably constructed. Issues to be taken into account include:**

- a) construction of walls acting as temporary retaining walls
- b) concrete cavity fill.

#### Construction of walls acting as temporary retaining walls

Backfill should be placed in layers of equal thickness to both sides of the substructure walls, so that compaction on one side is not more than one layer ahead of the other. Where backfill is placed and compacted on one side of the foundation trench before the other side is backfilled, the wall will be acting as a temporary retaining wall.

In such cases, the wall should either be designed by an engineer in accordance with Technical Requirement R5 or the thickness (T) should be as indicated in Table 2.



**Table 2:** Acceptable D:T of temporary retaining walls

Depth (D) of filled trench	Minimum thickness (T) of wall leaf supporting fill
Up to 1100mm	200mm
1100-1400mm	300mm
1400-1700mm	400mm
1700-2000mm	500mm

This guidance is only applicable to the temporary condition and where problems such as hydrostatic pressure are not present.

### Concrete cavity fill

A minimum 225mm clear cavity below the DPC should be maintained. When specialised foundations are used, including those for timber framed buildings, the minimum clear cavity depth may be reduced to 150mm below the DPC, provided that weep holes and other necessary measures are taken to ensure free drainage.

### Durability <sup>5.1.13</sup>

*Also see: Chapters 4.3, 6.1 and BS EN 1996-1-1*

**Substructure and walls below the DPC shall be capable of supporting their intended loads and, where necessary, be resistant to frost action, sulfates and other harmful or toxic materials. Issues to be taken into account include:**

- a) brickwork
- b) blockwork.

Frost damage occurs on saturated masonry exposed to freezing conditions. Bricks, blocks and mortars located 150mm above and below ground level are the most likely to be damaged by frost.

Masonry walls below the DPC should be designed and constructed as described in Chapter 6.1 'External Masonry Walls'.

Recommendations for the design strength of bricks, masonry blocks and mortars are given in BS EN 1996-1-1.

### Brickwork

Bricks should be of suitable durability, especially in the outer leaf below the DPC, or where they could be frozen when saturated. Bricks used in retaining walls should be suitable for the exposure and climate, as recommended by the manufacturer.

Clay bricks should comply with BS EN 771, which classifies bricks according to their durability designation (F) and to the content of active soluble salts (S).

F0	Not freeze/thaw resistant and should not be used externally
F1	Moderately freeze/thaw resistant
F2	Freeze/thaw resistant
S1	Normal active soluble salts
S2	Low active soluble salts

Generally, bricks are designated to F1,S2 or F1,S1. If in doubt as to suitability, bricks of F2,S2 or F2,S1 should be specified, or the manufacturer consulted and written confirmation obtained in relation to:

- geographical location
- location in the structure.

Calcium silicate bricks for use below DPC should be at least compressive strength class 20.

### Blockwork

Concrete blocks for use below the DPC should meet BS EN 771 and one of the following:

- Minimum density of 1500kg/m<sup>3</sup>
- assessed in accordance with Technical Requirement R3.
- Minimum compressive strength of 7.3N/mm<sup>2</sup>

Where it is necessary to resist sulfate attack and ensure adequate durability, blocks made with sulfate-resisting cement and/or a higher than normal cement content should be used.

Where there is doubt regarding the suitability of the block, particularly where acids or sulfates occur, written confirmation of its suitability should be obtained from the manufacturer in relation to:

- geographical location
- location in the structure.



### Mortar <sup>5.1.14</sup>

*Also see: Chapter 6.1*

**Substructure and walls below DPC level shall use mortar which is suitable for the location and intended use.**

**Issues to be taken into account include:**

- a) mortar mix
- b) sulfate resistance.

#### Mortar mix

Mortar should comply with the design and should take account of the strength, type and location of the masonry. The selection of mortar for use below the DPC should follow the recommendations given in BS EN 1996-1-1.

The use of proprietary mortars and admixtures should:

- account for the type of masonry unit and its location
- only be used in accordance with the manufacturer's recommendations.

For non-clay bricks or blocks, mortar should be used in accordance with the brick manufacturer's recommendations.

#### Sulfate resistance

Sulfate-resisting cement should be used where:

- sulfates are present in the ground, ground water or masonry
- recommended by the brick manufacturer.

In such cases, sulfate-resisting cement to BS 4027 should be used.

### Wall ties <sup>5.1.15</sup>

**Substructure and walls below the DPC shall use wall ties suitable for their intended use.**

Wall ties should comply with BS EN 845 or be assessed in accordance with Technical Requirement R3.

Where cavity insulation batts or slabs start below DPC level, the vertical and horizontal spacing of wall ties should be compatible with the spacing to be used above DPC level.

### Blinding <sup>5.1.16</sup>

**Blinding shall provide a suitable surface for the materials above.**

Infill should be sufficiently blinded to receive the concrete, and DPM where required, using the minimum thickness necessary to give a suitable surface.

Concrete blinding may be needed where voids in the fill could result in loss of fines from the blinding. Where hardcore fill is used, smooth blinding, e.g. sand or other suitable fine material, is essential to avoid puncturing a sheet DPM.

Where the ground floor is to be reinforced, blinding should be firm and even, to give good support for the reinforcement and to maintain the design cover using reinforcement stools, where appropriate.

### Ground floor slab and concrete <sup>5.1.17</sup>

*Also see: Chapter 3.1*

**Ground-bearing floors shall be of adequate strength and durability, and use concrete mixed and reinforced as necessary to support floor loads safely and resist chemical and frost action.**

Ground-bearing concrete floor slabs should be at least 100mm thick, including monolithic screed where appropriate.

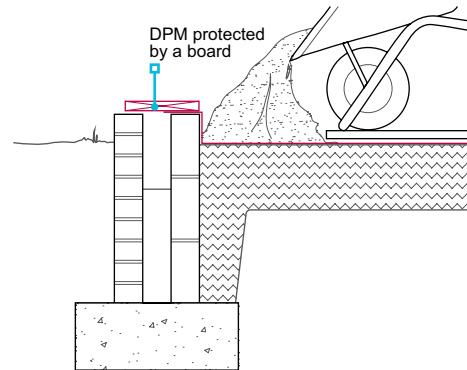
### Laying the ground-bearing floor slab <sup>5.1.18</sup>

Also see: Chapters 3.1 and 9.3

**Ground-bearing floors shall be reasonably level and effectively impervious to moisture.**

All underfloor services and ducts should be installed and tested before concreting, where appropriate.

Care should be taken to ensure that all joints and junctions between DPMS, wall DPCs or tanking in substructure walls are undamaged, especially while the concrete for the ground slab is being poured.



### Damp proof course <sup>5.1.19</sup>

Also see: Chapters 5.4 and 6.1

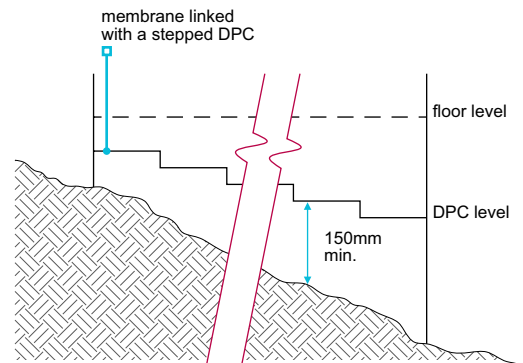
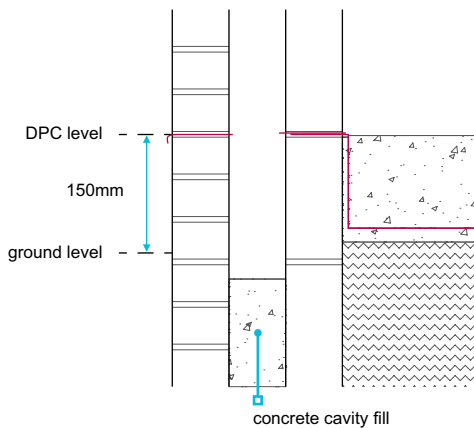
**Damp proof courses shall adequately resist moisture from reaching the inside of the building. Issues to be taken into account include:**

- a) positioning of DPC's
- b) DPC materials.

#### Positioning of DPC's

DPCs should be:

- positioned a minimum of 150mm above finished ground or paving level
- linked with any DPM
- of the correct width and fully bedded
- either welded or lapped by 100mm minimum
- impermeable.



Where homes are 'stepped' on a sloping site, care should be taken to link DPCs and DPMS so that all parts of each home are protected.

#### DPC materials

Acceptable materials for DPCs include:

<b>Bitumen based materials</b>	BS 6398
<b>Polyethylene, (should not be used below copings, in parapets or for tanking)</b>	BS 6515 0.5mm minimum
<b>Proprietary materials</b>	Technical Requirement R3

DPCs and flexible cavity trays should be of the correct dimensions. At complicated junctions, preformed cavity trays of the correct type and shape should be used.

Brick DPCs are only suitable to resist the upward movement of moisture and should:

- consist of two courses of engineering bricks, laid broken bond
- be bedded and jointed in a 1:¼:3, cement:lime:sand, or equivalent, mortar.

### Damp proofing concrete floors <sup>5.1.20</sup>

#### Ground-bearing floors shall resist the passage of moisture to the inside of the home.

Ground-bearing concrete floor slabs should be protected against ground moisture by providing a continuous membrane. The membrane should:

- have sealed laps of at least 300mm wide
- link with wall DPCs to form an impervious barrier to prevent moisture reaching the interior of the dwelling
- take account of possible differential movement.

Care should be taken not to trap moisture when a combination of damp proofing and vapour control layers are used.

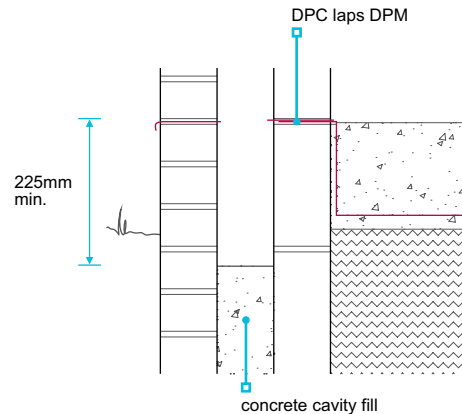
When the membrane is located below the slab, a blinding layer of sand should be provided to fill voids in the hardcore and to minimise the risk of puncturing the membrane.

A clear cavity of at least 225mm below the DPC should be maintained. When specialised foundations are used, including those for timber framed buildings, this depth may be reduced to 150mm below the DPC where weep holes are provided and other necessary measures are taken to ensure that the cavity can drain freely.

Where homes are stepped down a sloping site, the DPCs and DPMs should be linked so that all parts of each home are protected. The guidance in Chapter 5.4 'Waterproofing of basements and other below ground structures' should be followed where steps between floor slabs are greater than 150mm.

Suitable materials for DPM's include:

- 1200 gauge (0.3mm) polyethylene sheet
- minimum 1000 gauge (0.25mm) polyethylene sheet where it complies with Technical Requirement R3
- bitumen sheet to BS 743
- materials that comply with Technical Requirement R3.



### Thermal insulation <sup>5.1.21</sup>

Also see: Chapters 6.1, 9.3 and BRE Report 'Thermal insulation: avoiding risks'

#### Ground-bearing floors and walls below the DPC shall be thermally insulated to comply with building regulations and be suitable for the intended use. Issues to be taken into account include:

- a) floor insulation
- b) wall insulation
- c) cold bridging.

#### Floor insulation

Thermal insulation materials for use below ground-bearing slabs should have:

- appropriate density for the location
- low water absorption.

Insulation to be positioned below both the slab and DPM should be resistant to ground contaminants. The following materials are acceptable for use as insulation:

- expanded polystyrene boards (grade EPS 70) to BS EN 13163
- a proprietary material that complies with Technical Requirement R3.

#### Wall insulation

Cavity insulation materials, super lightweight blocks, blocks with face bonded insulation or integral insulation should be:

- manufactured and used to comply with a British Standard and relevant code of practice, or
- used in compliance with Technical Requirement R3.

The thickness of materials should be suitable for the required level of performance:

<b>England and Wales</b>	<ul style="list-style-type: none"> <li>■ BS 6232 Thermal insulation of cavity walls by filling with blown man-made mineral fibre</li> <li>■ BS 6676 Thermal insulation of cavity walls using man-made mineral fibre batts (slabs)</li> <li>■ BS 5617 for UF foam when permitted and installed by a specialist company registered by BSI in accordance with BS 5618.</li> </ul>
<b>Scotland</b>	<ul style="list-style-type: none"> <li>■ Not permitted to fill the full width of the cavity with any thermal insulants at the time of construction.</li> </ul>
<b>Northern Ireland and the Isle of Man</b>	<ul style="list-style-type: none"> <li>■ Not permitted to fill cavities with pumped thermal insulants at the time of construction.</li> </ul>

### Cold bridging

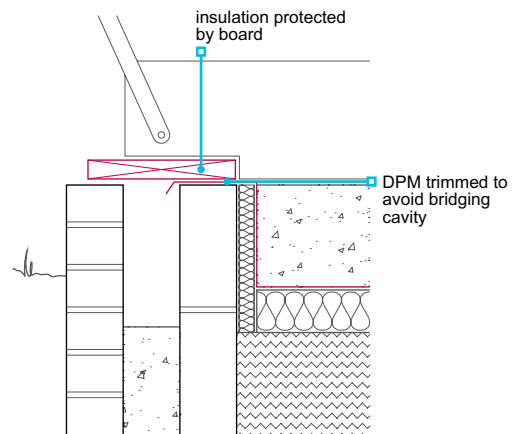
The design should ensure that any risk of cold bridging is minimised, especially at junctions between floors and external walls. Precautions include:

- extending cavity insulation below floor slab level
- linking floor and wall insulation
- providing perimeter insulation to floors
- facing supporting substructure with insulation – where homes are stepped or staggered, the wall forming the step or stagger may require insulation.

### Installation of insulation <sup>5.1.22</sup>

**Installation of thermal insulation shall ensure that the full thermal performance of the floor is achieved.**

Insulation boards should be tightly butted together to maintain insulation continuity. Where the insulation is turned up vertically at the edge of the slab, it should be protected whilst the concrete is being poured and tamped.



### Further information <sup>5.1.23</sup>

- *BRE Special Digest 433.*

# Suspended ground floors

## CHAPTER 5.2

This chapter gives guidance on meeting the Technical Requirements for suspended ground floors including those constructed from:

- in-situ concrete
- precast concrete
- timber joists.

5.2.1	Compliance	01
5.2.2	Provision of information	01
5.2.3	Contaminants	01
5.2.4	Proprietary systems	01
5.2.5	Transfer of loads: concrete floors	01
5.2.6	Reinforced concrete	02
5.2.7	Construction of suspended concrete ground floors	02
5.2.8	Transfer of loads: timber floors	02
5.2.9	Thermal insulation and cold bridging	03
5.2.10	Damp-proofing and ventilation	03
5.2.11	Floor finishes	04
5.2.12	Floor decking	04



Raising Standards. Protecting Homeowners

### Compliance <sup>5.2.1</sup>

*Also see: Chapters 2.1, 4.1, 4.2, 4.5 and 5.1*

#### **Suspended ground floors shall comply with the Technical Requirements.**

Suspended ground floors that comply with the guidance in this chapter will generally be acceptable.

Ground floors should be constructed as suspended floors where:

- the depth of fill exceeds 600mm
- there is shrinkable soil that could be subject to movement (See Chapter 4.2 'Building near trees'), expansive materials or other unstable soils
- the ground has been subject to vibratory improvement
- ground or fill is not suitable to support ground-bearing slabs.

### Provision of information <sup>5.2.2</sup>

#### **Designs and specifications shall be produced in a clearly understandable format, include all relevant information and be distributed to all appropriate personnel.**

Design and specification information should be issued to site supervisors, relevant specialist subcontractors and suppliers, and include the following information:

- All necessary plan dimensions and levels related to identified benchmarks.
- Details of load-bearing walls.
- Minimum bearing dimensions.
- Information on all proposed underground services.
- Points of entry to the building for services.
- Details of trench backfill, infill and void formers.
- Details of junctions between DPM, DPC and tanking.
- Details of underfloor and floor edge insulation and cavity insulation, where relevant.
- Span and direction of structural members.
- Details of non-loadbearing walls.

### Contaminants <sup>5.2.3</sup>

*Also see: Chapter 4.1, BRE Report 211 and Approved Document C1/2/3 Appendix 'Introduction to remedial measures'*

#### **Suspended ground floors shall be designed and constructed to ensure that adequate measures are taken against the adverse effects of ground contaminants, including adequate protection against radon gas.**

Any contaminants in, or above, the ground should be identified to the satisfaction of NHBC, following the guidance given in the appropriate British Standard, and precautions against health hazards caused by contaminants should be taken.

Precautions acceptable to NHBC may be necessary to reduce the entry of radon gas; such conditions should be identified in the site investigation.

### Proprietary systems <sup>5.2.4</sup>

#### **Proprietary suspended flooring systems shall have adequate strength and durability.**

Proprietary concrete flooring systems should be designed in accordance with BS EN 1992-1-1. Where a system incorporates elements which cannot be designed to this standard, e.g. polystyrene infill blocks, the floor should be assessed in accordance with Technical Requirement R3.

### Transfer of loads: concrete floors <sup>5.2.5</sup>

#### **Suspended ground floors shall be designed and constructed to transmit all loads safely to the supporting structure without undue movement. Issues to be taken into account include:**

- a) dead and imposed loads
- b) end bearings.

#### **Dead and imposed loads**

##### **In-situ:**

Loads should be calculated in accordance with BS EN 1991-1-1.

Suspended in-situ concrete ground floors should be designed either:

- by an engineer in accordance with Technical Requirement R5, or
- in accordance with BS 8103-1.

**Precast:**

Loads should be calculated in accordance with BS EN 1991-1-1.

Precast concrete suspended ground floors should be:

- designed by an engineer in accordance with Technical Requirement R5
- proprietary systems which have been assessed in accordance with Technical Requirement R3, or
- chosen from the manufacturer's details which are based on recognised standards and codes of practice.

**End bearings****In-situ:**

Bearings on supporting walls should be designed either:

- by an engineer in accordance with Technical Requirement R5, or
- in accordance with BS 8103-1.

**Precast:**

Bearings on supporting walls should be as recommended by the manufacturer, and in no case less than 90mm.

**Reinforced concrete <sup>5.2.6</sup>**

*Also see: Chapter 3.1*

**Suspended ground floors shall use suitably mixed and reinforced concrete, which will achieve sufficient strength to support floor loads safely and be sufficiently durable to remain unaffected by chemical or frost action.**

Guidance for the specification and use of in-situ concrete, additives and reinforcement is contained in Chapter 3.1 'Concrete and its reinforcement'.

**Construction of suspended concrete ground floors <sup>5.2.7</sup>**

*Also see: Chapter 6.4*

**Suspended ground floors shall be designed and constructed to ensure the safe support of the intended loads and be reasonably level.**

**In-situ:**

Concreting should be carried out in accordance with:

- the design information
- relevant parts of NHBC guidance for concrete, including Chapter 3.1 'Concrete and its reinforcement'.

**Precast:**

Care should be taken to ensure that DPCs are not damaged or displaced. All sitework for precast concrete floors should be carried out in accordance with the manufacturer's recommendations.

**Transfer of loads: timber floors <sup>5.2.8</sup>**

*Also see: Chapters 4.3 and 6.4*

**Timber suspended ground floors, including the decking material, shall be designed and constructed to be suitable for their intended use. Issues to be taken into account include the:**

- a) support of self-weight, dead and imposed loads and limited deflection
- b) safe transmission of loads to the supporting structure
- c) adverse effects of shrinkage and movement.

**Support of self-weight, dead and imposed loads, and limited deflection**

Structural timber grades and sizes should be adequate for the spans and imposed loads. Where trimming is necessary, adequately sized timbers should be used.

**Safe transmission of loads to the supporting structure**

Joist hangers should be suitable for:

- the joist width and depth
- the loading
- the strength of masonry
- providing adequate end bearings to joists.

Sleeper walls should adequately support the floor joists, and joists should be correctly supported at masonry separating walls.

**Shrinkage and movement**

Strutting should be provided where required to limit the twisting of joists.

### Thermal insulation and cold bridging <sup>5.2.9</sup>

*Also see: Chapter 9.3 and BRE report 'Thermal insulation: avoiding risks'*

**Suspended ground floors shall be insulated in accordance with building regulations to minimise thermal transmission through the floor and using materials suitable for the location and intended use.**

Insulation should be installed to ensure that any risk of cold bridging is minimised, especially at junctions between floors and external walls. Cold bridging precautions include:

- extending cavity wall insulation below floor level
- providing perimeter insulation to floors.

Insulation below cast in-situ suspended ground floor slabs should be:

- placed on a suitable, compacted and even substrate
- strong enough to support wet construction loads
- of a material with low water absorption
- compatible with any DPM.
- resistant to ground contaminants

Insulation for timber floors may be either insulation quilt or rigid insulation.

Cavity wall insulation should extend below the floor insulation level.

Insulation for use above suspended concrete floors should be in accordance with Chapter 9.3 'Floor finishes'.

### Damp-proofing and ventilation <sup>5.2.10</sup>

*Also see: Chapters 4.2, 5.1, 5.4, 6.1 and 9.3*

**Suspended ground floors shall be designed and constructed to resist the passage of moisture into the building. Issues to be taken into account include:**

- a) damp-proofing
- b) ventilation.

#### Damp-proofing

Where DPMs are required, they should be linked with any DPCs in the supporting structure, in order to provide continuous protection from moisture from the ground or through the supporting structure.

DPMs should be properly lapped in accordance with Chapter 5.1 'Substructure and ground-bearing floors'.

#### In-situ concrete:

Dampness from the ground and supporting structure should be prevented from reaching the floor by using linked DPMs and DPCs to provide continuous protection.

Where there is a risk of sulfate attack, in-situ or oversite concrete should be protected with polyethylene sheet that is a minimum:

- 1200 gauge (0.3mm), or
- 1000 gauge (0.25mm) if assessed in accordance with Technical Requirement R3.

#### Precast concrete:

Additional damp-proofing may not be necessary where:

- the underfloor void is ventilated and DPCs are provided under bearings of precast floors in accordance with CP 102
- ground below the floor is effectively drained, if excavated below the level of the surrounding ground.

Where proprietary floor systems are used, adequate moisture-resistant membranes should be installed in accordance with the manufacturer's recommendations.

Vapour control layers may be necessary to protect floor finishes, and where used, should be positioned in accordance with the manufacturer's recommendations.

#### Timber ground floors:

Timber used for suspended ground floors should be treated or naturally durable, in accordance with Chapter 3.3 'Timber preservation (natural solid timber)', and the ground below the floor covered with:

- 50mm concrete or fine aggregate on a polyethylene membrane laid on 50mm sand blinding, or
- 100mm concrete.

In Scotland, the deemed-to-satisfy specification of the building regulations should be followed.



## Ventilation

Ventilation should be provided to precast and timber suspended floors. This is generally provided by ventilators on at least two opposite external walls, with air bricks properly ducted in accordance with Chapter 6.1 'External masonry walls'. Where this is not possible, suitable cross ventilation should be provided by a combination of openings and air ducts. Ventilation should not be obtained through a garage.

Sleeper walls and partitions should be constructed with sufficient openings to ensure adequate through ventilation. If necessary, pipe ducts should be incorporated in adjoining solid floors, separating walls or other obstructions. Where underfloor voids adjoin ground bearing floors, ventilation ducts should be installed.

Void ventilation should be provided to whichever gives the greater opening area:

- 1500mm<sup>2</sup> per metre run of external wall
- 500mm<sup>2</sup> per m<sup>2</sup> of floor area.

In the case of timber floors, ventilators should be spaced at no more than 2m centres and within 450mm of the end of any wall.

A minimum ventilation void of 150mm should be provided below the underside of precast concrete and timber suspended floors. On shrinkable soil where heave could take place, a larger void is required to allow for movement according to the volume change potential.

- high volume change potential – 150mm (300mm total void)
- low volume change potential – 50mm (200mm total void).
- medium volume change potential – 100mm (250mm total void)

## Floor finishes <sup>5.2.11</sup>

**Finishes to concrete suspended ground floors shall be protected where necessary, against damp, condensation or spillage.**

Guidance for suitable floor finishes is given in Chapter 9.3 'Floor finishes'. Care should be taken to prevent trapping any water spillage below timber floors.

Other floor decking should be assessed in accordance with Technical Requirement R3 and should be installed in accordance with manufacturers' recommendations.

## Floor decking <sup>5.2.12</sup>

**Floor decking shall be suitable for the intended purpose and be correctly installed.**

Acceptable installation details and materials used for decking are detailed in Chapter 6.4 'Timber and concrete upper floors'.

# Drainage below ground

## CHAPTER 5.3

This chapter gives guidance on meeting the Technical Requirements for foul, surface water and ground water drainage systems.

This chapter does not apply to the adoption of sewers under Section 104 agreement of the Water Industry Act 1991 or the Sewerage (Scotland) Act 1968. For information on standards required for adopted sewers, contact the local sewerage undertaker and other relevant authorities.

5.3.1	Compliance	01
5.3.2	Provision of information	01
5.3.3	Preliminary work	01
5.3.4	Foul and surface water disposal	02
5.3.5	Drainage system performance	03
5.3.6	Ground water drainage	03
5.3.7	Design to avoid damage and blockages	03
5.3.8	Durability	07
5.3.9	Septic tanks and cesspools	08
5.3.10	Septic tanks	09
5.3.11	Surface water soakaways	11
5.3.12	Component requirements	13
5.3.13	Excavation	13
5.3.14	Protection of pipework	14
5.3.15	Laying pipework	15
5.3.16	Protection of work	16
5.3.17	Testing	16



Raising Standards. Protecting Homeowners

### Compliance <sup>5.3.1</sup>

*Also see: Chapter 2.1*

#### Drainage systems shall comply with the Technical Requirements.

Below ground drainage that complies with the guidance in this chapter will generally be acceptable.

All drainage schemes require the approval of the building control authority. Local sewerage undertakers may impose additional requirements and restrictions. Both should be consulted early, especially where the drainage system is to be adopted under a Section 104 agreement of the Water Industry Act 1991 or Sewerage (Scotland) Act 1968. The system may need to be inspected and tested by the sewerage undertaker, as well as by the local authority, building control authority and NHBC.

Satisfactory outfall disposal is essential where a septic tank is installed. In England and Wales, Environment Agency consent may be required to discharge effluent from a septic tank. In Northern Ireland, the NIEA should approve proposals; in Scotland, the local authority and, where appropriate, the river purification authority should approve proposals.

Ground conditions may preclude the use of septic tanks in some locations. In all cases, NHBC will require evidence of a satisfactory percolation test where a septic tank drainage system is being installed.

For surface water discharge into a watercourse, the permission of the Environment Agency is required in England and Wales. A 'consent to discharge' is required from the Department of the Environment in Northern Ireland. In Scotland, the local authority and, where appropriate, the river purification authorities should be consulted.

In all cases:

- relevant local authorities should be consulted and appropriate permissions sought before sitework begins
- NHBC will require evidence of a satisfactory percolation test where a septic tank drainage system is being installed.

**Table 1:** Guide to relevant authority

	Septic tank discharge	Surface water discharge into a watercourse
England and Wales	Environment Agency DEFRA	
Northern Ireland	Northern Ireland Environment Agency	
Scotland	Local authority River purification authority	Local authority River purification authority Scottish Environmental Protection Agency

### Provision of information <sup>5.3.2</sup>

#### Designs and specifications shall be produced in a clearly understandable format, include all relevant information and be distributed to all appropriate personnel.

Design and specification information should be issued to site supervisors, relevant specialist subcontractors and suppliers, and include the following information:

- Proposed drain layout.
- Invert levels and locations of existing sewers.
- Junctions.
- Ground floor levels of homes.
- External finished levels.
- Inspection and access points.
- Method of disposal of both foul and surface water.
- Position of any septic tank or cesspool in relation to adjacent buildings.
- Results of percolation tests where treated effluent disposal is through field drains.
- Length of field drains and their layout (including details of trench width as this is critical to the functioning of the system).
- Depth of field drains.
- Details of drains or sewers intended for adoption.

### Preliminary work <sup>5.3.3</sup>

#### Drainage systems shall be checked on site to ensure that the design can be achieved.

Check that the following are as specified in the design:

- invert levels and locations of existing sewers
- external finished levels.
- ground floor levels of homes

Percolation tests should be verified where treated effluent disposal is through field drains. The length of any field drains specified in the design should be accommodated within the site boundaries.

**Foul and surface water disposal** <sup>5.3.4</sup>

*Also see: BS EN 752, Clause 5.3.11 and BRE Digest 365*

**Drainage systems shall be designed in accordance with relevant codes and standards to convey foul effluents and surface water satisfactorily to an appropriate outfall. Issues to be taken into account include:**

- a) connections to sewers
- b) connections to surface water disposal systems
- c) rights of connection to disposal systems
- d) compatibility with other systems
- e) capacity of private sewers
- f) treatment plants for more than one home.

**Connections to sewers**

Connections to public sewers require the agreement of the responsible authority, which should be consulted as to the type and position of the connection.

Connections to private sewers require the agreement of the owners of the sewer. This should be obtained as part of the design process. Where the private sewer subsequently discharges into a public sewer, the local sewerage undertaker should be notified of the proposal.

**Connections to surface water disposal systems**

Surface water drainage is generally required to be separated from foul water drainage. Where permitted, surface water may be discharged into the main public surface water drains or directly into natural watercourses, ponds or soakaways, as appropriate. Surface water should not discharge to:

- septic tanks
- cesspools
- separate foul sewers.

For large or complicated homes, the volume of surface water to be disposed should be calculated in accordance with BS 6367.

**Rights of connection to disposal systems**

A legal right must exist when connecting drains to an outfall.

**Compatibility with other systems**

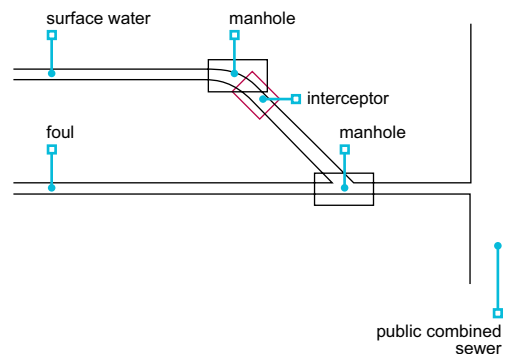
The drainage system should be compatible with the main sewerage system:

- with separate systems for foul water and surface water
- with separate systems where foul water is connected to the main sewer, while surface water disposal is by soakaways or other suitable means, or
- as a combined system.

Where the sewerage undertaker permits surface water drains to be connected to a foul water system:

- an interceptor should be installed on the surface water side of the foul sewer junction, or
- trapped gullies should be used.

Where ground water drains are connected to surface water drains, there should be a silt trap on the ground water side of the junction.



**Capacity of private sewers**

Private drainage systems should be:

- in accordance with BS EN 752
- sufficient to cope with the intended capacity.

Where an existing private drainage system is to be extended, or where the capacity is to be increased, sufficient investigation, measurement and calculation should be undertaken to ensure that all parts of the private system are of adequate capacity.

**Treatment plants for more than one home**

Small sewage treatment works for more than one home should be designed in accordance with BS 6297.

Discharge from the waste water treatment plant should be:

- sited at least 10m away from water courses and homes
- designed by a suitably qualified engineer.

### Drainage system performance <sup>5.3.5</sup>

*Also see: Chapter 4.1, 8.1, BRE Report 211 and BRE Report 212*

**Drainage shall be suitably located and prevent health hazards. Issues to be taken into account include:**

- |  |   |
|--|---|
| a) ventilation of drainage systems       | c) siting of septic tanks and cesspools |
| b) prevention of gases entering the home | d) pumped systems.                      |

#### Ventilation of drainage systems

Ventilation of drains is normally achieved by ventilating discharge stacks.

Air admittance valves which comply with Technical Requirement R3 may be used in some homes to prevent trap seal siphonage. An open vent is generally required at the head of common drainage systems, and where the discharge pipe is the only vent for a septic tank or cesspool.

#### Prevention of gases entering the home

Where special precautions are necessary (e.g. sealing drains where they enter the building) to reduce the entry of gases such as radon or landfill gas, such precautions should be acceptable to NHBC.

#### Siting of septic tanks and cesspools

Septic tanks and cesspools should be:

- |                              |  |
|------------------------------|--|
| ■ a minimum of 7m from homes | ■ a maximum of 30m from vehicular access to permit emptying. |
|------------------------------|--|

In Scotland, a minimum distance of 5m from homes and boundaries is acceptable for septic tanks.

#### Pumped systems

Where a gravity system is not possible, pumped systems may have to be used and should be designed in accordance with BS EN 752 and BS 6297. The installation should include:

- |  |                               |
|--|-------------------------------|
| ■ a holding tank of sufficient volume to contain 24 hours of domestic effluent based on 120L/150L per head per day | ■ suitable equipment housing. |
| ■ a suitable warning system providing visual and/or audible signals to indicate malfunction                        |                               |

### Ground water drainage <sup>5.3.6</sup>

**Ground water drainage shall convey excess ground water to a suitable outfall. Issues to be taken into account include:**

- layout of pipes
- pipe construction.

#### Layout of pipes

Where ground water drainage is required, depending on the site contours and ground conditions, it may be designed as:

- |                        |                       |
|------------------------|-----------------------|
| ■ a natural system     | ■ a fan-shaped system |
| ■ a herringbone system | ■ a moat system.      |
| ■ a grid system        |                       |

#### Pipe construction

Pipe perforations should be holes or slots to suit the nature of the ground.

Ground water drain systems connected to foul, surface water or combined drains should discharge into the drain through a catchpit. Where suitable, ground water drainage may discharge into a soakaway, preferably through a catchpit or into a watercourse.

### Design to avoid damage and blockages <sup>5.3.7</sup>

*Also see: Chapter 4.2*

**Drainage systems shall minimise the risk of damage and blockage. Issues to be taken into account include:**

- |                     |                                    |
|---------------------|------------------------------------|
| a) ground stability | e) access and connections          |
| b) pipe runs        | f) drainage covers and gully grids |
| c) pipe sizes       | g) ground water                    |
| d) gradients        | h) flooding.                       |

### Ground stability

Proper allowance should be made for ground movement.

Pipes should have flexible joints and additional precautions taken to prevent leakage where required. Where ground movement could be significant, for example in made-up ground or clay soils, the following issues should be taken into account:

- the use of flexible pipes and flexible joints
- design gradients that are steeper than the minimum requirements for flow rate and pipe size
- a support system designed by an engineer in accordance with Technical Requirement R5
- conditions where ground movement is likely to adversely affect the drain.

In non-uniform or saturated soils where movement at the trench bottom can be expected, soft spots should be removed and replaced with suitable material. Immediately after excavation, the protective blinding should be placed in the trench bottom.

### Pipe runs

Pipe runs should be designed to maintain a self-cleansing velocity (0.7 m/s). They should be as straight as practicable with minimal changes of direction. Bends should only occur in, or next to, inspection chambers and manhole covers. Curves should be slight so that blocked pipes can be cleared.

### Pipe sizes

Pipe sizes should be designed for the maximum peak load in accordance with BS EN 752.

Ground water drains and soakaways should be designed with sufficient capacity for normal weather conditions.

### Gradients

Design gradients should:

- be as even as practicable
- where flows are less than 1.0L/second, gradients for 100mm diameter pipes should not be flatter than 1:40
- where peak flows exceed 1.0L/second, the gradients in Table 2 may be used:

**Table 2:** Minimum gradients

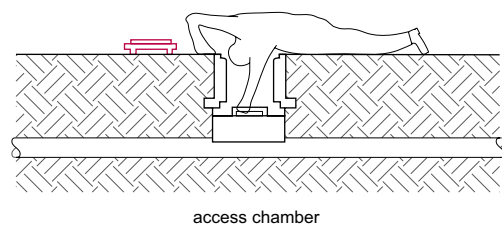
Pipe diameter (mm)	Minimum gradient
100	1:80
150	1:150

Where peak flows are greater than 1.0L/second, 100mm pipes should serve a minimum of one WC and 150mm pipes should serve a minimum of five.

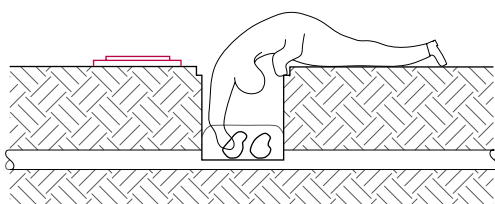
### Access and connections

To ensure that every length of drain can be rodded, the design should include appropriately located access points, such as:

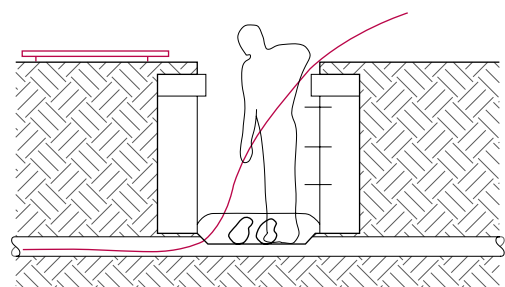
- rodding eyes
- access chambers
- inspection chambers
- manholes.



access chamber



inspection chamber



manhole

All access points should be located as shown in the design information and should:

- be accessible for rodding and cleaning
- not cross boundaries or kerb lines.

Inspection chambers and manholes should:

- be of sufficient size for the depth of invert, and
- the invert depth for the fitting or chamber should not exceeded those given in Table 3.

**Table 3:** Minimum dimensions for access fittings and chambers

Type	Depth to invert from cover level (m)	Internal sizes		Cover sizes		
		Length x width (mm x mm)	Circular (mm)	Length x width (mm x mm)	Circular (mm)	
Rodding eye		As drain but min. 100			Same size as pipework <sup>(1)</sup>	
Small access fitting	150 dia. 150 x 100	0.6 or less, except where situated in a chamber	150 x 100	150	150 x 100 <sup>(1)</sup>	Same size as access fitting
Large access fitting	225 x 100		225 x 100	225	225 x 100 <sup>(1)</sup>	Same size as access fitting
Shallow inspection chamber	0.6 or less 1.2 or less	225 x 100 450 x 450	190 <sup>(2)</sup> 450	– 450	– Min. 430 x 430	190 <sup>(1)</sup> 430
Deep inspection chamber	Greater than 1.2	450 x 450	450	Max. 300 x 300 <sup>(3)</sup>	Access restricted to max. 350 <sup>(3)</sup>	

Notes

- 1 The clear opening may be reduced by 20mm in order to provide further support for the cover and frame.
- 2 Drains up to 150mm.
- 3 A larger clear opening cover may be used in conjunction with restricted access. The size is restricted for health and safety reasons to deter entry.

**Table 4:** Minimum dimension for manholes

Type	Size of largest pipe (DN) (mm)	Minimum internal dimensions <sup>(1)</sup>		Min. clear opening size <sup>(1)</sup>	
		Rectangular length and width (mm)	Circular diameter (mm)	Rectangular length and width (mm)	Circular diameter (mm)
Manhole up to 1.5m deep to soffit	Equal to or less than 150	750 x 675 <sup>(7)</sup>	1000 <sup>(7)</sup>	750 x 675 <sup>(2)</sup>	NA <sup>(3)</sup>
	225	1200 x 675	1200	1200 x 675 <sup>(2)</sup>	
	300	1200 x 750	1200		
	Greater than 300	1800 x (DN+450)	The larger of 1800 or (DN+450)		
Manhole greater than 1.5m deep to soffit	Equal to or less than 225	1200 x 1000	1200	600 x 600	600
	300	1200 x 1075	1200		
	375-450	1350 x 1225	1200		
	Greater than 450	1800 x (DN+775)	The larger of 1800 or (DN+775)		
Manhole shaft <sup>(4)</sup> greater than 3.0m deep to soffit pipe	Steps <sup>(5)</sup>	1050 x 800	1050	600 x 600	600
	Winch <sup>(6)</sup>	900 x 800	900	600 x 600	600
	Ladder <sup>(5)</sup>	1200 x 800	1200		

Notes

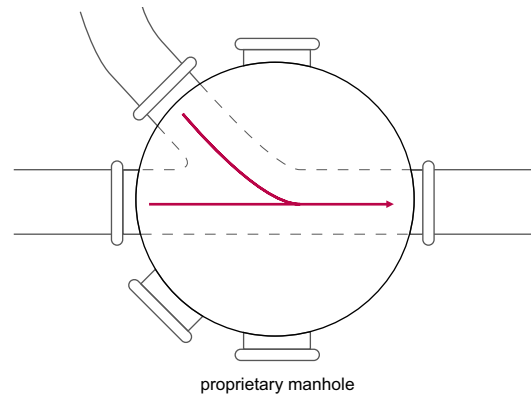
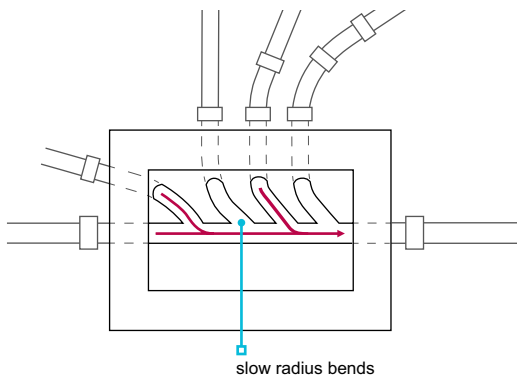
- 1 Larger sizes may be required for manholes on bends or where there are junctions.
- 2 May be reduced to 600 x 600 where required by highway loading restrictions and subject to a safe system of work being specified.
- 3 Not applicable due to working space needed.
- 4 Minimum height of chamber in shafted manhole 2m from benching to underside of reducing slab.
- 5 Minimum clear space between ladder or steps and the opposite face of the shaft should be approximately 900mm.
- 6 Winch only; no steps or ladders, permanent or removable.
- 7 The minimum size of any manhole serving a sewer, i.e. any drain serving more than one home, should be 1200mm x 675mm rectangular or 1200mm diameter.
- 8 Tables 3 & 4 have been reproduced from Tables 11 and 12 of Approved Document H by permission of HMSO.

Inspection chambers and manholes may be one of the following types:

- Open, half-round section channel with suitable benching.
- Closed access, where covers have to be removed to gain access to the pipe.

Side branches to inspection chambers and manholes should discharge into the main channel no higher than half pipe level.

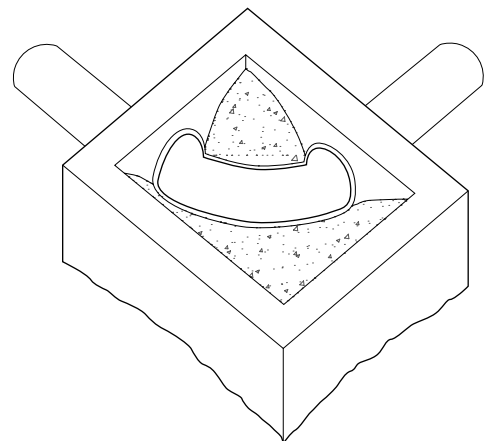
Connections should be made obliquely in the direction of flow.



**Traditional construction**

The minimum specification for traditional manholes and inspection chambers is as follows:

<b>Base</b>	Minimum 100mm concrete.
<b>Walls</b>	Brick, blockwork or concrete should be appropriate for the ground conditions. 100mm minimum thickness is suitable for depths up to 0.9m where no vehicular traffic loads are encountered and there is no ground water pressure. Elsewhere, 200mm minimum thickness should be provided.
<b>Rendering</b>	Where required, rendering should be applied to the external faces of the wall.
<b>Benching</b>	Benching should be steel trowelled to provide: <ul style="list-style-type: none"> <li>■ a smooth finish</li> <li>■ rounded corners</li> <li>■ a fall of not less than 1:12.</li> </ul>



Clay bricks for manholes should comply with BS EN 771 and:

- be of low active soluble salt content
- have a minimum compressive strength of 48N/mm<sup>2</sup>.

Engineering bricks are also suitable.

Concrete bricks for manholes should:

- comply with BS EN 771
- have a minimum crushing strength of 48N/mm<sup>2</sup> with a minimum cement content of 350kg/m<sup>3</sup> for foul drainage.

Calcium silicate bricks should comprise strength class 20 or above for foul drainage situations.

**Proprietary systems**

Proprietary systems should be installed in accordance with manufacturer's instructions.

Proprietary manholes should not be used at a depth greater than the manufacturers' instructions.

Adaptors, couplers and sealing rings should be:

- installed correctly and in accordance with the manufacturers' instructions
- treated using the lubricants and solvents specified.

**Drainage covers and gully grids**

Manhole covers and gully grids should be of the correct type for the proposed location in accordance with Tables 5 and 5a.

Manhole covers used within buildings should be airtight and mechanically secured. Covers used for septic tanks, cesspits and settlement tanks should be lockable.



Manholes should be constructed or installed at the correct level so that the covers will align with the adjacent ground. Gullies should be adequately:

- bedded
- set level
- square and kerbed.

**Table 5:** Type of covering and grid required for inspection and manhole covers and frames

<b>Group 1</b>	Areas which can only be used by pedestrians and cyclists.
<b>Group 2</b>	Footways, pedestrian areas and comparable areas, car parks or car parking decks.
<b>Group 3</b>	For gully tops installed in the area of kerbside channels of roads which when measured from the kerb edge, extend a maximum of 0.5m into the carriageway and a maximum of 0.2m into the footway.
<b>Group 4</b>	Carriageways of roads, including pedestrian streets, hard shoulders and parking areas, and suitable for all types of road vehicles.

Proprietary items, e.g. covers to plastic manholes, should be in accordance with manufacturers' recommendations.

**Table 5a:** Gully grids in carriageways

<b>Grade B</b>	For use in carriageways of roads with cars and slow-moving normal commercial vehicles.
<b>Grade A class 2</b>	For use in carriageways of roads.
<b>Grade A class 1</b>	For use in carriageways of roads (gully grids of permanent non-rock design).

### Ground water

Foul and surface water drainage systems should prevent the ingress of ground water.

### Flooding

Where there is a risk of flooding, the advice of the relevant river authority should be followed.

### Durability <sup>5.3.8</sup>

*Also see: Chapter 3.1 and 6.1*

**Drainage systems shall be adequately durable and protected against damage. Issues to be taken into account include:**

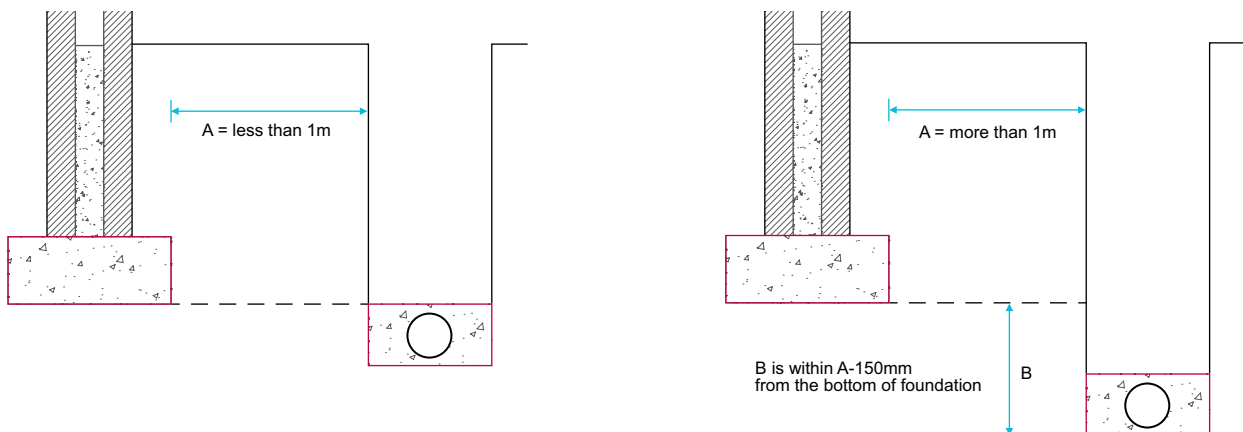
- |  |  |
|--|--|
| a) loads from foundations                | d) drainage under buildings              |
| b) bedding of pipes                      | e) chemicals in ground and ground water. |
| c) loads from overlying fill and traffic |  |

### Loads from foundations

Drains should be located so that foundation loads are not transmitted to pipes. Where drainage trenches are near foundations:

- foundation bottoms should be lower than adjacent trenches, or
- the drain should be re-routed to increase separation.

Where the bottom of a drainage trench is below foundation level, the trench should be filled with concrete to a suitable level.



### Bedding of pipes

Bedding should be in accordance with Clause 5.3.15.

### Loads from overlying fill and traffic

Special protection may be required where pipes are near the ground surface or where they could be damaged by the weight of backfill or traffic load from above.

For flexible pipes, and where greater safety is needed, the bedding class and grading of backfill should comply with BS EN 13242, BS 5955 and BS EN 752.

When using proprietary systems assessed in accordance with Technical Requirement R3, pipes should be supported accordingly.

### Drainage under buildings

Pipework support should take account of the ground conditions and ensure that the drainage is not adversely affected by ground movement.

Pipework under suspended floors should not be supported on ground or fill that is susceptible to movement without adequate provision being made to:

- maintain minimum design gradients
- protect against leakage.
- protect against backfall

Where drains are located beneath raft foundations or where ground movement is likely, the design of the pipework and support system should be carried out by a suitably qualified engineer in accordance with Technical Requirement R5.

See Clause 4.3.14 for 'Pipework passing through substructure walls'.

### Chemicals in ground and ground water

Where the ground or ground water contains sulfates, concrete and masonry work may require special precautions.

## Septic tank and cesspools <sup>5.3.9</sup>

**Septic tanks and cesspools shall be correctly installed and be suitable for their intended use. Issues to be taken into account include:**

- |                           |   |
|---------------------------|---|
| a) capacity               | c) permeability of septic tanks and cesspools |
| b) access and ventilation | d) connections to septic tanks and cesspools. |

A septic tank is a form of treatment plant and requires a suitable outfall for treated effluent discharge, which is agreed with the relevant authority.

A cesspool is a tank which stores effluent and has to be emptied periodically.

### Capacity

The capacity of the septic tank should be based on the number of people it will serve, using the formula:  $C = 180P + 2000$

C = Capacity of tank in litres. Minimum 2700L.

P = Design population/potential occupancy. Minimum four occupants.

Cesspools are required to be at least 18m<sup>3</sup> capacity. A 45-day holding capacity calculated at 150 litres/head/day should be provided.

### Access and ventilation

Septic tanks and cesspools should:

- be covered and ventilated
- be provided with access points for inspection, emptying, de-sludging and cleaning
- have the access points with lockable covers and no dimension less than 600mm.

The inlet and outlet of a septic tank should be provided with access for inspection. The inlet of a cesspool should be provided with access for inspection. Cesspools should have no openings except the inlet, the vent and the inspection access.

### Permeability of septic tanks and cesspools

Septic tanks and cesspools should be impermeable to their contents and to subsoil water. They should be constructed of brickwork, concrete, glass reinforced concrete, glass reinforced plastics or steel.

Brickwork should be of engineering bricks, laid in cement mortar at least 220mm thick. In-situ concrete should be at least 150mm thick.

### Connections to septic tanks and cesspools

The entry flow velocity should be restricted to reduce disturbance in the tank. Where the drain into the septic tank is less than 150mm in diameter; it should have a gradient no steeper than 1:50 for at least 12m.

Rodding and cleaning facilities should be provided at the connection with the tank.

### Septic tanks <sup>5.3.10</sup>

**Septic tanks shall have suitable drainage connections. Issues to be taken into account include:**

- |                               |                 |
|-------------------------------|-----------------|
| a) outfall                    | d) field drains |
| b) flow velocity              | e) underdrains. |
| c) soakaways for septic tanks |                 |

### Outfall

The designer should ensure at an early stage that consent for discharge will be given, or select an alternative method of drainage. Certain locations and ground conditions may preclude the use of septic tanks. Septic tank sewage systems should have:

- satisfactory outfall disposal
- placement that accounts for topography and ensures that water is drained away from the building.

Where a septic tank drainage system is to be installed, NHBC requires:

- evidence of a satisfactory percolation test
- copies of relevant consents and approvals before work commences.

### Flow velocity

A dip pipe should be provided with:

- the top limb rising above scum level , and
- the bottom limb extending about 450mm below top water level.

### Soakaways for septic tanks

#### Soakaways in porous subsoils

A soakaway may be used where the outfall from a septic tank is to discharge to a porous subsoil at a level above that of the winter water table. Soakaway constructions generally consist of an excavation filled with brick bats or other large pieces of inert material, or unfilled but lined, e.g. with dry laid brickwork or precast concrete (porous or perforated) rings, from which the effluent may percolate into the surrounding ground. Proprietary septic tanks should be assessed in accordance with Technical Requirement R3.

Soakaways which are not filled should be covered by a slab incorporating an inspection cover.

The size of the soakaway should be determined as described in this chapter and the area of the bottom of the soakaway should equal the area of trench bottom in Chart 1 below.

Where the porous strata is overlaid by less permeable subsoil, a borehole may be permitted by the appropriate authority.

#### Soakaways in less porous subsoils

In less porous subsoils, a sub-surface irrigation system may be used, which should be designed:

- using approved means to determine the percolation rate
- according to the area of sub-surface drainage from which the length of land drain can be found, determined by the following procedure.

#### Percolation test procedure for septic tanks:

<b>Step 1</b>	Excavate a hole 300mm square and 250mm deep below the proposed invert level of the land drain.
<b>Step 2</b>	Fill with water to depth of 250mm. As an aid, mark a stick 250mm from one end, place in the hole and fill to the mark. Allow the water to drain away overnight.
<b>Step 3</b>	Refill to a depth of at least 250mm and note the time taken (in seconds) to drain away completely.
<b>Step 4</b>	Repeat the exercise two more times and calculate the average of the three results, as follows: $\text{percolation value (s)} = \frac{\text{time to drain away (seconds)}}{\text{depth of water (mm)}}$

The results of the percolation test should be used in accordance with Table 6 to determine a suitable method of drainage.

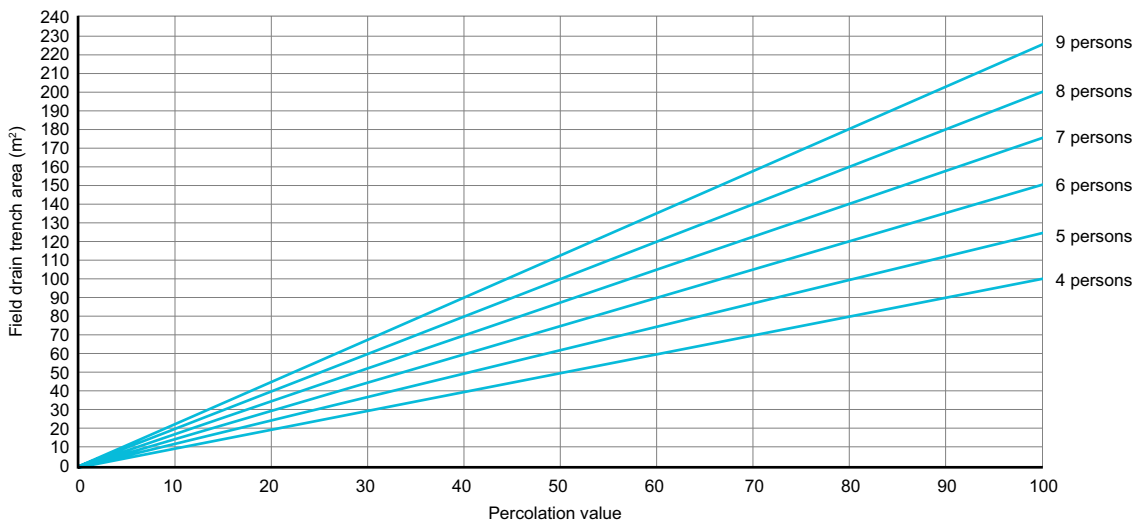
**Table 6:** Suitable methods of drainage

Percolation value (s)	Suitability for less porous subsoils
Up to 100	Chart 1 to determine the field drain trench area. Chart 2 to determine the pipe length to provide this area.
100 to 140	As above, but underdrains are also necessary.
Over 140	The soil is unsuitable for field drains.

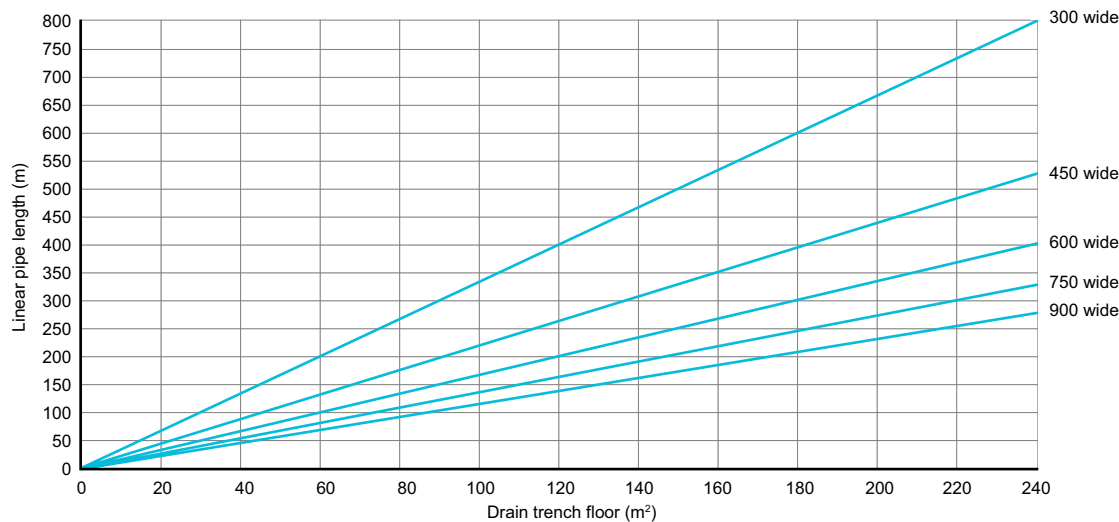
**Table 7:** Capacity based on potential occupancy

Number of persons/bed spaces	Minimum capacity (litres)
< 4	2700
4	2720
5	2900
6	3080
7	3260
8	3440
9	3620
10	3800

**Chart 1:** Field drains trench area



**Chart 2:** Field pipe length



### Field drains

Field drains should be:

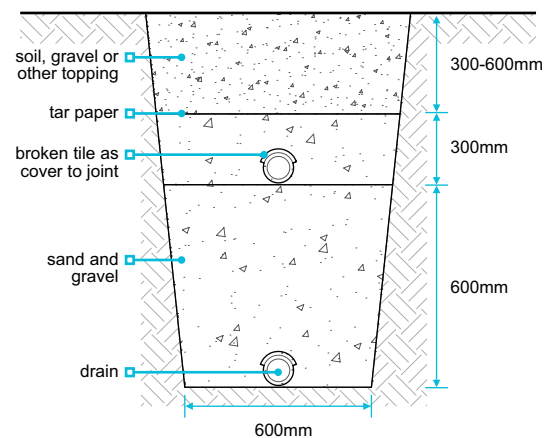
- sited according to topography, ensuring that water is drained away from the building
- formed with perforated pipe, laid at least 500mm below the surface
- laid in trenches with a uniform gradient less than 1:200 with undisturbed ground 2m wide between trenches and at least 8m from any building and 10m from any water course
- laid on a 150mm bed of clinker, clean gravel or broken stone (20mm–50mm grade) and trenches filled to a level 50mm above the pipe and covered with strips of plastic material to prevent entry of silt
- backfilled with as dug material.

Where the level of the water table is expected to rise in the winter months to within 1m of the field drain invert, it is not acceptable to use subsurface irrigation.

### Underdrains

Where underdrains are necessary, drainage trenches should be constructed a minimum of 600mm deeper than the pipe level specified in the design.

The lower part of the drainage trenches should be filled with pea gravel. A second system of drainage pipes should be laid on the bottom of the trenches to convey surplus drainage to an outfall in a surface ditch or watercourse.



### Surface water soakaways <sup>5.3.11</sup>

Also see: BRE Digest 365

**Soakaway drainage shall be sited and constructed to provide adequate short term storage for surface water and adequate percolation into the surrounding ground. Issues to be taken into account include:**

- a) soakaway location
- b) soakaway design.

#### Soakaway location

Soakaways should be:

- built on land lower than, or sloping away from, buildings
- sited at least 5m from the foundations of a building
- sited to take account of topography, ensuring that water is drained away from the building
- in soil of low permeability, only be provided where no alternative system is available.

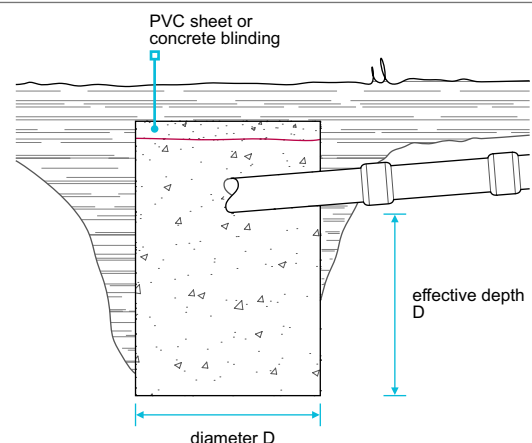
#### Soakaway design

NHBC may require a percolation test for a soakaway, especially where there is:

- doubt about the ground,
- a large quantity of run-off into the soakaway which may swamp the ground.

Where the ground is free draining and granular, a test may not be necessary.

In soil, chalk and fill material subject to modification or instability, the advice of a specialist geotechnologist should be sought regarding the siting and suitability of soakaways.



**Small soakaways**

Small soakaways are holes filled with granular material, e.g. broken brick, crushed rock or gravel, with particle size 10mm to 150mm. PVC sheet or concrete blinding should be laid over the fill to prevent topsoil being washed down into the soakaway.

**Large soakaways**

Large soakaways consist of a pit lined with dry jointed or honeycomb brickwork. Alternatively, precast perforated concrete rings or segments may be laid dry and surrounded with granular material. The volume of large soakaways should be calculated to ensure suitable capacity.

**Percolation test procedure for surface water soakaway**

The rate at which water will disperse into the ground depends on the permeability of the ground, which varies with soil type. The percolation test provides an assessment of how the ground drains.

As the test hole can be used as part of a soakaway, it should be:

- dug in a place that could be used as a soakaway
- to the same depth as the proposed drain.
- at least 5m from the foundations of a building

**Percolation test procedure for surface water soakaways**

<b>Step 1</b>	Bore a hole 150mm in diameter with an auger, to a depth of one metre.
<b>Step 2</b>	Fill with water to depth of 300mm. As an aid, mark a stick 300mm from one end, place in the hole and fill up to the mark. It takes approximately 5.5 litres to fill a volume of this size.
<b>Step 3</b>	Observe the time taken in minutes for the water to soak away.
<b>Step 4</b>	Where possible, the test should be repeated and the average time used.
<b>Step 5</b>	A second group of tests are carried out after the hole has been bored out to a depth of two metres, still using a 300mm depth of water.
<b>Step 6</b>	Where the soil appears to become more permeable with depth, it may be useful to deepen and retest the bore in one-metre stages.

**Design of soakaway**

The relationship between the diameter or effective depth required for a soakaway, to suit a given collection area, e.g. roof or paved surface, and the average time (T) resulting from the test is shown in the graph below.

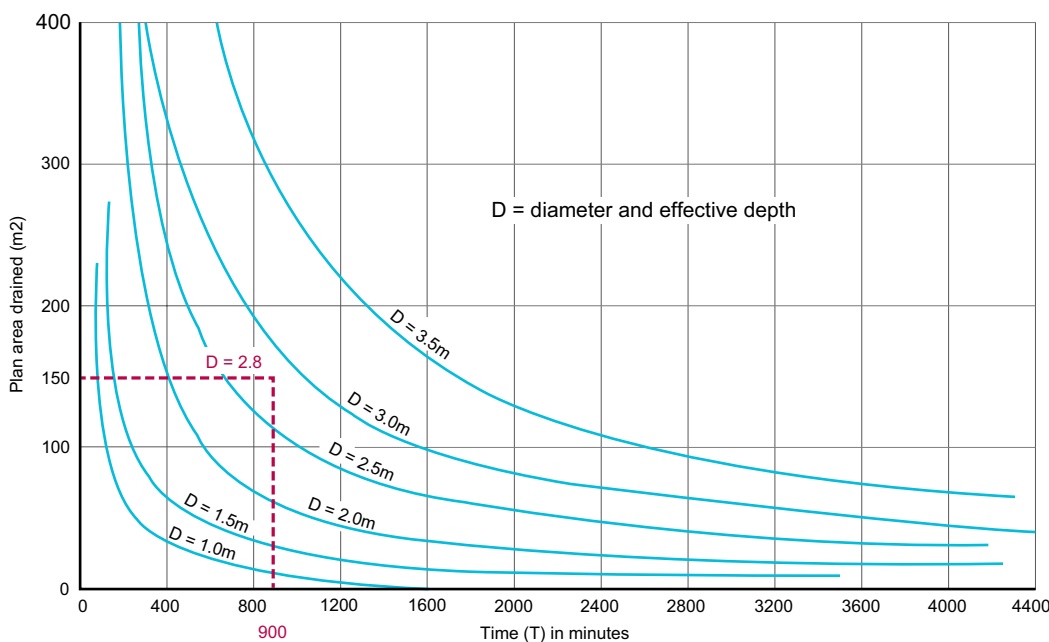
The diameter and effective depth below invert level are assumed to be the same dimension (D).

**Example**

Test time (T) = 900 minutes

Plan area to drain = 150m<sup>2</sup>

From the graph below, the diameter and effective depth of the soakaway (D) are both 2.8m.



Where the ground is of low permeability; dig separate soakaways to drain smaller but distinct parts, for example:

- one side of a roof to one soakaway
- the driveway or yard to a third soakaway.
- the other side to a second soakaway

Where the permeability of the ground increases with depth; tests in the deepened trial holes will give shorter percolation times. It may be more cost effective to build a smaller soakaway at a greater depth below the surface.

### Component requirements <sup>5.3.12</sup>

**Drainage systems shall be constructed with materials that ensure satisfactory service over the life of the system.**

Components in accordance with the following standards will generally be acceptable:

<b>BS 65</b>	Vitrified clay pipes, fittings, joints and ducts, including perforated pipes.
<b>BS 437</b>	Cast iron spigots, socket drainpipes and fittings.
<b>BS 1247</b>	Manhole step irons.
<b>BS 4660</b>	Unplasticised PVC underground drain pipes and fittings.
<b>BS 4962</b>	Plastics pipes for use as light duty subsoil drains.
<b>BS 5911</b>	Precast concrete pipes, fittings and ancillary products.
<b>BS 5955</b>	Plastics pipework including thermoplastic materials.
<b>BS 6087</b>	Flexible joints for cast iron drainpipes and fittings (BS 437) and for cast iron soil, waste and ventilating pipes and fittings (BS 416).
<b>BS DD 76</b>	Draft for development, including precast concrete pipes of composite construction.
<b>BS EN 588</b>	Fibre cement pipes for sewers and drains.
<b>BS EN 124</b>	Gully tops and manhole tops for vehicular and pedestrian areas.
<b>BS EN 295</b>	Vitrified clay pipes, fittings and pipe joints for drains and sewers.
<b>BS EN 1401-1</b>	Plastics piping systems for non-pressure underground drainage and sewerage – Unplasticised poly (vinyl chloride) (PVC-U).

### Excavation <sup>5.3.13</sup>

**Excavations shall ensure that the invert levels and gradients required by the design are achieved. Issues to be taken into account include:**

- a) setting out dimensions
- b) depth of trenches
- c) width of trenches.

#### Setting out dimensions

When setting out:

- discrepancies in dimensions, and ground conditions which require design modification, should be reported to the designer
- drain runs and depths should be set out from benchmarks previously checked and verified
- resulting variations should be recorded and distributed to all concerned.

#### Depth of trenches

Excavate to the depths specified in the design.

Where any trench is excavated lower than the designed bottom level, it should be refilled to the designed level.

Fill material should be:

- granular material, or
- concrete mix GEN1 or ST ½, (not for field drains).

Hard spots should be undercut and removed so that local stress points under pipes are avoided. Soft spots should be filled with suitable well-compacted material.

#### Width of trenches

Trenches should be as narrow as possible within working limits and allow a minimum 150mm working space on each side of the pipe.

**Protection of pipework** 5.3.14

Also see: Chapter 4.3 and 5.1

Drainage systems shall have pipework adequately protected against damage. Issues to be taken into account include:

- a) pipes passing through substructure walls
- b) pipework under finishes
- c) movement joints.

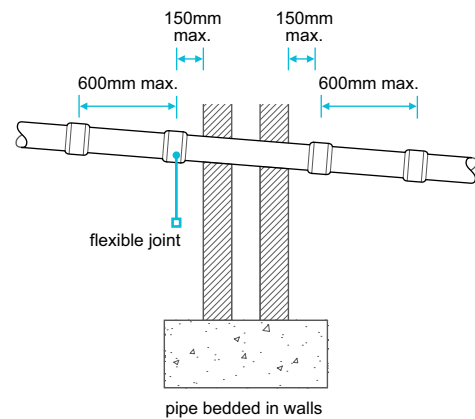
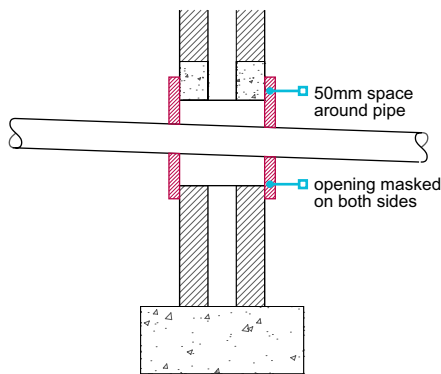
**Pipes passing through substructure walls**

Where drains pass through structural elements; allowance should be made to accommodate movement.

Pipes passing through substructure walls should accommodate movement by:

- a 50mm clearance all round
- a sleeve, with 50mm clearance all round and suitably sealed, or
- bedded pipes, connected on both sides of the wall with flexible joints located a maximum of 150mm from the face of the wall.

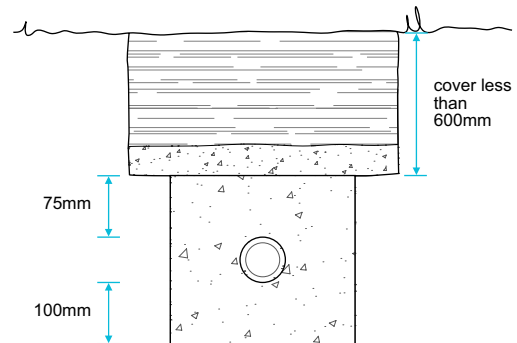
Flexible joints should be made in accordance with the pipe manufacturer's recommendations.



**Pipework under finishes**

Where drains pass under roads and drives, the final compaction should be sufficient to prevent later settlement.

<b>Rigid pipes less than 1.2m below road surface</b>	Should have: <ul style="list-style-type: none"> <li>■ where necessary, a minimum 100mm concrete encasement</li> <li>■ movement joints formed with compressible board at each socket or sleeve joint face</li> <li>■ flexible joints which remain flexible.</li> </ul>
<b>Flexible pipes less than 0.9m below road surface</b>	Should be protected by: <ul style="list-style-type: none"> <li>■ concrete bridging slabs, or</li> <li>■ surrounded with concrete reinforced as appropriate.</li> </ul>
<b>Garden areas</b>	Where flexible pipes are not under a road and have less than 600mm cover, where necessary they should have: <ul style="list-style-type: none"> <li>■ concrete paving slabs laid as bridging above the pipes, and</li> <li>■ a minimum 75mm of granular material between the top of the pipe and underside of the slabs.</li> </ul>

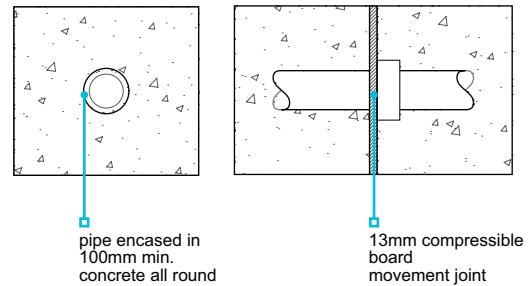




### Movement joints

Where rigid pipes are to be encased in concrete, movement joints should be:

- provided around the spigot next to the socket either at 5m maximum intervals or at each joint
- 13mm thick compressible board.



### Laying pipework <sup>5.3.15</sup>

**Pipework shall be laid to the designed lines and gradients. Issues to be taken into account include:**

- a) bedding
- b) sidefill and backfill.

### Bedding

Pipes should be firmly supported throughout their length and bedded as specified in the design to resist loads from overlying fill and traffic.

Where pipework is installed under a suspended floor and is supported on ground or fill where movement is likely to occur, additional provisions may be required. See Clause 5.3.8.

Bricks, blocks or other hard material should not be used as temporary supports to achieve the correct gradients, as they may create hard spots which can distort the completed pipe run.

Pipes should be either:

- bedded on granular material, minimum 100mm deep, or
- laid directly on the trench bottom, where the trench bottom can be accurately hand trimmed with a shovel but is not so soft that it puddles when walked on.

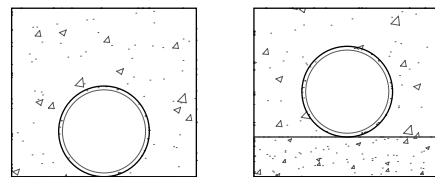
For 150mm diameter and 100mm diameter drains, a bed and surround pea gravel in accordance with Table 8 (to a thickness of 100mm all round the drain) will be acceptable for drains under gardens, paths and drives.

Proprietary systems should be assessed in accordance with Technical Requirement R3 and supported in accordance with the manufacturer's recommendations. Some proprietary systems permit a minimum of 50mm depth of bedding in certain circumstances.

Depressions should be formed where necessary in the trench bottom to accommodate pipe joints.

Pipe bedding, including the bedding material, should be in accordance with:

- BS EN 13242
- BS 5955
- BS EN 752.



Bedding material and specification should be in accordance with Table 8. Backfill and bedding that includes recycled or secondary materials should conform to the appropriate regulatory requirements for waste, as defined in the Waste Framework Directive 2008.

**Table 8:** Bedding size

Nominal pipe size	Bedding material complying with BS EN 13242
110mm flexible pipes 100mm rigid pipes	4/10mm pipe bedding gravel
160mm flexible pipes 150mm rigid pipes	2/14mm pipe bedding gravel

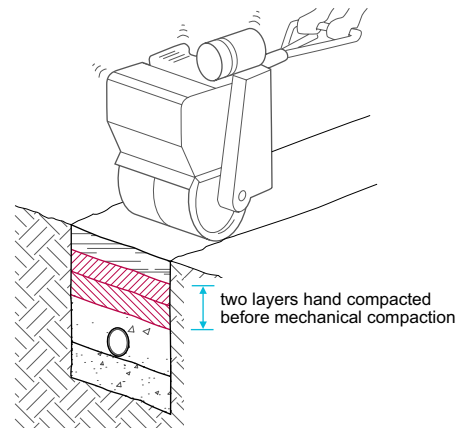
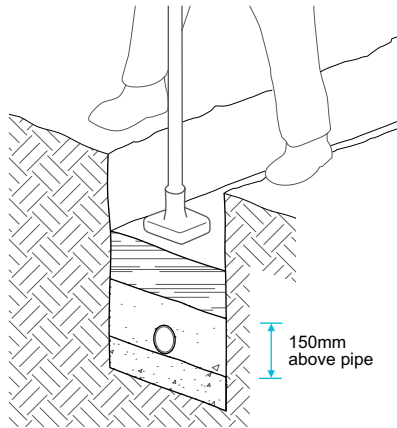
**Sidefill and backfill**

Sidefill and backfill should be placed as soon as the pipes have been bedded, jointed and inspected.

Sidefill should be either granular material or selected backfill material from the trench excavation, free from:

- stones larger than 40mm
- clay lumps larger than 100mm
- timber
- frozen material
- vegetable matter.

Backfill should be well compacted and placed in layers no deeper than 300mm. Mechanical compacting should only be used when compacted backfill is over 450mm above the crown of the pipe.

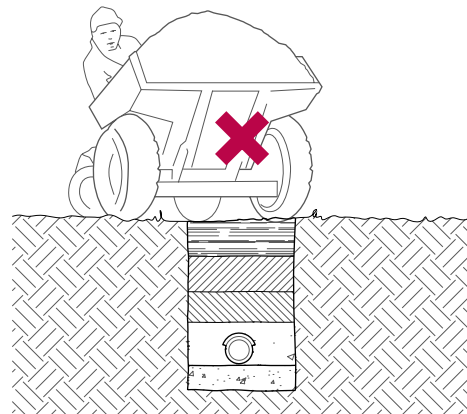


**Protection of work <sup>5.3.16</sup>**

**Drainage systems shall be suitably protected from damage by construction work.**

Damaged drainage will not be accepted, and it is recommended that:

- no heavy loading or underground work is permitted above, or near, unprotected drainage
- dumpers, trucks, fork lifts or other heavy vehicles are not driven along, or near, pipe runs.



**Testing <sup>5.3.17</sup>**

**All foul and surface water drainage systems shall be adequately watertight, and tested where appropriate.**

Inspection and testing should be arranged when required by:

- the local authority
- the sewerage undertaker
- NHBC.

Before backfilling, visual inspections are required and the builder is advised to test. When the home is handed over, the system must be in full working order and free from obstruction.

# Waterproofing of basements and other below ground structures

## CHAPTER 5.4

This chapter gives guidance on meeting the Technical Requirements for the waterproofing of basements and other structures below, or near to, ground level.

5.4.1	Compliance	02
5.4.2	Provision of information	02
5.4.3	Waterproofing	02
5.4.4	Ground conditions	03
5.4.5	Structural stability	04
5.4.6	Design considerations	04
5.4.7	Waterproofing systems	06
5.4.8	Handling, storage and protection	08



Raising Standards. Protecting Homeowners

### Introduction

This chapter includes guidance for walls, floors and foundations below, or near to, ground level that are intended to prevent the passage of water from the ground (including from sources such as run-off, burst pipes etc.) entering the building near to or below ground level.

Guidance for the following types of waterproofing systems is included in this chapter:

- Type A waterproofing barriers
- Type B structurally integral construction
- Type C drained cavity construction.

Constructions that are at risk of coming into contact with water and generally require waterproofing include:

- basements
- semi-basements
- below ground parking areas
- lift pits
- cellars
- storage or plant rooms
- service ducts, or similar, that are connected to the below ground structure
- stepped floor slabs where the retained ground is greater than 150mm.

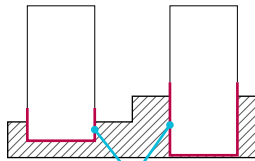
Types of construction that, depending on the findings of a risk assessment, may require waterproofing include:

- external walls where the lowest finished floor level is less than 150mm higher than the external ground level
- voids caused by split levels.

Typical examples of construction types:

- Waterproofing should be provided where due to the construction details and the ground conditions, there is a risk of contact with ground water (see Table 1)
- \_\_\_\_\_ Waterproofing is required

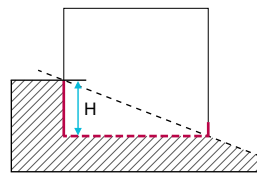
#### Basement



The external ground is raised above the internal floor for the perimeter of the building

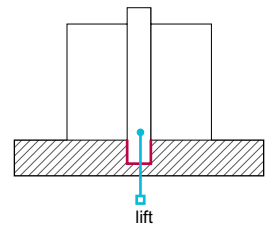
depth varies

#### Retained ground and semi-basement



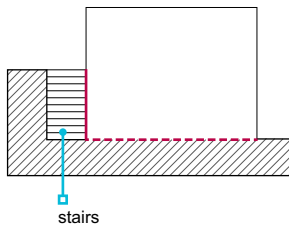
H = any point where the ground is above the finished floor level

#### Lift pit



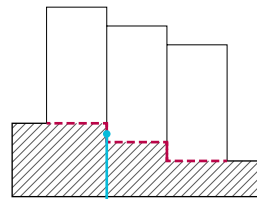
lift

#### Stairs adjacent to the structure



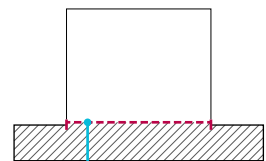
stairs

#### Stepped floor slabs where the retained ground is greater than 150mm



waterproofing required to walls where retained ground is greater than 150mm

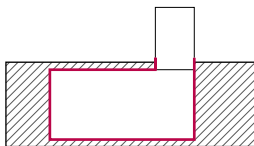
#### Raised external ground levels



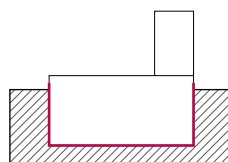
waterproofing required to walls and/or floors where there is a risk of contact with ground water

Also see Chapter 6.2 'External Timber Framed walls'.

#### Buried podium

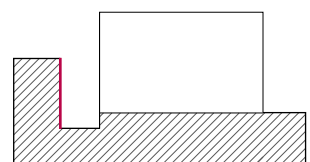


#### Raised podium

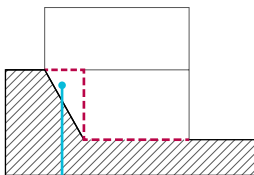


Also see Chapter 7.1 'Flat roof and balconies'.

#### Retaining walls forming lightwells



#### Split levels



structures adjacent to voids where water may accumulate

## Definitions for this chapter

For the purposes of this chapter the following definitions apply:

<b>Cavity drain membrane</b>	Semi-flexible sheet designed to form a cavity that intercepts water penetrating the structure and directs it to a suitable drainage point. See Type C drained cavity construction.
<b>Combined system</b>	For the purposes of this chapter, a combined system includes: <ul style="list-style-type: none"> <li>■ Type A and Type B</li> <li>■ Type A and Type C</li> <li>■ Type B and Type C.</li> </ul>
<b>Ground barrier</b>	A barrier used to resist the ingress of moisture and or ground gases into the building.
<b>Lowest finished floor level</b>	The top surface of the lowest finished floor, including lift pit floors, car park surfaces and other similar surfaces. Excluding coverings such as carpet and tiles.
<b>Type A waterproofing barrier</b>	A waterproofing barrier applied to the structural element being waterproofed, also known as tanking.
<b>Type A fully bonded barrier</b>	Type A barrier that forms part of a composite structural wall, including liquid applied and cementitious systems. Post-applied sheet membranes are not considered to be fully bonded barriers for the purposes of this chapter.
<b>Type A post applied membrane</b>	A sheet membrane applied to the completed structure typically with hot or cold adhesive
<b>Type B structurally integral construction</b>	The water-resistant properties of the retaining structure providing waterproofing to the building. This chapter provides specific guidance for the use of Type B concrete systems cast in- situ, with or without waterproofing admixtures. The principles are applicable to other Type B systems listed in BS 8102.
<b>Type C drained cavity construction</b>	Construction that incorporates a cavity, generally formed with a cavity drain membrane. Water is removed from the cavity via a managed drainage system.
<b>Waterproofing design specialist</b>	A suitably qualified person co-ordinating the team involved in the design of waterproofing to basements and other below ground structures.
<b>Waterproofing system</b>	A fully assessed and certified system of compatible materials and components used to provide waterproofing. These are normally considered to be Type A, B or C as defined above.
<b>Retained ground</b>	In this chapter retained ground levels are taken from the top of the retained ground to the lowest finished floor level.

### Compliance <sup>5.4.1</sup>

*Also see: Chapter 2.1, BS 8102 and 'Basements for dwellings; guidance document'*

**Basements and other below ground structures shall comply with the Technical Requirements.**

Waterproofing of basements and other below ground structures, including foundations, walls and floors that complies with the guidance in this chapter will generally be acceptable.

### Provision of information <sup>5.4.2</sup>

**Designs and specifications shall be produced in a clearly understandable format, include all relevant information and be distributed to all appropriate personnel.**

Design and specification information should be issued to site supervisors, relevant specialist subcontractors and/or suppliers and include the following information:

- A full set of current drawings.
- Details of joints, junctions and service penetrations.
- The manufacturer's information, including relevant parts of the system design manual.
- An installation method statement detailing the sequence of works.
- A ground condition report.
- Third-party certifications.
- Details of the waterproofing design specialist.

Design and specification information should be provided to NHBC at least eight weeks in advance of the works starting on site, in accordance with NHBC Rules.

### Waterproofing <sup>5.4.3</sup>

*Also see: BS 8102*

**The design of waterproofing systems shall be undertaken by a suitably qualified person and be appropriate for the specific performance required. Items to be taken into account include:**

- a) waterproofing design
- b) risk-based design

#### Waterproofing design

Waterproofing systems should be designed by a waterproofing design specialist. Designers who have successfully completed the Certified Surveyor in Structural Waterproofing (CSSW) qualification available from the Property Care Association (PCA) are generally

acceptable to NHBC. An alternative demonstration of competence may be acceptable, subject to successful review.

The waterproofing design specialist should be appointed in the early design stages to co-ordinate with other designers, including the engineer, and to ensure satisfactory integration of the waterproofing system.

### Risk-based design

Waterproofing should be appropriate to the risk, and generally assume exposure to a full height of water during the design life of the building.

Combined systems should be used where:

- a Grade 3 environment is needed, and
- the wall retains more than 600mm.

Alternatively, where the builder has demonstrated that the water table is permanently below the underside of the lowest floor slab, a Type B structurally integral concrete system is acceptable without further protection from a combined system.

The following Types of waterproofing are acceptable where a Grade 2 environment is needed and more than 600mm of ground is retained:

- Type A fully bonded barrier
- Type B
- Type C
- a combined system.

### Ground conditions <sup>5.4.4</sup>

*Also see: Chapter 4.1*

#### The waterproofing system shall take account of ground conditions.

The ground conditions should be fully considered by the engineer and waterproofing design specialist in the design of the waterproofing system.

NHBC may request investigation and a report of the ground conditions where the below ground waterproofed structure:

- retains more than 600mm of ground, measured from the top of the retained ground to the lowest finished floor level
- comprises more than 15% of the perimeter of an individual building (e.g. terraced homes, apartment blocks and detached garages), measured on plan.

The ground conditions report should take into account appropriate investigations, as described in Table 1.

**Table 1:** Investigation of ground conditions

Further investigation	Guidance and information
Desk study, including review of: <ul style="list-style-type: none"> <li>■ ground water and flooding issues</li> <li>■ flood potential of the site</li> <li>■ available ground water data</li> <li>■ SuDS impact assessment</li> <li>■ flood risk assessment</li> <li>■ topography of the site</li> <li>■ effects of adjacent surface finishes.</li> </ul>	<a href="http://www.environment-agency.gov.uk/homeandleisure/floods">www.environment-agency.gov.uk/homeandleisure/floods</a> <a href="http://www.bgs.ac.uk/research/groundwater/datainfo/levels/home.html">www.bgs.ac.uk/research/groundwater/datainfo/levels/home.html</a> <a href="http://www.metoffice.gov.uk/climate/uk/stationdata">www.metoffice.gov.uk/climate/uk/stationdata</a>
Contaminated or aggressive ground and/or ground water conditions.	Testing required where there is the potential for chemically aggressive ground and/or ground water.
Water level change, including potential for flash flooding and waterlogging.	Identifying likely fluctuations and short-term flooding events.
Impact assessment of ground water flow where the construction is likely to have a 'damming' effect.	Interpretative report by a qualified engineer, hydrologist or hydrogeologist to include: <ul style="list-style-type: none"> <li>■ assessment of the direction of ground water flow</li> <li>■ damming effects on the ground water regime</li> <li>■ damming effect of adjacent structures.</li> </ul>

Where it is necessary to establish the water table, a detailed hydrogeological assessment should be undertaken by a suitably qualified engineer, and include:

- long-term water level monitoring over at least one year to capture seasonal fluctuations
- short-term flooding events that typically occur during autumn and spring
- information based on a suitable number of boreholes monitored at a minimum of three-month intervals.

### Structural stability <sup>5.4.5</sup>

*Also see: Chapters 4.1, 4.2 and 5.1*

**Elements forming a waterproofing structure below ground including: foundations, walls and floors, shall adequately resist movement and be suitable for their intended purpose. Issues to be taken into account include:**

- |                      |                          |
|----------------------|--------------------------|
| a) site conditions   | d) movement              |
| b) structural design | e) design co-ordination. |
| c) durability        |                          |

#### Site conditions

Parts of the building constructed below ground level that form the structural elements of usable spaces should be designed by an engineer in accordance with Technical Requirement R5 where they are retaining more than 600mm. Issues that should be taken into account include:

- |                               |            |
|-------------------------------|------------|
| ■ characteristics of the site | ■ hazards. |
| ■ ground conditions           |            |

#### Structural design

The structure should be designed to take account of all imposed loads and actions, including:

- |  |  |
|--|--|
| ■ ground movement  | ■ buoyancy                                 |
| ■ lateral forces from ground water, retained ground and ground surcharge loads | ■ loading from other parts of the building |
|  | ■ temporary loading conditions.            |

#### Durability

The structure should be designed to be sufficiently durable against site hazards, including:

- |                |                                |
|----------------|--------------------------------|
| ■ chemicals    | ■ cyclical wet-dry conditions. |
| ■ frost action |                                |

#### Movement

Movement within the structure should be limited to the capacity of the waterproofing system's resistance to such movement, ensuring that the designed level of watertightness is achieved. Detailed guidance for the limitation of movement should be provided where appropriate.

Movement joints in below ground waterproofed structures should be avoided. Where it is necessary to provide movement joints, the design should ensure satisfactory in-service performance, including watertightness. Such joints should be accessible for maintenance, and not permanently concealed by other structural elements of the building.

#### Design co-ordination

Structural design should be co-ordinated with the design of the waterproofing.

### Design considerations <sup>5.4.6</sup>

*Also see: Chapter 5.3*

**The waterproofing of all elements, including walls, floors and foundations, forming below ground structures shall be suitable for intended use. Issues to be taken into account include:**

- |  |  |
|--|--|
| a) grade of waterproofing protection               | c) interface with the above ground structure   |
| b) waterproofing systems, materials and components | d) joints, abutments and service penetrations. |

#### Grade of waterproofing protection

Waterproofing systems should be designed to resist the passage of water and moisture to internal surfaces.

The waterproofing grade should be appropriate for the proposed use of the internal space and the equipment located within.

**Table 2:** Waterproofing grades

Grade	Description	Generally required for:
Grade 3	No water penetration acceptable and a dry environment provided where maintained by adequate ventilation.	Habitable accommodation.
Grade 2	No water penetration is acceptable although damp areas are tolerated.	Non-habitable areas, such as car parks, storage or plant rooms where the internal finishes are not readily damaged by moisture. (Some water ingress may occur where openings are provided in car parks, e.g. for ventilation. To minimise potential for standing water, refer to Chapter 9.1 'A consistent approach to finishes'. Car parks should be provided with drainage to a suitable outfall).
Grade 1	Some seepage and damp areas are tolerable, dependent on intended use.	Retaining walls typically used to form external lightwells. (Drainage may be required to deal with seepage).

Where there is doubt about potential use, minimum Grade 3 protection should be considered in the waterproofing design.

### Waterproofing systems, materials and components

Components forming the waterproofing system should be predefined and assessed to demonstrate suitable performance.

The assessment should specifically consider compatibility where materials and components are intended to be interchangeable between systems.

The design information and documentation should detail waterproofing systems, materials and components in accordance with the manufacturer's recommendations.

Proprietary waterproofing systems, materials and components should be assessed in accordance with Technical Requirement R3.

### Interface with the above ground structure

Waterproofing should extend at least 150mm above the external ground level and connect with the superstructure damp-proofing. This can generally be achieved by linking the below ground waterproofing system to a continuous cavity tray.

The connection between the below and above ground waterproofing should be bonded and formed with appropriate materials.

Where the waterproofing is linked to the above ground structure via a cavity tray, the materials should:

- compress to form a watertight seal
- be capable of taking the load.

Bitumen-based materials in accordance with BS 6398 or suitable materials assessed in accordance with Technical Requirement R3 should be used.

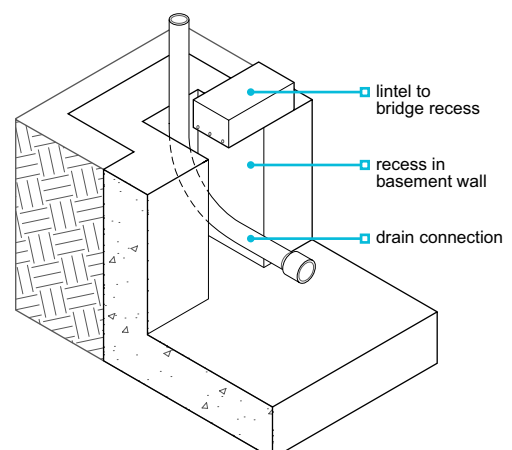
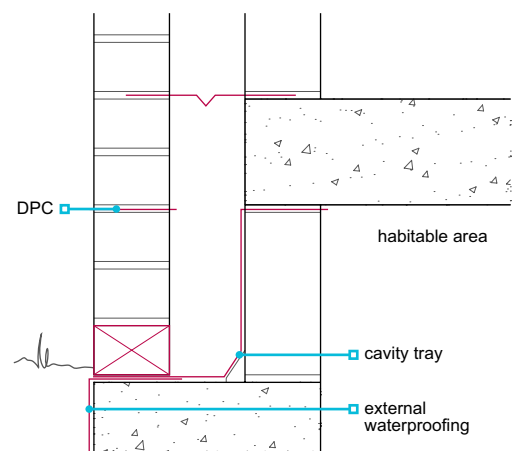
### Joints, abutments and service penetrations

The design of waterproofing systems should include the correct method and detailing to form joints, abutments and service penetrations, including those between:

- the waterproofing system and superstructure damp proofing
- horizontal and vertical waterproofing
- system components.

The manufacturer should confirm compatibility between different materials where they are used to form joints.

Details of how junctions and abutments are formed should be provided to site personnel. Proprietary components that are part of, or compatible with, the waterproofing system should be used for complex joints, abutments and service penetrations.





Penetrations through the waterproofing should be avoided where possible. Where penetrations cannot be avoided, the design should detail the method of waterproofing to ensure that it is watertight and durable.

Penetrations, including those for wall ties, services and drainage systems, should:

- be suitably separated to allow for proprietary seals to be correctly installed
- account for differential settlement and movement between the structure/finishes and services.

### Waterproofing systems <sup>5.4.7</sup>

*Also see: Chapters 3.1, 3.2, BS 8102 and 'Concrete basements. Guidance on the design and construction of in-situ concrete basement structures'*

**The waterproofing shall be suitable for intended use and installed in accordance with the design. Items to be taken into account include:**

- a) Type A waterproofing barriers
- b) Type B structure, integral
- c) Type C drained cavity
- d) ancillary components.

Appropriate sequencing of work will enable logical and timely construction of the waterproofing system and prevent unnecessary damage to completed elements of work. Installation should be undertaken in accordance with the design and the installation method statement detailing the sequence of works.

#### Type A waterproofing barrier

Type A systems generally accepted by NHBC when assessed in accordance with Technical Requirement R3 include:

- Post applied membrane (hot or cold adhesive)
- liquid-applied membranes
- geosynthetic (bentonite) clay liners
- mastic asphalt to BS 6925 or BS EN 12970
- cementitious systems
- pre-applied fully bonded systems
- proprietary systems or products assessed in accordance with Technical Requirement R3.

Plain polyethylene sheet should not be used as a waterproofing system.

Only fully bonded systems assessed in accordance with Technical Requirement R3 for the specific purpose should be used internally or in sandwich constructions.

Design at junctions and corners should account for proprietary components and be in accordance with the manufacturer's recommendations. Waterproofing barriers should return at corners to prevent water tracking behind.

The substrate to which the Type A system is to be applied should be clean, free from debris and prepared in accordance with the manufacturer's recommendations. Bonded sheet membranes should only be applied directly to masonry substrates that are smooth and have flush pointed joints.

Type A waterproofing should be installed in accordance with the manufacturer's instructions by operatives:

- who are suitably qualified or have been trained by the manufacturer or supplier, and
- who are fully aware of the design and the manufacturer's recommendations for installation.

Completed waterproofing should be protected by:

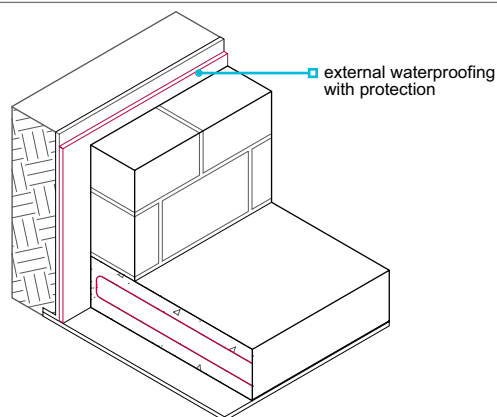
- protection board, or
- carefully placed backfill material.

The manufacturer's recommendations for climatic conditions at the time of installation should be followed.

#### Type B structure, integral construction, concrete and application

Structural design should be undertaken by an engineer in accordance with Technical Requirement R5. The design of in-situ Type B concrete systems should be in accordance with:

- BS EN 1992-1-1
- BS EN 1992-3
- Chapter 3.1 'Concrete and its reinforcement'.



Type B systems acceptable to NHBC include:

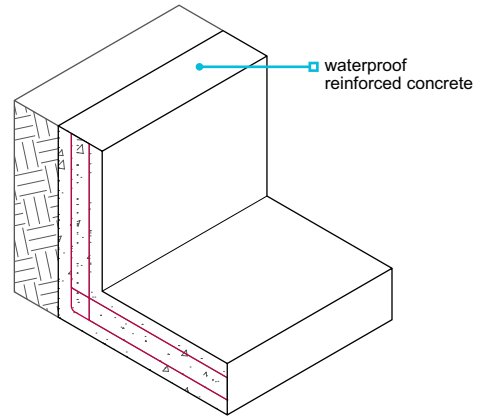
- in-situ concrete with or without admixtures and crack widths limited by design
- in-situ high-strength concrete with crack widths limited by design and post-construction crack injections
- precast concrete systems assessed in accordance with Technical Requirement R3.

Specialist advice should be sought where other Type B systems are specified. BS 8102 contains guidance for the use of Type B systems, including secant, contiguous and sheet piles.

Ready-mixed concrete should be of sufficient strength and durability, and from a supplier operating under a quality control system acceptable to NHBC such as:

- the Quality Scheme for Ready-Mixed Concrete (QSRMC), or
- the BSI Kitemark scheme.

Other suppliers may be accepted if they operate to a standard acceptable to NHBC.



The concrete mix should be agreed between the engineer and the waterproofing design specialist, and:

- achieve the necessary robustness, durability and waterproofing
- be suitable for the environmental exposure and ground conditions.

Type B waterproofing should be installed:

- by suitably qualified operatives who are fully aware of the requirements for placing concrete and reinforcement and for installing ancillary components used in Type B systems
- in accordance with the design.

The line, level and position of formwork and reinforcement should be checked prior to concrete placement to ensure that it is in accordance with the design.

Penetrations from tie bars etc. should be made good in accordance with the design.

Where joints are formed in concrete, surfaces should be clean and free of excessive laitance. Hydrophilic strips should be protected from water before the joint is formed.

Quality management systems and quality audits should be used to record and monitor the placement of concrete on site. Monitoring records should be supplied to NHBC as requested.

Design details for reinforced concrete structures should include:

- Concrete specification.
- The type of concrete.
- Concrete strength.
- Proportion of any admixture.
- Proposals for limiting crack widths.
- Consideration of temporary support to the formwork.
- Type and position of reinforcement.
- The method of making good holes in the concrete formed for shutter bolts and tie bars.
- Positioning of structural elements.
- Appropriate tolerances for the line and level of structural elements.

Joints between components, including day work joints, should be durable and made watertight with appropriate waterstops or hydrophilic strips. Kickers, generally cast as part of the slab, should be used to form the joint between floors and walls.

### Concrete with admixtures

Where the design of in-situ concrete waterproofing includes admixtures:

- the ratio of admixture to concrete specified in the design should take account of the recommendations of the admixture supplier
- the reinforcement should limit crack widths to 0.3mm for flexural cracks and 0.2mm for cracks that pass through the section
- suitable quality management systems and quality audits should be used to record and monitor the batching of admixture.

Admixtures should be:

- independently assessed, in accordance with Technical Requirement R3
- assessed according to the intended use
- used strictly in accordance with the manufacturer's recommendations.

### Concrete without admixtures

Where the design of in-situ concrete waterproofing does not include admixtures:

- high-strength concrete may be specified in order to achieve the necessary level of waterproofing, but post-construction crack injection may be required in order to deal with cracking induced by increased thermal and shrinkage strains
- the reinforcement should limit crack widths to 0.2mm for both flexural cracks and for cracks that pass through the section
- a minimum section thickness of 250mm should be used in the design.

### Type C drained cavity construction

Type C systems that include a cavity drain membrane which forms a waterproof barrier are acceptable to NHBC when assessed in accordance with Technical Requirement R3. Where a Type C system is formed using a drained masonry cavity wall, the guidance in BS 8102 should be considered.

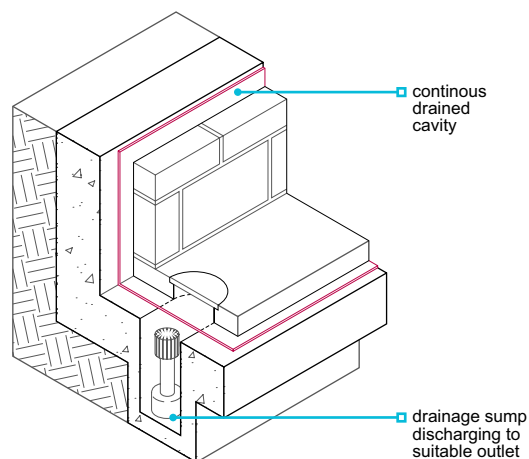
Type C systems should be designed to include a drainage system that adequately disposes of water to a suitable outlet, either by gravity or through a sump and pump. The drainage channel, sump and pump should include appropriately located access points for servicing and maintenance. To prevent backflow, the drainage system should be fitted with a one-way valve.

Type C waterproofing should be installed in accordance with the manufacturer's instructions by operatives:

- who are suitably qualified or have been trained by the manufacturer or supplier
- who are fully aware of the design and the manufacturer's recommendations for installation
- using the fixings recommended by the manufacturer.

Pump systems should operate automatically and include:

- a primary pump
- a secondary pump with battery or generator backup
- a suitable audio or visual alarm that indicates pump failure.



### Ancillary components

Ancillary components should be assessed as part of the waterproofing system. Alternatively, an assessment of compatibility and satisfactory performance should be provided for materials and products that are interchangeable between different systems.

Ancillary components include:

- preformed junctions and corners
- reinforcement
- waterstops
- hydrophilic strips.

## Handling, storage and protection <sup>5.4.8</sup>

**Waterproofing materials, products and systems shall be handled, stored and protected in a satisfactory manner to prevent damage, distortion, weathering or degradation. Issues to be taken into account include:**

- a) handling and storage
- b) protection from ongoing works.

### Handling and storage

Materials, products and systems should be transported, lifted, handled and stored in accordance with the manufacturer's recommendations.

### Protection from ongoing works

Design should consider the risk of damage caused by ongoing works. Details of suitable protection measures should be specified in the design and include:

- fixing of other components, such as skirtings, wall ties and wall linings
- protection of the waterproofing from backfilling.

Proprietary products and systems should be protected and tested before backfilling occurs.

# External masonry walls

## CHAPTER 6.1

This chapter gives guidance on meeting the Technical Requirements for external masonry walls.

6.1.1	Compliance	01
6.1.2	Provision of information	01
6.1.3	Structural design	01
6.1.4	Fire resistance	03
6.1.5	Acoustic resistance	03
6.1.6	Exposure	03
6.1.7	Thermal insulation	06
6.1.8	Concrete blocks	09
6.1.9	Bricks	09
6.1.10	Stone masonry	10
6.1.11	Construction of masonry walls	11
6.1.12	Lintels	14
6.1.13	Materials suitable for mortar	15
6.1.14	Mortar	15
6.1.15	Render	17
6.1.16	Cladding	17
6.1.17	DPCs and cavity trays	18
6.1.18	Wall ties	22
6.1.19	Handling materials	23
6.1.20	Cold weather working	23



Raising Standards. Protecting Homeowners

### Compliance <sup>6.1.1</sup>

Also see: Chapter 2.1

#### External walls shall comply with the Technical Requirements.

External masonry walls that comply with the guidance in this chapter will generally be acceptable.

### Provision of information <sup>6.1.2</sup>

#### Designs and specifications shall be produced in a clearly understandable format, include all relevant information and be distributed to the appropriate personnel.

Designs and specifications should be issued to site supervisors, relevant specialist subcontractors and suppliers, and include the following information:

- Construction materials.
- Wall layout with all dimensions shown.
- Position and size of openings.
- Wall layouts and elevations with dimensions shown.
- Coursing of bricks and blocks in relation to storey heights and opening positions.
- All junctions, indicating position of DPCs and cavity trays (isometric sketches are recommended for complicated junctions).
- Position and type of lintels.
- Position of restraint straps.
- Cavity closers.
- Reveals.
- How support is given to other elements, e.g. padstones and wall plates.
- Movement joints.
- Acceptable methods of pointing or mortar joint finish.
- Type of insulant to be used.
- Type, spacing and location of wall ties.

Where proprietary products are to be used, manufacturers generally have specific requirements for fixing and/or assembly. This information should also be made available for reference on site so that work can be carried out satisfactorily in accordance with the design and specification.

### Structural design <sup>6.1.3</sup>

#### External masonry shall be designed to support and transfer loads to foundations safely and without undue movement. Issues to be taken into account include:

- a) compliance with relevant standards
- b) lateral restraint
- c) point loads
- d) bonding
- e) movement joints.

#### Compliance with relevant standards

Design of masonry walls should comply with relevant standards:

Structural design	BS EN 1996-1-1 'Eurocode 6. Design of masonry structures. General rules for reinforced and unreinforced masonry structures'.
Intermediate floors, roofs and roofs designed to provide lateral restraint to external walls	BS 8103 'Structural design of low-rise buildings'.
Ancillary components	BS EN 845-1 'Specification for ancillary components for masonry'.
Walls of homes, or buildings containing homes, over three storeys high	Designed by an engineer in accordance with Technical Requirement R5.

#### Lateral restraint

##### Lateral restraint provided by concrete floors:

Concrete floors, with a minimum bearing of 90mm onto the wall, can provide adequate restraint. Concrete floors running parallel to, and not built into, walls require restraint straps to provide restraint to the wall.

##### Lateral restraint provided by timber floors:

Timber joisted floors can provide adequate restraint when joists are carried by ordinary hangers to BS EN 845, and connected to the wall with restraint straps. In buildings up to two storeys, timber joisted floors can provide adequate restraint without strapping when:

- the minimum bearing onto masonry is 90mm (or 75mm onto a timber wall plate), or
- joists are carried by BS EN 845-1 restraint-type hangers with performance equivalent to a restraint strap spaced at a maximum of 2m centres.

#### Point loads

Where padstones and spreaders are required, they should be located beneath areas of concentrated loads.

### Bonding

Where partition walls abut an external wall constructed of similar materials, fully bonded or tied joints are acceptable. To reduce the risk of cracking, a tied joint is preferable where:

- materials have dissimilar shrinkage or expansion characteristics, e.g. dense concrete and aerated concrete
- there is a connection between a load-bearing wall on foundations and a non load-bearing wall supported on a ground-bearing slab.

Tied joints should be formed using expanded metal, wire wall ties or a proprietary equivalent, spaced at maximum 300mm intervals.

### Movement joints

Movement joints should be included in long lengths of walling to reduce unsightly cracking, and detailed so that stability is maintained. Where possible, joints should be hidden in corners, or behind rainwater pipes, and:

- run the full height of the superstructure masonry wall
- continue from those provided in the substructure to the superstructure (movement joints may be needed in the superstructure and not in the substructure, providing suitable allowance is made for relative movement).

Vertical movement joints should be provided in the outer leaf, in accordance with Table 1.

**Table 1:** Suitable dimensions for movement joints

Material	Joint width (mm)	Normal spacing (m)
Clay brick	16	12 (15 maximum)
Calcium silicate brick	10	7.5 – 9
Lightweight concrete block and brick (autoclaved or using lightweight aggregates) <sup>(2)</sup>	10	6
Dense concrete block and brick (using dense aggregate) <sup>(2)</sup>	10	7.5 – 9
Any masonry in a parapet wall	10	Half the above spacings and 1.5 from corners (double frequency)

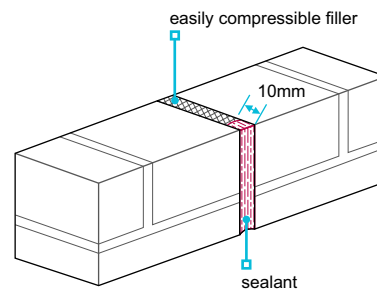
**Notes**

- 1 Manufacturer's guidance for the provision of movement joints and bed joint reinforcement should be considered.
- 2 Lightweight concrete masonry units are generally made of aggregates that have a gross density not exceeding 1,500 kg/m<sup>3</sup>. Dense concrete masonry units are generally made of aggregate that have a gross density exceeding 1,500 kg/m<sup>3</sup>.

The spacing of the first movement joint from a return should not be more than half of the dimension in Table 1.

Movement joints are not generally necessary in the inner leaf of cavity walls, but consideration should be given to providing:

- movement joints in rooms with straight unbroken lengths of wall over 6m
- bed joint reinforcement as an alternative to movement joints in areas of risk, e.g. under window openings.



Wall ties should be provided on either side of movement joints, in accordance with Clause 6.1.18.

Where masonry walls form panels in a framed structure, movement joints should be provided in accordance with BS EN 1996-2.

Movement joints should be formed using the correct materials, and account taken of:

- joint width and depth
- anticipated movement and capability of the material
- surface preparation and backing materials
- likely design life of the joint.

Clay bricks expand and require movement joints formed from easily compressible materials, such as:

- flexible cellular polyethylene
- cellular polyurethane
- foam rubber.

The following materials are acceptable for use in contraction joints in concrete brickwork:

- Hemp.
- Fibreboard.
- Cork.

Where movement joints are provided to control shrinkage in concrete blockwork, they may be made as simple vertical joints filled with mortar, and sealed.

Sealant should be a minimum of 10mm deep to ensure a good bond. Where the joint is in a freestanding wall, the filler will require sealant at:

- both exposed edges
- the top, where the joint is carried through any coping.

### Fire resistance <sup>6.1.4</sup>

**External cavity walls shall adequately resist the passage of fire.**

Cavities should be closed with cavity closers, in accordance with Building Regulations.

### Acoustic resistance <sup>6.1.5</sup>

**External walls adjacent to separating walls shall be designed to resist flanking sound transmission.**

Acceptable levels of sound reduction between homes may be achieved by:

- the inner leaf of an external cavity wall having sufficient density
- allowing appropriate spacing between the openings in external walls.
- sealing air paths

The density of external walls and the position of openings adjacent to separating walls should be in accordance with Building Regulations and, where relevant, an assessment which complies with Technical Requirement R3.

### Exposure <sup>6.1.6</sup>

*Also see: Chapter 6.7*

**External walls shall be suitable for their exposure and resist the passage of moisture to the inside of the home. Issues to be taken into account include:**

- a) durability
- b) rain penetration
- c) frost attack.

### Durability

Masonry can become saturated, and may remain so for long periods. Therefore, precautions should be taken to resist frost damage and sulfate attack affecting:

- parapet walls and copings
- masonry below the DPC at ground level
- sills and projections
- freestanding walls.

Bricks and mortar should comply with BS EN 1996-1-1 and the manufacturer's recommendations. In addition, the following mortar mixes can be used with ordinary Portland cement or sulfate-resisting cement:

- Air-entrained 1:1:5½ cement:lime:sand.
- Air-entrained 1:½:4½ cement:lime:sand.

Sulfate-resisting cement should be used where S1 clay bricks are used in the following situations:

- Below the DPC where there are sulfates present in the ground.
- Parapets.
- Freestanding walls.
- Retaining walls.
- Rendered walls.
- Areas of severe, or very severe, exposure to driving rain.

Reclaimed bricks should only be used where in accordance with Technical Requirement R3.

### Rain penetration

In prolonged periods of driving rain, water will penetrate the outer leaf of a masonry wall. The following should be taken into account:

- Site-specific exposure to wind-driven rain.
- Design detailing for the local exposure, and the likely quality of workmanship on site.
- Suitability of the wall construction and insulation method.

Exposed parts of the building should be given particular attention when selecting a suitable construction method, as this may affect the choice for the whole building.

Complete resistance can only be achieved with an impervious cladding. However, the following approaches can reduce the risk of rain penetration:

- Providing cladding to the wall.
- Increasing the clear cavity width (minimum 50mm) or the width of full-fill cavity insulation (increasing the cavity width for full-fill cavity insulation greatly reduces the risk of rain passing through the cavity).
- Rendering the wall and specifying crack-resistant backing material.

- Designing protective features to keep the wall dry, e.g. projecting sills and deep overhanging eaves and verges.
- Ensuring mortar joints are fully filled. Where full cavity insulation is proposed, recessed joints should not be used.
- Following the recommendations of any assessment of the insulation and the manufacturer's recommendations.
- Ensuring that cavities are not bridged.

Cavities should be continuous around enclosed porches and habitable areas.

Insulation should be in accordance with Clause 6.1.7 and Table 2. In Scotland, the cavity should not contain full-fill insulation. In Northern Ireland and the Isle of Man, it is not permissible to fill cavities with pumped thermal insulants at the time of construction.

In Scotland, Northern Ireland, the Isle of Man and in other places where the exposure to driving rain is very severe, masonry should form a rebate at the reveals of openings to avoid a straight through joint where the frame abuts the masonry, or a proprietary cavity closer assessed in accordance with Technical Requirement R3 should be used.

Sills, copings and similar features should be weathered and throated unless adequate alternative provision is made to protect the brickwork from saturation, frost damage and staining.

Variations to the exposure shown on the map can only be made by site-specific calculations using BS 8104 'Code of practice for assessing exposure of walls to wind-driven rain'.

Adapted from BRE report 'Thermal Insulation: avoiding risks'.

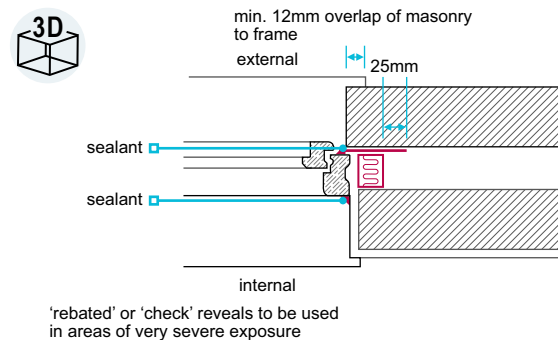
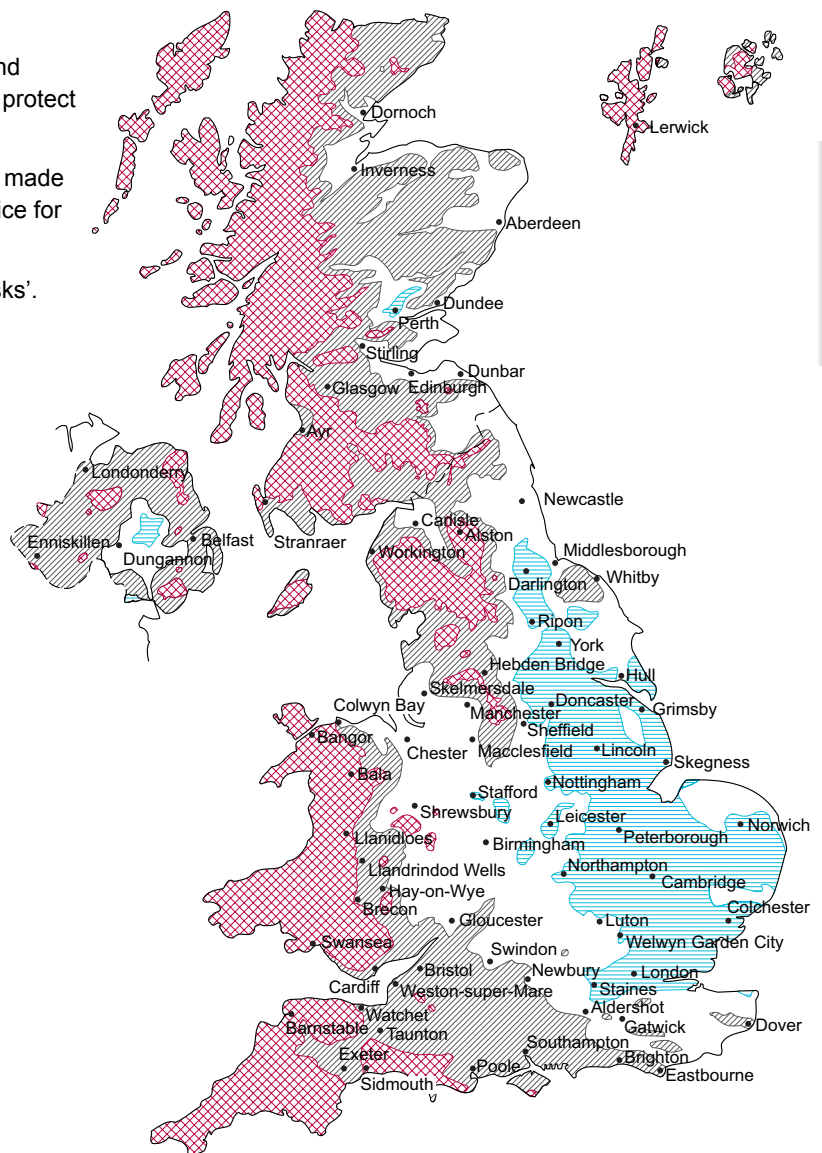


Figure 1: Exposure zones

Exposure zones	Exposure to wind-driven rain (litres/m <sup>2</sup> per spell)
	Very severe 100 or more
	Severe 56.5 to less than 100
	Moderate 33 to less than 56.5
	Sheltered Less than 33





### Frost attack

Common factors which increase the level of frost attack include:

- degree of exposure (incidence of frost)
- saturation of the masonry
- frost resistance of the masonry

Good brickwork detailing can limit persistent wetting and reduce the risk of frost attack, for example:

- Paths should drain away from walls to avoid saturating bricks near the ground.
- Sills, copings and similar features should have a weathered upper surface.

Copings should have:

- a generous overhang
- throatings a minimum of 40mm clear of the wall

The following should be taken into account:

- Bricks that are not frost-resistant (F0,S2 or F0,S1 to BS EN 771) may not be acceptable for use externally, unless completely protected by a cladding which can adequately resist the passage of water.
- Where there is a risk that brickwork may be persistently wet, bricks should be specified that are low in soluble salts. Where clay, F2,S2 or F1,S2 to BS EN 771 should be used.
- Only clay bricks designated L by BS EN 771 have a low limit on their soluble salt content. In persistently wet conditions, clay bricks of S1 designation may advance sulfate attack on the mortar.
- Painted or decorated finishes can trap moisture in external brickwork and increase the risk of frost damage, sulfate attack or other detrimental effects. They should not be applied to S1 designation bricks without written agreement from the brick manufacturer.

In Scotland, all clay bricks used as facings should be frost-resistant, F2,S2 or F2,S1 to BS EN 771.

This applies particularly to bricks such as fletton facings which are moderately freeze-/thaw-resistant (F1,S2 or F1,S1). In addition, manufacturer's recommendations on suitability should be followed, including the choice and use of mortar and the type of pointing.

#### Severe exposure to frost attack

The shaded areas on the map opposite have a frost over 60 days in a year, annual rainfall over 1m and are 90m above sea level. They are therefore considered to be at severe exposure to frost.

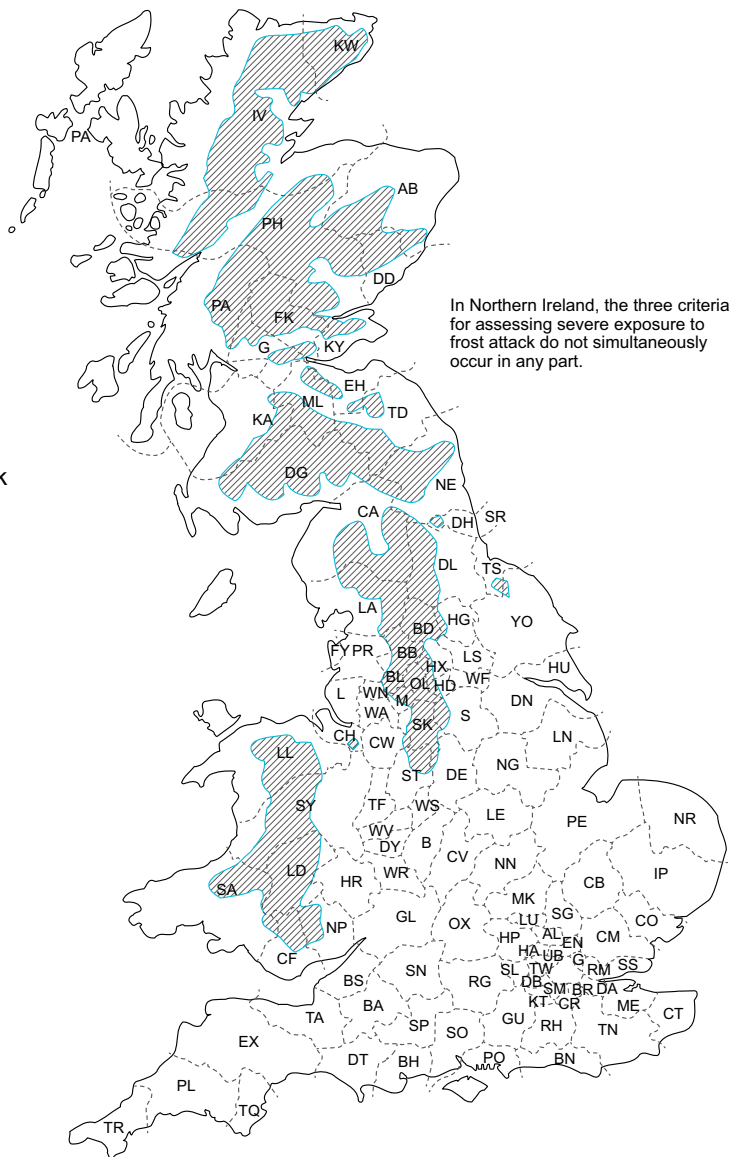
In areas of severe exposure to frost, the following types of brick are acceptable:

- Clay facing bricks which are frost-resistant F2,S2 or F2,S1 to BS EN 771.
- Clay bricks which are classified in the manufacturer's published recommendations as satisfactory for the exposure.
- Calcium silicate bricks of at least compressive strength Class 30 and declared as freeze/thaw resistant to BS EN 771.

- localised protection of the masonry by roof overhangs, trees and other buildings.

- A coping or capping should be provided for all parapet walls, chimneys and freestanding walls unless clay bricks of F2,S1 or F2,S2 classification to BS EN 771 are used.

- a continuous supported DPC which projects beyond the line of the wall.



- Concrete bricks with a minimum strength of 20N/mm<sup>2</sup>
- Concrete blocks with a minimum density of 1,500kg/m<sup>3</sup> or more than 7.3N/mm<sup>2</sup> strength classification.
- Most types of aerated concrete blocks with render.



Where cavity insulation is used:

- mortar joints, including perpend, should be solidly filled with mortar
- mortar droppings should be removed from wall ties and the edges of insulation materials
- excess mortar should be struck smooth from the inside of the outer leaf.

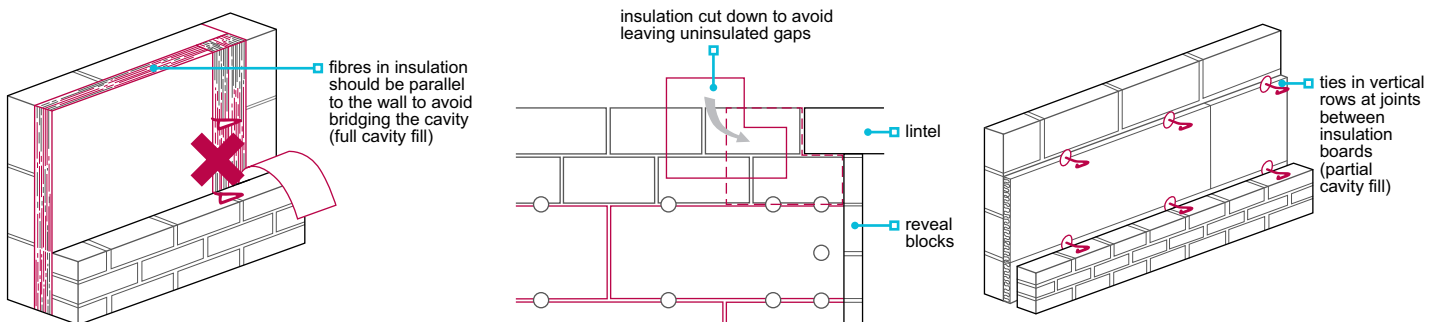
The first row of insulation boards or batts should be supported on wall ties:

- with a minimum of two ties to each board or batt
- which coincide with horizontal joints in the insulation.

Where wall ties need to be closely spaced, e.g. at reveals, it is acceptable to make a neat cut in the insulation to accept the extra ties.

Insulation boards for partial fill should:

- be stored flat without bearers, otherwise they may distort, making them difficult to fix against the wall
- be rejected where warped.



All retro-fill insulation materials, including UF foam, blown mineral fibre and expanded polystyrene beads should be:

- installed by a member of a surveillance scheme acceptable to NHBC
- installed by operatives trained by the assessment holder, and approved by the assessment holder and the assessing organisation.

### Insulation materials

Insulation should be:

- UF foam to BS 5617 and installed in accordance with BS 5618, or
- assessed in accordance with Technical Requirement R3.

### Construction type

The following are recommendations and guidance according to construction type:

#### Partial cavity insulation

Where partial cavity insulation is installed:

- it should only be fixed against the cavity face of the inner leaf
- a 50mm clear cavity between the partial cavity insulation and the outer leaf should be maintained
- wall ties long enough to allow a 50mm embedment in each masonry leaf should be used.

In areas of very severe exposure in England and Wales, a residual cavity of 75mm is required where the outer leaf is fairfaced masonry.

#### Full cavity insulation

Where the cavity is to be fully filled with insulation:

- the type of insulation, its thickness and the wall construction should be suitable for the exposure of the home. (see Table 2)
- render on an external leaf of clay bricks (F2,S1 or F1,S1 designation bricks to BS EN 771) is not permitted In areas of severe or very severe exposure to wind-driven rain
- mortar joints should not be recessed
- painted finishes on bricks or render are not acceptable where they are likely to cause damage (including frost damage or sulfate attack).

**Table 2:** Suitable wall constructions for use with full-fill cavity insulation

Exposure category	Suitable wall construction	Minimum insulation thickness (mm)		
		Built-in insulation	Retro-fill (other than UF foam)	UF foam
Very severe	Any wall with impervious cladding	50	50	50
	Fairfaced masonry with impervious cladding to all walls above ground storey	100	100	N/A
	Any wall fully rendered <sup>(2)</sup>	75	75	N/A
	Fairfaced masonry <sup>(1)</sup>	N/A	N/A	N/A
Severe	Any wall with impervious cladding or render <sup>(2)</sup>	50	50	50
	Fairfaced masonry with impervious cladding or render <sup>(2)</sup> to all walls above ground storey	50	75	50
	Fairfaced masonry	75	75	N/A
Moderate	Any wall with impervious cladding or render	50	50	50
	Fairfaced masonry with impervious cladding or render to all walls above ground storey	50	50	50
	Fairfaced masonry	50	75	75
Sheltered	Any wall with impervious cladding or render	50	50	50
	Fairfaced masonry with impervious cladding or render to all walls above ground storey	50	50	50
	Fairfaced masonry	50	50	50

**Notes**

- 1 In very severe exposure locations, fairfaced masonry with full cavity insulation is not permitted.
- 2 Render on an external leaf of clay bricks (F2,S1 or F1,S1 designation bricks to BS EN 771) in severe or very severe exposures is not permitted where the cavity is to be fully filled with insulation.
- 3 This table covers walls where the external leaf does not exceed 12m in height.
- 4 The exposure category of the home is determined by its location on the map showing categories of exposure to wind-driven rain.
- 5 Fairfaced masonry includes clay, calcium silicate and concrete bricks and blocks and dressed natural stone laid in an appropriate mortar preferably with struck, weathered or bucket handle joints. Cavity walls of random rubble or random natural stone should not be fully filled.
- 6 Recessed mortar joints should not be used.
- 7 In Scotland, it is not permissible to fill the full width of the cavity with any thermal insulation at the time of construction.
- 8 In Northern Ireland and the Isle of Man, it is not permissible to fill the cavity with pumped thermal insulants (for example, UF foam) at the time of construction.

The thickness of materials should be as required in the design, and in accordance with Building Regulations.

Guidance for retro-filling cavities:

<b>Northern Ireland and the Isle of Man</b>	Not permitted to fill cavities with pumped thermal insulants at the time of construction.
<b>Scotland</b>	Not permitted to fill the cavity fully with any thermal insulants at the time of construction.
<b>England and Wales</b>	In accordance with the guidance in this chapter.

**Inner leaf of insulated blockwork**

Types of blockwork include:

- lightweight aerated concrete
- lightweight aggregate blocks
- voided blocks with insulation infill
- blocks faced with insulation material.

For insulated blockwork:

- manufacturers' recommendations should be followed
- a clear 50mm wide cavity should be maintained
- blocks should be capable of supporting concentrated loads
- the correct type of joist hanger for the type and size of both the block and joist should be used
- long unbroken lengths of blockwork should be avoided
- precautions should be taken to reduce risk of shrinkage cracking
- restrictions on chasing for services when using voided blocks should be noted.

**Insulated dry linings**

Where an insulated dry lining contains a combustible insulant, to prevent early collapse of the lining in a fire, the plasterboard should be:

- a minimum of 12.5mm thick
- mechanically fixed to the masonry inner leaf.

**Dual insulation**

Where partial cavity insulation is used in addition to an insulated block inner leaf, the composite construction should be assessed in accordance with Technical Requirement R3.

### Concrete blocks <sup>6.1.8</sup>

**Concrete blocks shall be capable of supporting intended loads, have appropriate thermal resistance and be resistant to the adverse effects of climate. Issues to be taken into account include:**

- a) intended loads
- b) freeze/thaw and sulfate attack
- c) thermal resistance.

#### Intended loads

Blocks should:

- comply with BS EN 771 and be used in accordance with BS EN 1996-2
- not be used where they do not support the required load-bearing capacity of the wall
- be used in accordance with the manufacturer's recommendations.

The maximum load-bearing capacity of the wall should not exceed the manufacturer's recommendations. Other factors may dictate the strength of blocks required in certain circumstances, e.g. sulfate resistance may require blocks of greater strength.

For one and two storey homes, blocks with a minimum compressive strength of 2.9N/mm<sup>2</sup> should be adequate.

For three storey homes or those with storey heights over 2.7m, 7.3N/mm<sup>2</sup> blocks are required for certain parts of the structure, unless structural design shows that strengths lower than 7.3N/mm<sup>2</sup> are adequate.

#### Freeze/thaw and sulfate attack

Concrete blocks used in the outer leaf without protective cladding or render should:

- have a compressive strength exceeding 7.3N/mm<sup>2</sup>
- have a density exceeding 1,500kg/m<sup>3</sup>
- be made with dense aggregate to BS EN 12620, or
- be lightweight aerated concrete blocks having had their suitability confirmed by the manufacturer.

Where there are sulfates in the ground, concrete blocks should not be used below the DPC unless suitability is confirmed by the block manufacturer. Where this is permissible, the mortar should be sulfate-resisting with a mix suitable for the level of sulfates in the ground.

#### Thermal resistance

Concrete blocks may have been specified according to thermal performance and strength. Alternative concrete blocks should not be used without the designer's acceptance.

### Bricks <sup>6.1.9</sup>

**Bricks shall be capable of supporting intended loads and have appropriate resistance to the adverse effects of freeze/thaw and sulfate attack.**

The design strength of bricks should comply with:

- BS EN 1996-1
- the design.

**Table 3:** Classification of clay bricks according to their freeze/thaw resistance and active soluble salt content in accordance with BS EN 771-1

Durability	Freeze/thaw resistance	Active soluble salt content
F2,S2	Freeze-/thaw-resistant (F2), durable in all building situations	(S2) low
F2,S1	Freeze-/thaw-resistant (F2), durable in all building situations	(S1) normal
F1,S2	Moderately freeze-/thaw-resistant (F1), durable except when saturated and subject to repeated freezing and thawing	(S2) low
F1,S1	Moderately freeze-/thaw-resistant (F1), durable except when saturated and subject to repeated freezing and thawing	(S1) normal
F0,S2	Not freeze-/thaw-resistant (F0), liable to be damaged by freezing and thawing	(S2) low
F0,S1	Not freeze-/thaw-resistant (F0), liable to be damaged by freezing and thawing	(S1) normal

Calcium silicate and concrete bricks contain no significant active soluble salts. Information on their durability is given in this chapter.

**Clay bricks**

Bricks that are freeze-/thaw-resistant (F2,S2 or F2,S1 to BS EN 771) should be used where there is a high risk of prolonged wetting and freezing including:

- external facing work in Scotland
- areas of the country subject to exceptionally severe freeze/thaw exposure. See Clause 6.1.6.
- exposed parts, including copings, sills, parapets and chimneys which have no overhang to provide protection.

In areas of severe freeze/thaw exposure outside Scotland, bricks that are moderately freeze-/thaw-resistant (F1,S1 or F1,S2 to BS EN 771) may be used for general wall areas, provided they are classified in the manufacturer's published recommendations as satisfactory for the exposure.

Bricks that are not freeze-/thaw-resistant (F0,S2 or F0,S1 to BS EN 771) are not acceptable for use externally, unless completely protected by a cladding which can satisfactorily resist the passage of water.

Where brickwork may become saturated, moderately freeze-/thaw-resistant bricks (F1,S1 or F1,S2 to BS EN 771) are not appropriate where there is a risk of vulnerability to frost. In saturated conditions, sulfate-resisting cement mortar is required for S1 designation bricks.

For one and two storey homes, clay bricks to BS EN 771, with a minimum compressive strength of 9N/mm<sup>2</sup> should be adequate.

For three storey homes; clay bricks to BS EN 771 with a minimum compressive strength of 13N/mm<sup>2</sup> are acceptable.

**Concrete bricks**

Concrete bricks have a direct relationship between strength and durability, including freeze/thaw resistance. Most concrete bricks have a strength of 20N/mm<sup>2</sup> and are durable in most situations. For copings and sills, bricks with a compressive strength of 36N/mm<sup>2</sup> should be used.

**Calcium silicate bricks**

Calcium silicate bricks do not contain significant amounts of soluble sulfates and may be suitable where sulfate-bearing soil and ground water conditions exist. Where calcium silicate bricks are used, it should be in accordance with the manufacturer's recommendations.

Bricks of compressive strength Class 20 (BS EN 771-2) are suitable for most applications.

Bricks of strength Class 30 and declared as freeze-/thaw-resistant to BS EN 771-2 are recommended in the following areas:

- severe freeze/thaw exposure
- where bricks may be persistently wet, e.g. parapets, chimneys, sills and below the DPC.

**Reclaimed bricks**

Reclaimed bricks:

- should be used in accordance with Technical Requirement R3
- may be unsuitable for external work because of a high salt content or a lack of freeze/thaw resistance
- should be considered as F1,S1 or F1,S2 to BS EN 771 and used accordingly
- which have previously been used internally or which were fully protected may be unsuitable in external situations.
- may require independent certification of suitability

It is advisable to know where reclaimed bricks came from, and if they were used internally or externally.

**Special shaped bricks**

Special shaped bricks should conform to BS 4729.

**Stone masonry <sup>6.1.10</sup>**

**Stone masonry shall be constructed to an acceptable standard, including the performance standards for brick and block where applicable. Walls shall be capable of supporting the intended loads and have appropriate resistance to the adverse effects of freeze/thaw.**

Stone masonry should comply with the following:

<b>Stone for masonry</b>	BS EN 771-6 'Specification for masonry units. Natural stone masonry units'
<b>Cast stone masonry units</b>	BS EN 771-5 'Specification for masonry units. Manufactured stone masonry units' or BS 1217 'Cast stone. Specification'
<b>Stone masonry, natural or cast</b>	BS EN 1996 'Design of masonry structures'

Stone masonry will be acceptable where it:

- provides an adequate weather-resisting structure in conjunction with any brick or block backing, and/or vertical DPMs
- complies with the guidance in this chapter for brickwork/blockwork
- follows good local recognised practice to provide a high standard.

### Construction of masonry walls <sup>6.1.11</sup>

Also see: Chapter 7.1, 9.1 and PD 6697:2010

**Construction shall ensure a satisfactory standard of brickwork and blockwork. Issues to be taken into account include:**

- a) finished appearance
- b) bonding
- c) construction
- d) openings
- e) corbelling
- f) chasing for services
- g) protection of ancillary components.

#### Finished appearance

The appearance of a masonry wall depends upon the:

- materials used
- setting out
- workmanship.

When setting out masonry, avoid:

- cutting bricks or blocks, except when it is essential
- irregular or broken bonds, particularly at openings.

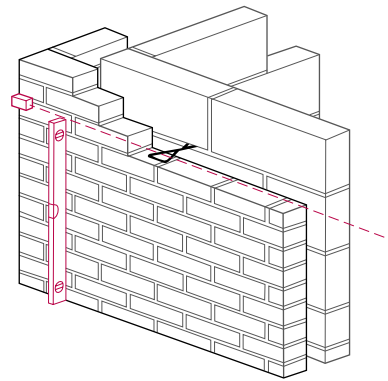
All work should be reasonably level and true, and:

- the bond detailed in the design used
- perpendicular joints kept in line and plumb
- courses kept level by using lines and spirit levels.

To keep courses to the correct height, use a gauge rod marked with the height of windows, doors and floors.

Where a number of openings of similar width are being formed, use a rod cut to the required size to check the width of openings as the work rises.

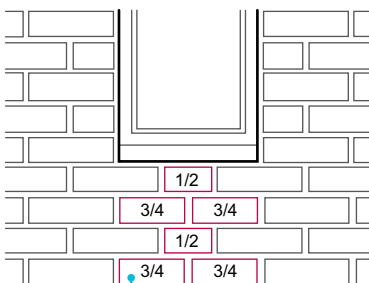
Brickwork and blockwork should not be subjected to vibration until the mortar has set.



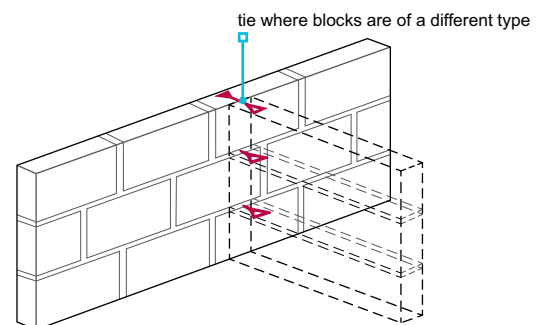
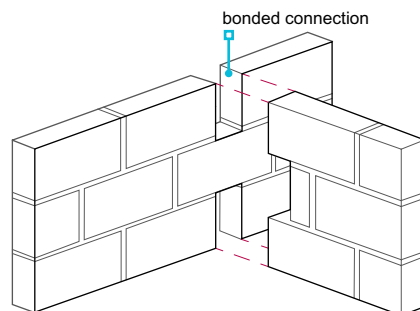
#### Bonding

A regular bonding pattern should be maintained. External walls should be bonded to partitions and party walls as required by the design. Either:

- tooth every alternate course, or
- tie with wall ties, expanded metal or equivalent at maximum 300mm vertical centres.



brick bond set out at the base of the wall to ensure that cut bricks occur below openings



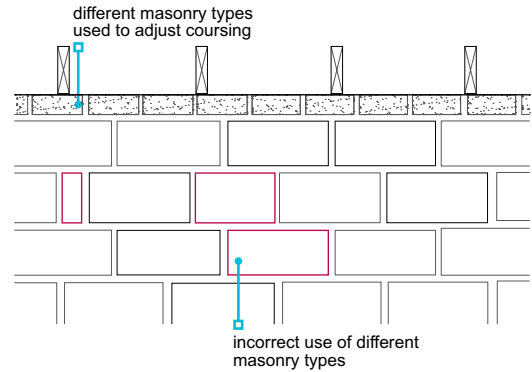
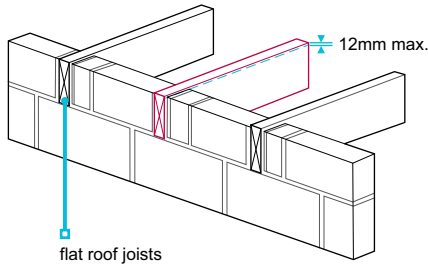
Where joist hangers are not used, joist filling should be brickwork or blockwork and without excessive mortar joints.

Joist filling should be:

- 12mm below the top of flat roof joists to allow for timber shrinkage, and
- checked to ensure the cold roof ventilation is not blocked.

Clay bricks and concrete blocks should not be mixed. Where a different size of masonry unit is needed to ensure correct coursing, small units of the same material should be used to reduce cracking and problems due to different thermal insulation properties.

Where the inner leaf of a cavity wall is being used for thermal insulation, and where a different size of masonry unit is used to ensure correct coursing, the unit should have similar thermal insulation properties to the masonry used for the rest of the wall.

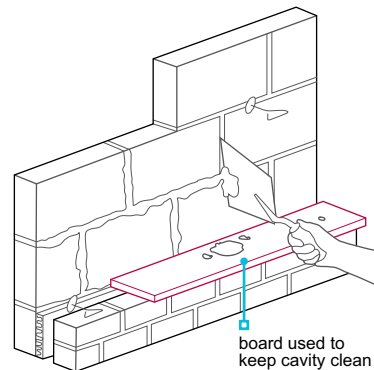
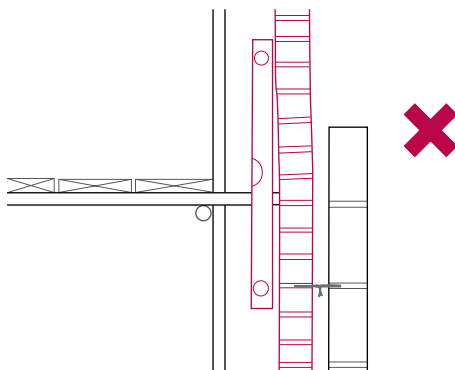


### Construction

The difference in heights between the two leaves of a cavity wall under construction can be up to six block courses, provided the ties are sufficiently flexible to ensure coursing is achieved without breaking the bond. To keep the wall plumb, do not over-reach at changes of lift; wait for the next scaffolding lift.

Cavities should be constructed so that:

- they are uniform and in accordance with the design, including wall tie specification and cavity width
- mortar is struck from all joints as work proceeds
- cavity trays and wall ties are clear of droppings and debris
- mortar droppings are removed
- where cavity insulation is used, mortar droppings are removed from the top edge
- where partial cavity insulation is used, it is against the inner leaf of the cavity.



### Openings

Masonry may be built around either:

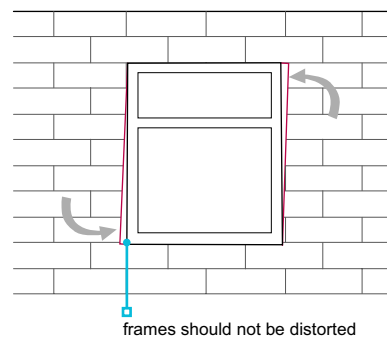
- the frame in-situ, or
- a profile or template to enable the frame to be fitted later.

Openings should be the correct size, square and:

- brickwork should butt closely against the frame
- the frame should not be distorted by forcing bricks against the jamb.

When window and door frames are built-in, they should be fixed with:

- frame cramps
- proprietary cavity closers, or
- plugs and fixings.

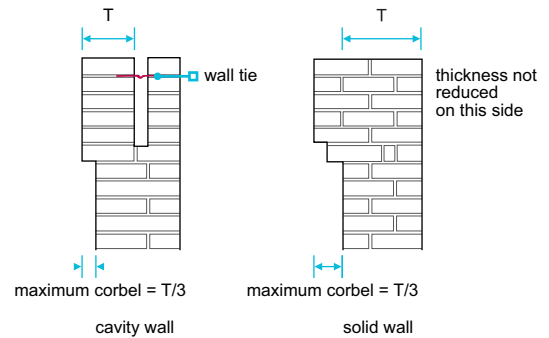




### Corbelling

Where reinforcing is used, corbels should be designed by an engineer in accordance with Technical Requirement R5.

Where courses are corbelled outwards in ordinary masonry, one above another; the extent of corbelling should not exceed that shown in the diagrams on the right.



### Chasing for services

Chases should:

- not be cut with impact power tools, as they can damage the wall
- not be cut into hollow blocks unless specifically permitted by the manufacturer
- be cut with care
- be limited to 1/6 of the depth of the leaf where horizontal
- be limited to 1/3 of the depth of the leaf where vertical.

### Protection of ancillary components

Table 4 contains guidance for a selection of ancillary components for use in buildings up to three storeys in height, in a non-aggressive environment.

**Table 4:** Protection of ancillary components

Product type	EN 845 ref <sup>(1)</sup>	Material/coating specification (the zinc coating masses are for one surface)
Wall ties, tension straps and hangers conforming to BS EN 845-1	1	Austenitic stainless steel (molybdenum chrome nickel alloys)
	3	Austenitic stainless steel (chrome nickel alloys)
	8 or 9	Zinc coated (940g/m <sup>2</sup> ) steel wire or component
Tension straps and hangers conforming to BS EN 845-1 (internal uses <sup>(2)</sup> )	10	Zinc coated (710g/m <sup>2</sup> ) steel component
	11	Zinc coated (460g/m <sup>2</sup> ) steel component
	12.1 or 12.2	Zinc coated (300g/m <sup>2</sup> ) steel strip or sheet with organic coating over all outer surfaces of finished component
	13	Zinc coated (265g/m <sup>2</sup> ) steel wire
	14	Zinc coated (300g/m <sup>2</sup> ) steel strip or sheet with all cut edges organic coated
	15	Zinc pre-coated (300g/m <sup>2</sup> ) steel strip or sheet
	16.1 or 16.2	Zinc coated (137g/m <sup>2</sup> ) steel strip or sheet with organic coating over all outer surfaces of finished component
	17	Zinc pre-coated (137g/m <sup>2</sup> ) steel strip with zinc coated edges
Lintels conforming to BS EN 845-2	L3	Austenitic stainless steel (chrome and nickel alloys)
	L10	Zinc coated (710g/m <sup>2</sup> ) steel component
	L11.1 or L11.2	Zinc coated (460g/m <sup>2</sup> ) steel component with organic coating over all outer surfaces of finished component
	L12.1 or L12.2	Zinc coated (300g/m <sup>2</sup> ) steel strip or sheet with organic coating over all outer surfaces of finished component
	L16.2	Zinc coated (137g/m <sup>2</sup> ) steel strip or sheet with organic coating over all outer surfaces of finished component
Lintels conforming to BS EN 845-2, where used with a separate DPC	L11	Zinc coated (460g/m <sup>2</sup> ) steel component
	L14	Zinc coated (300g/m <sup>2</sup> ) steel strip or sheet with all cut edges organic coated
	L16.1	Zinc coated (137g/m <sup>2</sup> ) steel strip or sheet with organic coating over all outer surfaces of finished component
Bed joint reinforcement conforming to BS EN 845-3	R1	Austenitic stainless steel (molybdenum chrome nickel alloys)
	R3	Austenitic stainless steel (chrome nickel alloys)

#### Notes

- 1 Material/coating reference in accordance with the relevant part of BS EN 845.
- 2 These products are not suitable for use in contact with the outer leaf of an external cavity wall or a single leaf cavity wall.

Components in contact with, or embedded in, an inner leaf which is damp or exposed to periodic wetting (e.g. below the DPC) should be protected in the same way as components in contact with, or embedded in, an outer leaf.

**Lintels** 6.1.12

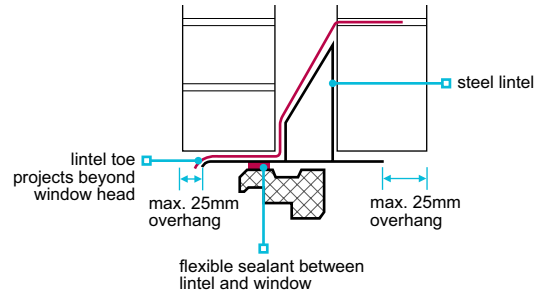
Also see: Chapter 6.5 and BRE Report 'Thermal insulation: avoiding risks'

**Lintels, and supporting beams, shall be installed correctly, safely support the applied loads and be of the type and dimensions appropriate to their position within the structure. Issues to be taken into account include:**

- a) thermal insulation and condensation
- b) durability and resistance to water entering the home
- c) placing lintels.

Concrete, steel and reinforced brickwork are acceptable materials for use as lintels. Timber lintels should not be used, unless:

- protected from weather
- they do not support masonry or other rigid or brittle materials.



Lintels should:

- comply with BS EN 845-2 'Specification for ancillary components for masonry', where steel or concrete
- be designed in accordance either with Technical Requirement R5 or the manufacturer's recommendations
- be provided where frames are not designed to support superimposed loads
- be wide enough to provide adequate support to the walling above
- not have brickwork or masonry which overhangs more than 25mm
- have cavity trays where they are specified in the design
- have padstones and spreaders provided under the bearings, where necessary
- not have point loads applied before the manufacturer's requirement of fully bedded brickwork is met (this is to avoid overstressing).

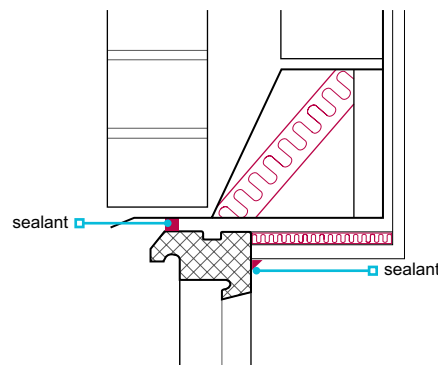
Lintels should extend beyond the opening (at each end) by the minimum lengths shown in Table 5.

**Table 5:** Lintel bearing

Span (m)	Minimum bearing length (mm)	
	Simple lintel	Lintel combined with cavity tray
Up to 1.2	100	150
Over 1.2	150	150

Where steel lintels are used:

- the manufacturer's recommendations for providing adequate fire resistance should be followed, particularly to the lower steel flange
- the inner and outer leaf should be built up together to avoid twisting the lintel flange
- the difference in height between the leaves should not exceed 225mm.



**Thermal insulation and condensation**

The risk of condensation at potential cold bridges, such as reveals and soffits, increases as the level of wall insulation increases. To avoid cold bridging:

- wall insulation should abut the head of the window frame
- insulation should be provided at the underside of the lintel, unless the manufacturer produces an alternative.

In England and Wales, account should be taken of Accredited Details.

**Durability and resistance to water entering the homes**

Cavity tray/damp proof protection should be provided:

- over all openings, either combined as part of the lintel or separate
- where the outer leaf is fairfaced masonry or where full-fill insulation is used, all cavity trays (separate or combined) should have stop ends.

Separate cavity tray protection should be provided when corrosion protection to the lintel is inadequate, or the shape of the lintel is unsuitable, such as when:

- the profile of the lintel does not form a cavity tray
- steel lintels in external walls have material/coating in accordance with L11, L14 and L16.1, see Table 4.

In Scotland, Northern Ireland, the Isle of Man and areas of severe or very severe exposure to driving rain, a separate cavity tray should be provided over all lintels.

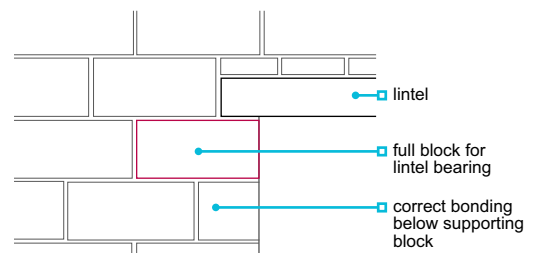
Lintels should be:

- austenitic stainless steel where used in aggressive environments, e.g. coastal sites
- located and sized so that the external edge of the lintel projects beyond, and therefore offers protection to, the window head.

### Placing lintels

The design should be checked and lintels should:

- be an appropriate size for the opening and the end bearings (at each end)
- have padstones where required, e.g. for long spans
- be installed level on a solid bed of mortar (not soft or non-durable packing)
- be set out to ensure that lintels bear on a full block
- not have brickwork or masonry which overhangs more than 25mm.



Concrete floor units or other heavy components which bear on lintels should be positioned carefully to avoid damage or shock load.

### Suitable materials for mortar <sup>6.1.13</sup>

**Materials used for mortar should comply with the appropriate requirements and standards.**

Relevant standards include:

BS EN 197	Cement. Composition, specifications and conformity criteria for common cements
BS 4027	Sulfate-resisting Portland cement
BS EN 197 or BS EN 413	Masonry cement
BS EN 459	Lime
BS EN 998	Ready-mixed mortar
BS EN 934	Air entraining and set retarding admixtures
BS EN 12878	Pigments for colouring mortars

### Mortar <sup>6.1.14</sup>

*Also see: Chapter 3.2*

**Mortar shall be of the mix proportions necessary to achieve adequate strength and durability and be suitable for the type of masonry. Issues to be taken into account include:**

- a) sources of sulfate
- b) admixtures and additives
- c) preparing mortar
- d) joints.

Unless recommended otherwise by the brick manufacturer, the mixes in Table 6 should be used for clay bricks. In the case of concrete or calcium silicate bricks, particular attention should be paid to the manufacturer's recommendations.

**Table 6:** Mortar mixes using ordinary Portland or sulfate-resisting cements

Location		Recommended cement:lime:sand mix	Recommended cement:sand mix with air entraining plasticiser	Recommended masonry cement:sand mix	Mortar designation to BS EN 1996-1-1
General wall area above the DPC	In areas of severe or very severe exposure – high durability	1:½:4½	1:3½	1:3	(ii)
	Other exposure categories – general use	1:1:5½	1:5½	1:4½	(iii)

**Table 6 (continued):** Mortar mixes using ordinary Portland or sulfate-resisting cements

Location		Recommended cement:lime:sand mix	Recommended cement:sand mix with air entraining plasticiser	Recommended masonry cement:sand mix	Mortar designation to BS EN 1996-1-1
Below DPC level and in chimney stacks	High durability	1:½:4½	1:3½	1:3	(ii)
Cappings, copings and sills	Low permeability	1:0 to ¼:3	–	–	(i)

Air-entraining plasticiser can be incorporated in the following general use and high durability mortars:

- 1:1:5½, cement:lime:sand, or
- 1:1:4½, cement:lime:sand.

**Retarded mortar**

Retarded mortar and most premixed mortars can be used over a longer period of time than site-mixed, cement:lime:sand mortars. When using retarded mortar:

- follow manufacturer’s recommendations and timescales
- do not use it beyond the time for which it is effective
- protect it against freezing prior to use
- temporary bracing of larger walls, e.g. at gable peaks and long walls, may be necessary due to delayed setting times.

**Sources of sulfate**

Mortar is vulnerable to deterioration by sulfates, especially when masonry is saturated for long periods of time. Clay bricks contain soluble sulfate (S1 designations have no limit on their sulfate content) and so a suitable mortar should be used.

To reduce risk, sulfate-resisting Portland cement to BS 4027 should be used:

- below the DPC level when sulfates are present in the ground
- when there is a high saturation risk (examples below).
- when clay bricks (F2,S1 and F1,S1 to BS EN 771) are used

High saturation risk situations are:

- below the DPC
- areas of severe or very severe exposure to driving rain
- parapets
- retaining walls
- freestanding walls
- rendered walls
- chimney stacks.

**Admixtures and additives**

Admixtures should:

- only be used where authorised
- not contain calcium chloride
- be dosed and used in accordance with the manufacturer’s recommendations.

Mortars containing an air-entraining plasticiser are more resistant to freeze and thaw damage when set, but do not prevent freezing before the mortar is cured.

White cement to BS EN 197 and pigments to BS EN 12878 may be used, but pigments should not exceed 10% of the cement weight, or 3% where carbon black is used.

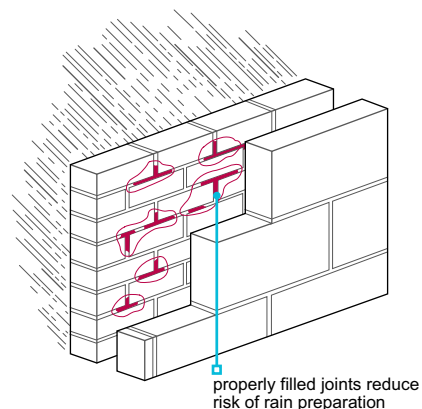
**Preparing mortar**

When preparing mortar:

- ensure the mix is appropriate for the use and location
- plant and banker boards should be kept clean
- mixers should be kept clean to operate efficiently
- the colour should be consistent.

When laying bricks and blocks:

- mortar which has started to set should not be retempered
- they should have a solid mortar bedding and fully filled perpend, to reduce the risk of rain penetration and dampness in the wall.



### Joints

Jointing is preferable to pointing because it leaves the mortar undisturbed. Struck (or weathered) and bucket handle joints are preferable for external walls. Unless the design states otherwise, only bucket handle or weathered joints should be used.

Recessed joints should not be used where:

- bricks are not frost-resistant, e.g. clay F1,S1 or F1,S2 to BS EN 771, unless the brick manufacturer has confirmed their use for that particular location in writing
- the home is built on steep sloping ground, facing open countryside or within 8km of a coast or large estuary
- bricks are perforated closer than 15mm to the face
- there is no reasonable shelter from driving rain, e.g. from buildings or groups of trees within 50m and of similar height to the home
- the cavity is to be fully filled with cavity insulation.

### Render <sup>6.1.15</sup>

*Also see: Chapter 3.3*

**The surface to which render is applied, shall be appropriately constructed and satisfactorily resist the passage of moisture.**

Walls to be rendered should be constructed in accordance with the relevant parts of this chapter, including provision of damp-proofing in accordance with Clause 6.1.17, and Chapter 6.11 'Render'.

### Cladding <sup>6.1.16</sup>

*Also see: Chapter 3.3 and 6.2*

**Cladding shall satisfactorily resist the passage of moisture and be of the quality, type and dimensions required by the design. Issues to be taken into account include:**

- |  |                                    |
|--|------------------------------------|
| a) masonry cladding to framed structures | d) materials for cladding          |
| b) joints                                | e) vertical tile or slate cladding |
| c) moisture barriers                     | f) stone veneer cladding.          |

#### Masonry cladding to framed structures

Allowance should be made for differential movement between cladding and the frame. The following precautions should be taken to prevent buckling and fracturing of masonry panels:

- Flexible movement joints should be provided at the underside of each horizontal support member.
- The masonry outer leaf should have a minimum two-thirds of its width supported securely by the concrete frame or a metal angle.
- Vertical movement joints should be provided at corners.
- The inner leaf should be adequately tied to the structural frame.

### Joints

Joints between claddings and adjacent materials should:

- be detailed to be watertight under the particular exposure conditions of the site
- have provision for differential movement, where necessary.

### Moisture barriers

Moisture barriers should be:

- provided between walls of solid masonry and any boarding, slating, tiling or other similar claddings (unless specifically not required for a proprietary cladding)
- roofing underfelt or equivalent.

Vapour control layers, such as polyethylene sheet, are not an acceptable moisture barrier.

**Materials for cladding**

**Table 8:** Materials for cladding

Component	Requirement	Notes
Tiles and slates	BS 402, BS 473, BS 680	Clay tiles for tile hanging, concrete tiles for tile hanging, slates for vertical slating.
Timber boarding	BS 1186	Timber should: <ul style="list-style-type: none"> <li>■ comply with, and be class 3 or better</li> <li>■ be a naturally durable species or pretreated with preservative.</li> </ul>
Underfelt behind cladding	BS 747	Type 1F felt is acceptable as an underfelt behind cladding.
Battens		Battens should be: <ul style="list-style-type: none"> <li>■ of the size specified in the design</li> <li>■ pretreated with preservative.</li> </ul>
Proprietary cladding systems	Technical Requirement R3	

Timber cladding should be in accordance with Chapter 3.3 'Timber preservation (natural solid timber)'.

**Vertical tile or slate cladding**

Vertical tile or slate cladding should:

- have each tile or slate fixed with two nails
- be fixed using aluminium, copper or silicon bronze nails
- be finished with an under-course and tilting batten at the bottom edges.

**Stone veneer cladding systems**

Stone veneer cladding systems should be in accordance with:

- BS 8298 when mechanically fixed
- Chapter 6.9 when used as a brick slip / rainscreen system.
- Technical Requirement R3 when adhesive fixed

**DPCs and cavity trays <sup>6.1.17</sup>**

**DPCs and related components shall be provided to prevent moisture rising or entering the building. Issues to be taken into account include:**

- a) provision of DPCs and cavity trays
- b) stepped cavity trays
- c) parapet details.

**Provision of DPCs and cavity trays**

DPCs and flexible cavity trays should be of the correct dimensions to suit the detailed design.

At complicated junctions, clear drawings and the design should be provided, and preformed cavity trays used.

The following materials are acceptable for use as DPCs:

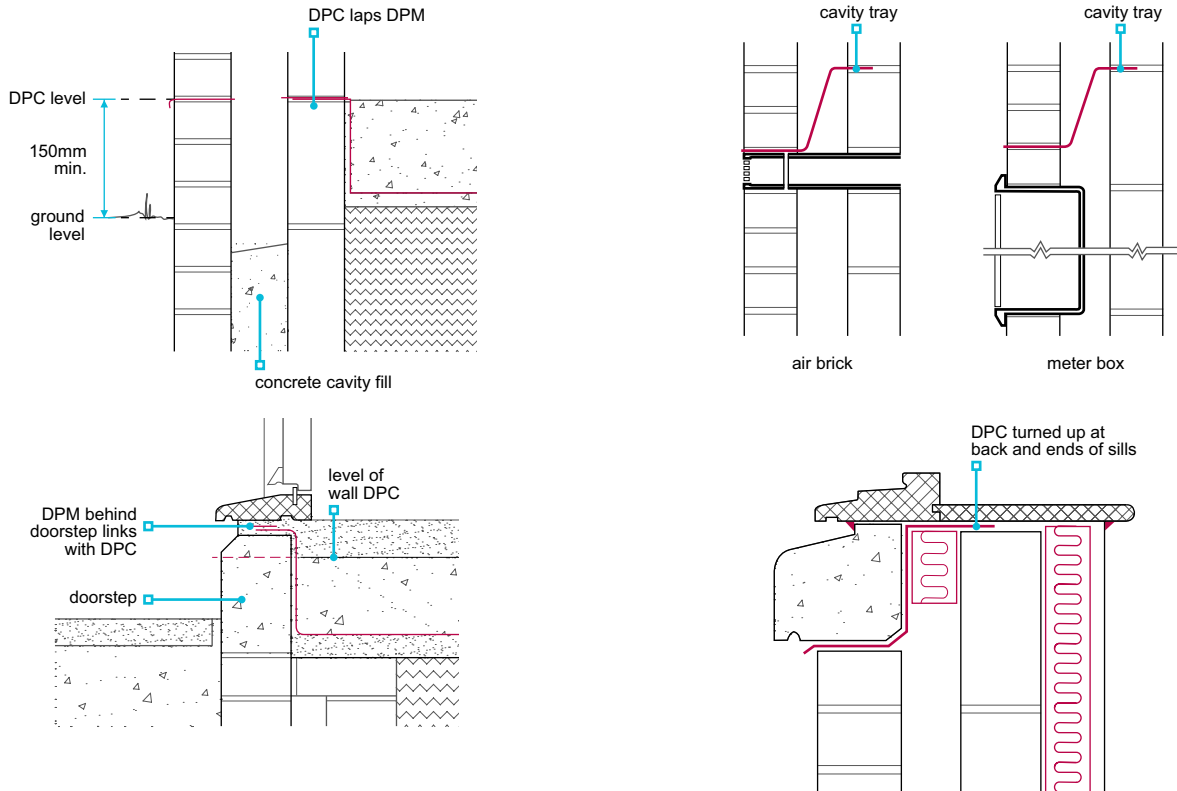
- Bitumen to BS 6398.
- Polyethylene to BS 6515 (except below copings and in parapets).
- Proprietary materials assessed in accordance with Technical Requirement R3.

**Table 9:** Positions where DPCs and cavity trays are generally required

Location	Provision of DPCs and cavity trays
Base of walls, piers, etc.	A DPC should be provided a minimum 150mm above adjoining surfaces and linked with the DPM in solid floors.
Base of partitions built off oversite where there is no integral DPM	The DPC should be the full width of the partition.
Base of wall built off beam, slab, etc.	Detail to prevent entry of damp by driving rain.
Parapets	Beneath coping, and 150mm above adjoining roof surface to link with the roof upstand.
In cavity walls over openings, air bricks, etc.	A cavity tray should be provided to direct any water that enters the cavity to the outside. The cavity tray should fully protect the opening.
At the horizontal abutment of all roofs over enclosed areas and balconies to walls	A cavity tray should be provided 150mm above any adjoining roof or balcony surface. The tray should be lapped over any roof upstand or flashing to ensure water penetrating into the cavity does not enter the enclosed area.
At sloping abutments of all roofs over enclosed areas to cavity walls	Preformed stepped cavity trays should be provided above the roof surface and linked to the roof upstand or flashing to ensure any water penetrating into the cavity does not enter the enclosed area.
Doorsteps	A DPC should be provided behind a doorstep where it is higher than a wall DPC.

**Table 9 (continued):** Positions where DPCs and cavity trays are generally required

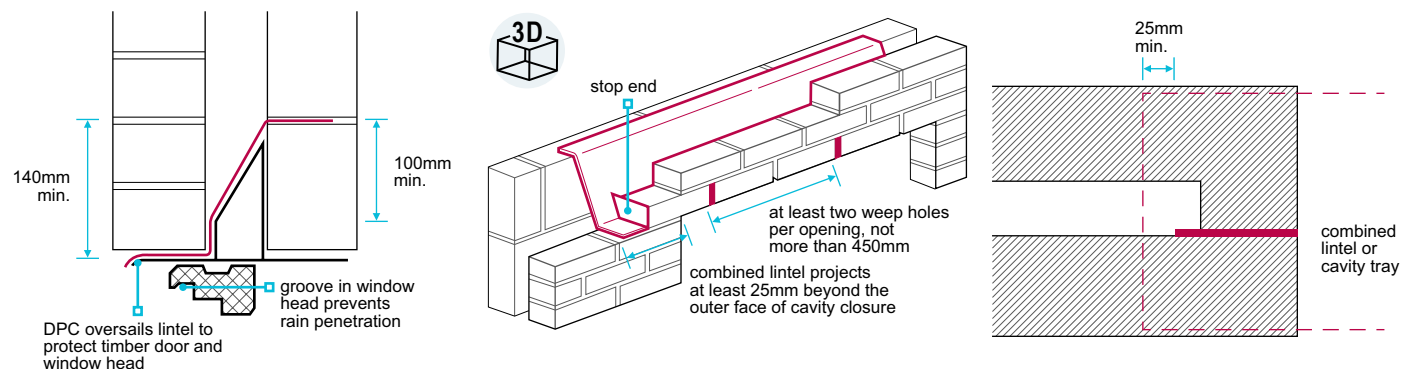
Location	Provision of DPCs and cavity trays
Sills	Where precast concrete or similar sills incorporate joints or are of a permeable material, a DPC should be provided beneath them for the full length and be turned up at the back and the end of the sill.
Jambs in cavity	The reveal should be protected throughout its width by a continuous DPC. The width of the DPC should be sufficient to be fixed to, or overlap, the frame and fully protect the reveal. For severe and very severe exposure conditions, rebated reveal construction or a proprietary closer, suitable for the conditions, should be used.



### Cavity trays

Cavity trays should be provided at all interruptions to the cavity (e.g. window and door openings and air bricks) unless otherwise protected (e.g. by overhanging eaves). Cavity trays should:

- provide an impervious barrier and ensure that water drains outwards
- project at least 25mm beyond the outer face of the cavity closer or, where a combined cavity tray and lintel is acceptable, give complete protection to the top of the reveal and vertical DPC
- provide drip protection to door and window heads
- have a 140mm minimum upstand from the inside face of the outer leaf to the outside of the inner leaf
- be shaped to provide 100mm minimum vertical protection above points where mortar droppings could collect
- be provided where the cavity is bridged by air bricks, etc. and the DPC should extend 150mm beyond each side of the bridge
- where not otherwise protected (e.g. by a roof at an appropriate level), be provided over meter boxes
- be in one continuous piece or have sealed or welded joints.



The upstand part of the cavity tray should be returned into the inner leaf unless it is stiff enough to stand against the inner leaf without support. In Scotland, Northern Ireland, the Isle of Man and areas of very severe exposure to driving rain, the upstand part of the damp proof protection should be returned into the inner leaf of masonry (this does not apply at sloping abutments).

Where fairfaced masonry is supported by lintels:

- weep holes should be provided at a maximum of 450mm intervals
- each opening should have at least two weep holes
- cavity trays or combined lintels should have stop ends.

Where the lintel does not require a DPC, it should:

- have a suitable profile and durability
- give complete protection to the top of the reveal and vertical DPC, where provided.

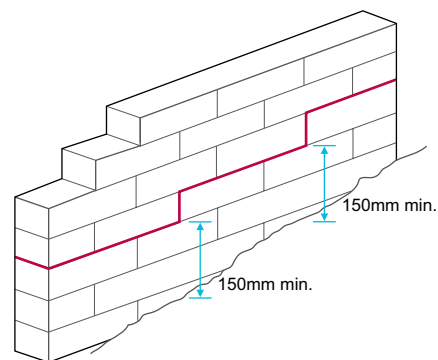
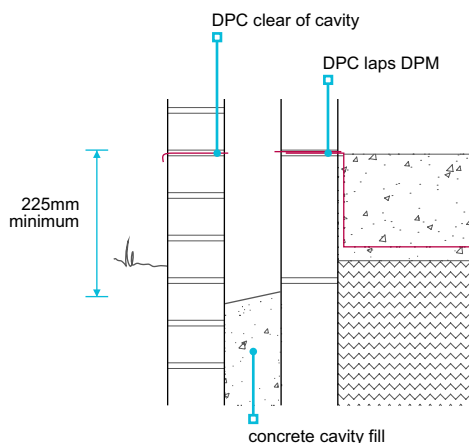
Where the cavity has full-fill insulation, a cavity tray should be used above the highest insulation level, unless the insulation is taken to the top of the wall and is in accordance with the manufacturer's recommendations.

### Horizontal DPCs

DPCs should:

- be the correct width
- lap the DPM where appropriate
- be laid on a surface free from projections which could puncture or adversely affect the DPC material
- be fully bedded on mortar where required by the design, or where the building is over three storeys in height
- at ground level, generally be a minimum of 150mm above finished ground or paving level
- where intended to prevent rising damp, joints should have 100mm lapping, or be sealed or welded
- be used in accordance with the manufacturer's recommendations.

The concrete fill in a cavity wall should stop at least 225mm below the base DPC. This may be reduced to 150mm where special foundations, such as rafts, are used.



Where a jointed or permeable sill is used, a DPC should be:

- placed between the sill and the outer leaf
- turned up at the back and ends of the sill.

At sills where there is:

- a DPC, it should be lapped with the reveal DPC
- no DPC, the vertical DPC should be continued 150mm below the sill level.

Special DPC detailing may be required at accessible thresholds.

### Vertical DPCs

A separate vertical DPC should be provided around openings, extend to the underside of the lintel, and:

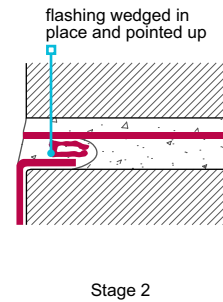
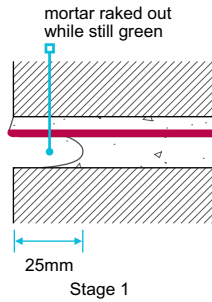
- be of a proprietary material assessed in accordance with Technical Requirement R3, or
- 150mm wide DPC material, nailed to the full height of the frame and protrude 25mm into the cavity.

A fillet joint of sealant should not be considered a substitute for good workmanship or DPCs. However, a bead of mastic should be used around openings.

### Connections with flashings

Where flashings link with DPCs, (e.g. horizontal or preformed stepped cavity trays), 25mm of mortar below the DPC should also be raked out as the work proceeds to allow for the flashing to be tucked in.





### Stepped cavity trays

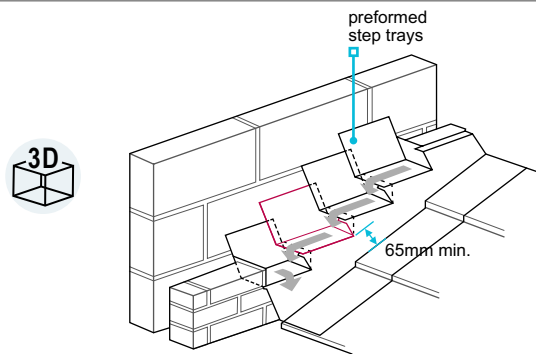
Where the roof abuts at an angle with the wall, preformed stepped cavity trays should be provided.

To minimise the risk of water ingress below the abutment, preformed stepped cavity trays:

- should be provided where a roof abuts a cavity wall above an enclosed area, e.g. an attached garage
- should have two stop ends at the lowest cavity tray and a weep hole to allow water to drain from the cavity
- are not necessary where the roof is not over an enclosed area, e.g. open car ports and open porches.

Preformed stepped cavity trays should be installed in accordance with the manufacturer's recommendations and positioned:

- to suit the dimension of the flashing (which should be in accordance with the manufacturer's recommendations or a minimum width of 65mm)
- so that the stepped cavity tray cannot discharge behind a flashing (where it is necessary to cut bricks or blocks, the bond should be maintained in the following joint).



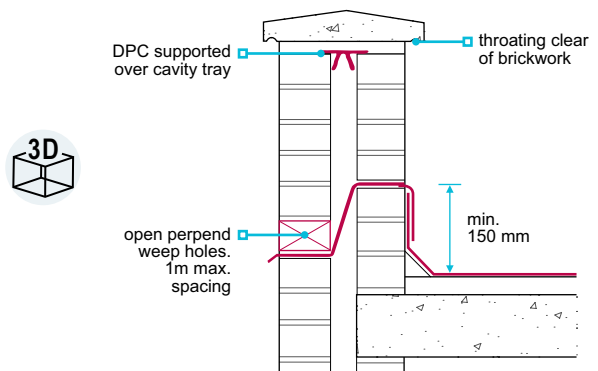
### Parapet details

Parapet walls should have:

- a DPC under the coping, and a DPC tray starting 150mm minimum above the roof
- coping throating which is clear of the brickwork.

DPCs in parapet walls should be:

- supported over the cavity to prevent sagging below copings
- fully bedded in mortar
- specified to achieve a good key with the mortar
- sealed to prevent water seeping through the joints.



**Wall ties** 6.1.18

Wall ties of the correct type shall be installed where required, and be suitable for their intended use and location. Issues to be taken into account include:

- a) position
- b) ties for partial fill insulation.

Wall ties should:

- be in accordance with BS EN 845 or Technical Requirement R3
- be of the type as specified in the design
- be long enough to be embedded a minimum of 50mm into each leaf
- in England and Wales, be stainless steel or non-ferrous
- in Northern Ireland, be stainless steel or non-ferrous ties used where the cavity is fully filled with insulation and 75mm wide or more; in Scotland, galvanised ties may be used
- be spaced above and below the DPC in accordance with Table 10.

**Position**

**Table 10:** Spacing of wall ties

	Maximum horizontal spacing (mm)	Maximum vertical spacing (mm)
General wall area	900	450
Jamb openings, movement joints, etc.	Within 225 of opening	Not more than 300 <sup>(1)</sup>
Top of gable walls	225 (parallel to the top of the wall)	Not more than 300

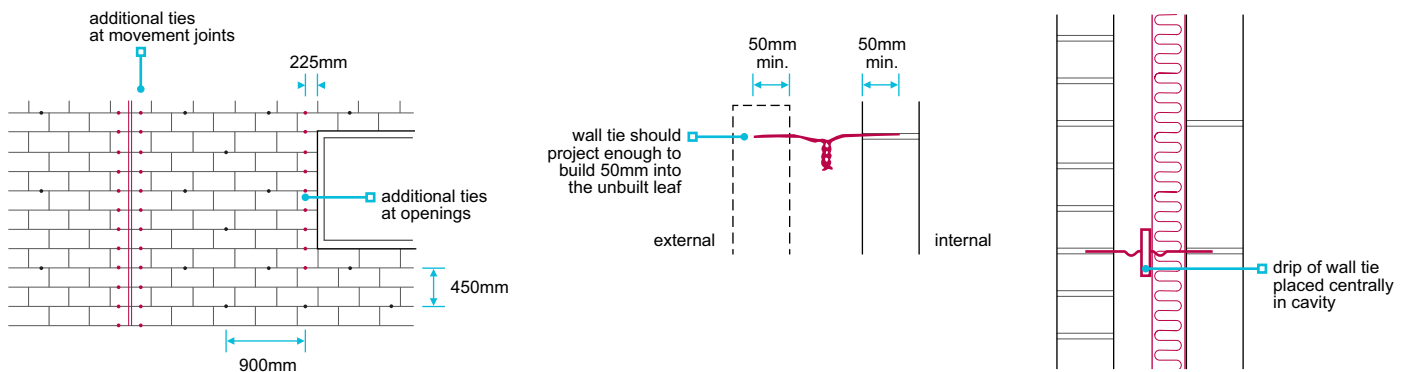
Notes

- 1 The cavity insulation may need cutting to insert the tie.

Water should be prevented from crossing the cavity. Care should be taken to avoid:

- ties sloping down to the inner leaf
- ties having mortar droppings on them.
- drips being off-centre

Cavity walls should be coursed so that the wall tie is level or slopes outwards.



Wall ties should be:

- built in and not pushed into joints
- bedded into the built leaf (by a minimum of 50mm) so that they can have a minimum 50mm bed into the unbuilt leaf
- positioned so that the drip faces downwards.

**Ties for partial fill insulation**

Where partial cavity fill insulation is being used, it should be held against the inner leaf by retaining devices, which may be clipped to the wall ties. Retaining devices should be:

- compatible with the wall ties
- used in accordance with Technical Requirement R3.

Where 1,200mm boards are used with partial fill cavities, the wall ties should:

- be spaced closer to provide adequate support and restraint
- be spaced at 600mm centres in rows, i.e. not staggered.

### Handling materials <sup>6.1.19</sup>

**Materials shall be handled in such a way as to ensure that the construction is neat, clean and undamaged upon completion.**

Materials should be stored properly. Issues to be taken into account include the following:

- Stacks of bricks and blocks should be protected from rain and mud splashes, etc. by covering them with waterproof covers.
- Cement should be stored off the ground and protected from weather.
- Sand should be prevented from spreading and be protected so that it remains clean.

Materials should be handled with care during construction to avoid damage and staining. Chipped or fractured bricks are not acceptable for facework.

Bricks that are tipped on delivery or moved about the site in dumper trucks often have a high degree of wastage. The unloading of all bricks and blocks, especially facing bricks, should be:

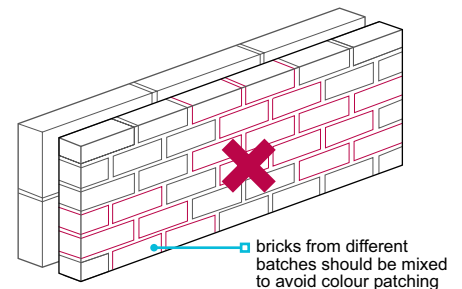
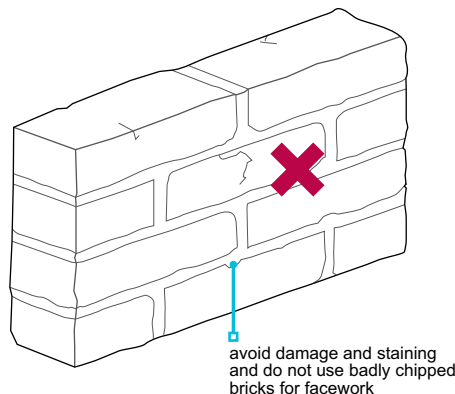
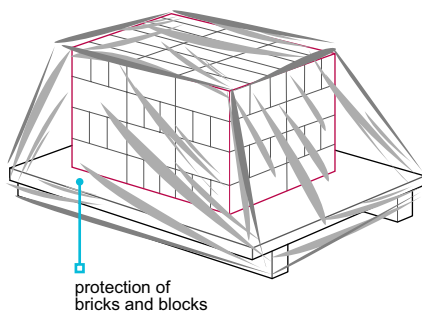
- by mechanical means
- directly onto a firm level surface.

Unless bricks have been blended by the manufacturer, bricks from different batches should be mixed to avoid colour patching.

To reduce the risk of efflorescence, newly erected masonry should be covered. This also prevents the mortar being washed out of the joints by rain and stops masonry becoming saturated. Bricks and blocks that become excessively wet can suffer from:

- staining and efflorescence
- lack of mortar adhesion to mud-stained surfaces.
- increased drying shrinkage, with a greater risk of cracking

The work place should be kept clean to reduce mortar splashes to a minimum. Any accidental mortar smears should be lightly brushed off the face after the mortar has taken its first set.



### Cold weather working <sup>6.1.20</sup>

*Also see: Chapter 3.2*

**Precautions shall be taken to protect walls from damage by frost during construction.**

Freshly laid mortar may fail where it freezes.

The use of air entraining agents in cold weather gives better frost resistance to set mortar but does not aid the set. The use of accelerating admixtures and other admixtures should not:

- be relied on as an anti-freeze precaution
- contain calcium chloride.

Ensure the setting times of additives are checked and adhered to in accordance with the manufacturer's recommendations. Cold weather retarders increase setting times.

In cold weather:

- brickwork and blockwork should not be built when the air temperature is below 2°C and falling
- covers should be provided to form a still air space to insulate the wall
- walls should be protected from frost until the mortar has set sufficiently to resist frost damage
- walling damaged by frost will not regain strength and should be taken down and rebuilt when conditions improve.

# External timber framed walls

## CHAPTER 6.2

This chapter gives guidance on meeting the Technical Requirements for external walls of timber framed homes up to seven storeys high, substantially timber framed homes and timber wall panels.

6.2.1	Compliance	01
6.2.2	Provision of information	01
6.2.3	Design and certification	01
6.2.4	Load-bearing walls	01
6.2.5	Fixing the frame	04
6.2.6	Nails and staples	04
6.2.7	Sheathing	04
6.2.8	Differential movement	05
6.2.9	Fire resistance	09
6.2.10	Protection from moisture	09
6.2.11	Timber preservation	11
6.2.12	Vapour control layers	11
6.2.13	Breather membranes	11
6.2.14	Wall ties and fixings	12
6.2.15	Insulation	12



Raising Standards. Protecting Homeowners

### Compliance <sup>6.2.1</sup>

*Also see: Chapter 2.1*

#### External timber framed walls shall comply with the Technical Requirements.

External timber framed walls that comply with the guidance in this chapter will generally be acceptable.

### Provision of information <sup>6.2.2</sup>

#### Designs and specifications shall be produced in a clearly understandable format, include all relevant information and be distributed to all appropriate personnel.

Clear and fully detailed drawings should be available on site to enable work to be carried out in accordance with the design. Design and specification information should be issued to site supervisors, relevant specialist subcontractors and suppliers, and includes the following:

- A full set of drawings.
- Materials specification.
- The position and materials for cavity barriers in accordance with relevant building regulations.
- Fixing schedules.
- Nailing details.
- Manufacturer's recommendations relating to proprietary items.

The fixing schedule should detail every connection which is to be made on site, including those for structural connections, framing, wall ties, breather membranes, sheathing and vapour control layers, and should show as appropriate:

- number and spacing of fixings
- size and type of fixing, including material and corrosion protection
- method of fixing, e.g. skew nailing.

Where wall design relies on plasterboard to take racking forces, the design should:

- clearly define those walls
- include the type and spacing of fixings required.

### Design and certification <sup>6.2.3</sup>

*Also see: [Technical@nhbc.co.uk](mailto:Technical@nhbc.co.uk)*

#### Design of the superstructure shall be checked by an NHBC timber frame certifier.

Homes with a timber frame superstructure require certification confirming that the design has been checked by an NHBC approved timber frame certifier. In addition, the design should be submitted to NHBC when proposed buildings are four storeys or more and the floor joists are solid timber.

The timber frame certifier should:

- be listed on NHBC's list of timber frame certifiers
- be a suitably qualified civil or structural engineer with a minimum of three years' experience in timber frame construction
- not be the designer of the timber frame
- complete and sign a certificate confirming assessment of structural adequacy for each specific project
- provide the registered builder with the completed and signed certificate.

The registered builder should ensure that the completed timber frame certificate is available on site for inspection by NHBC.

Contact NHBC Standards and Technical department:

- if you require contact details of frame certifiers, or
- to apply to become a timber frame certifier.

### Load-bearing walls <sup>6.2.4</sup>

#### Load-bearing timber framed walls shall be constructed to support and transfer loads to foundations safely and without undue movement. Issues to be taken into account include:

- a) timber elements
- b) joints between panels and other elements
- c) positioning of sole plates
- d) packing under sole plates
- e) fixing panels
- f) support of prefabricated chimneys.

#### Timber elements

Load-bearing timber framed walls should be in accordance with BS EN 1995-1-1, and take into account:

- wind loads
- roof loads
- floor loads.

Timber in external framed walls should be:

- a suitable grade in accordance with BS EN 338 and BS EN 14081-1
- dry graded and marked in accordance with BS 4978

Individual timber studs should have:

- a minimum width of 37mm

Narrow or inaccessible gaps between studs which are difficult to insulate should be avoided.

Lintels and cripple studs should be provided at openings in load-bearing panels except where:

- the opening does not affect the stud spacing, or
- supported loads are carried by a rim beam or perimeter joist.

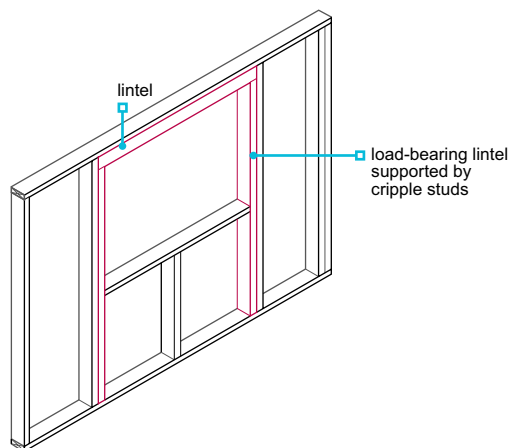
Sheathing and associated fixings should be structurally adequate, and resist racking due to wind and other forces.

Where masonry cladding is used, additional studs may be required at openings to fix wall ties.

Multiple studs should be included to support multiple joists and other point loads, unless otherwise specified by the designer. Where head binders are not provided, joists and roof trusses, including girder trusses and other similar loads, should bear directly over studs.

- I-studs assessed in accordance with Technical Requirement R3.

- a maximum spacing of 600mm, unless other adequate support is provided for wall boards and fixings.



### Joists between panels and other elements

Wall panels should be:

- securely fixed together, and securely fixed to the floor and roof framing
- constructed to prevent buckling.

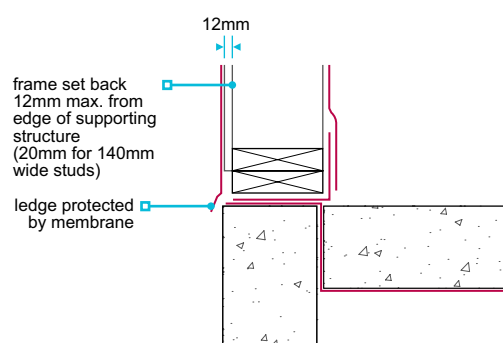
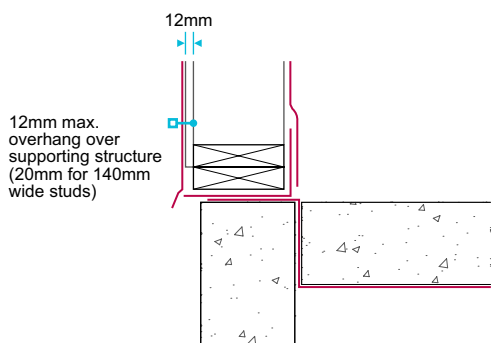
At joints between wall panels, sole plates and head binders should be provided to bind panels together. Joints in sole plates and head binders should:

- occur over a stud
- not coincide with joints between panels.

### Positioning of sole plates

When setting out:

- the substructure should be correctly set out to receive the timber frame
- the timber frame should be checked to ensure that it is erected accurately, both horizontally and vertically
- the load from the frame should be supported as intended in the design
- protection should be provided where ledges form moisture traps.



### Packing under sole plates

Where packing is required to ensure the timber frame or sole plate is level:

- permanent packing should be used for gaps less than 5mm
- grout and mortar should not be used for gaps less than 5mm
- hollow plastic packing with reduced bearing surfaces should not be used
- temporary spacers can remain in place provided they are durable and non-degradable.

Permanent packing should be:

- designed and approved by the timber frame designer to suit the horizontal and vertical loads on the sole plate
- at least the same plan area as the load points, e.g. studs or posts.

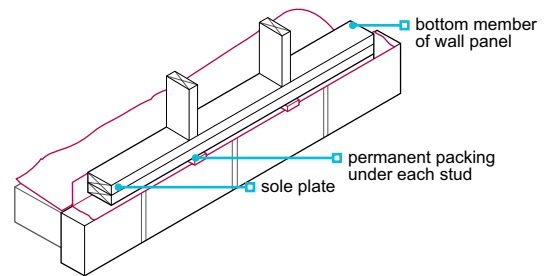
Packing exceeding 20mm should be agreed between the timber frame manufacturer's engineer and NHBC. The following methods are generally acceptable to NHBC for packing up to 20mm.

#### Permanent structural packing under sole plate

The sole plate should be levelled on temporary spacers.

When the first lift construction (including wall panels, first floor structure, or roof structure in a single storey building) has been erected, permanent packing should be placed under the sole plate, which can be:

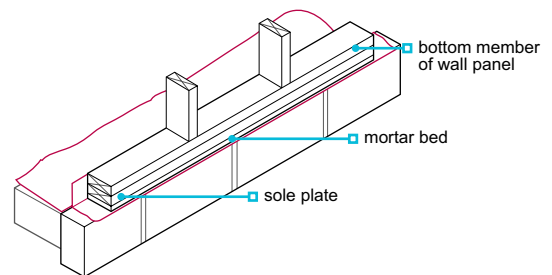
- free-flowing non-shrinkable grout for the full length and width of the sole plate, or
- individual packers placed under each load point, e.g. stud or post.



#### Bedding of the sole plate

The sole plate should be laid and levelled on a continuous bed of mortar prior to the erection of the wall panels.

The bedding should extend the full width of the sole plate. Care is needed to ensure that the bedding is not disturbed during the fixing of the sole plate.

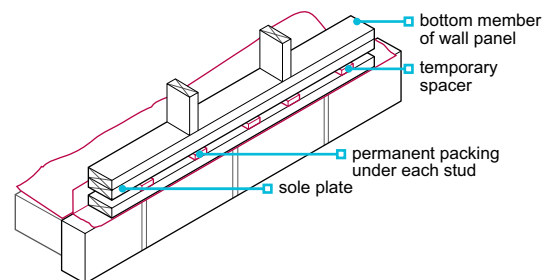


#### Double sole plate 'sandwich'

The lower sole plate should be fixed to follow the contours of the supporting structure.

The upper sole plate should then be fixed on top and levelled with temporary spacers inserted between the sole plates.

When the first lift construction has been erected, permanent packing should be inserted under each load point, e.g. stud or post. As this method uses an additional sole plate, the extra shrinkage should be taken into account.



### Fixing panels

The wall panels should be adequately fixed to the sole plate so that the frame can resist both lateral and vertical forces.

When fixing panels:

- fixings, including nailed joints and sheathing, should be as scheduled in the design
- they should be securely fixed together, to the floor and to the roof framing
- sole plates and head binders should be provided to bind the panels together.

### Support of prefabricated chimneys

Prefabricated chimneys should be supported by the:

- masonry cladding, or
- the timber frame, including any roof construction supported by the timber frame.

**Fixing the frame** <sup>6.2.5</sup>

**The timber frame shall be suitably fixed to the substructure.**

**Shotfiring**

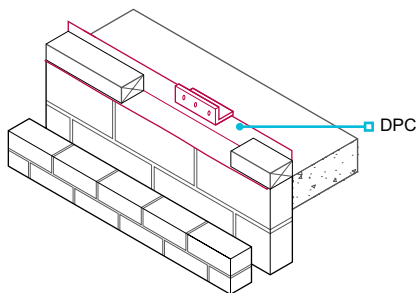
Where shotfiring:

- into masonry, solid concrete blocks should be specified as BS EN 771 with a minimum crushing strength of 7.3N/mm<sup>2</sup> and positioned to receive fixings
- the blocks in beam and block floors should be grouted
- care should be taken not to spall edges of masonry or slabs.

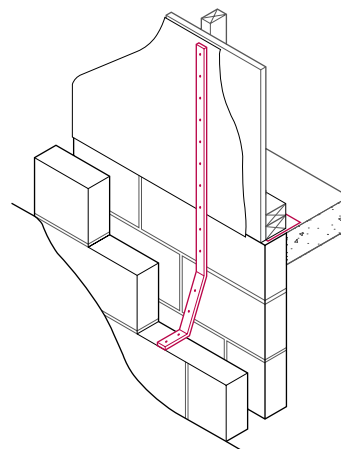
**Anchoring**

When anchoring the frame:

- the sole plate should be adequately anchored to the substructure so that the frame can resist both lateral and vertical forces
- care should be taken to avoid splitting timber plates or damaging the substructure.



Fixing to plate



Fixing to stud

Holding-down devices should be durable, as detailed in the design and manufactured from:

- austenitic stainless steel to BS EN 10088-1, minimum grade 1.4301
- galvanised mild steel with zinc coating to BS EN ISO 1461, minimum coating 940 g/m<sup>2</sup> on each side.

Sole plate anchors within the internal envelope should be galvanised mild steel, minimum coating Z275.

**Nails and staples** <sup>6.2.6</sup>

**Nails and staples shall be durable and of the correct type to provide adequate mechanical fixing.**

Nails for fixing sheathing or timber should be either:

- austenitic stainless steel
- galvanised, or
- sheradized.

Staples for fixing breather membranes should be:

- austenitic stainless steel, or
- other material of similar strength and corrosion resistance.

**Sheathing** <sup>6.2.7</sup>

**Sheathing shall be durable and capable of providing structural resistance to racking**

The following materials are acceptable:

<b>Plywood</b>	BS EN 636 and BS EN 13986 Table 7
<b>Oriented strand board</b>	BS EN 300 type OSB/3 or 4
<b>Moisture-resistant chipboard</b>	BS EN 312 type P5 or P7
<b>Medium board</b>	BS EN 622-3 type MBH.HLS1 or MBH.HLS2
<b>Impregnated soft board</b>	BS EN 622-4 type SB.HLS
<b>Proprietary sheathing materials</b>	Technical Requirement R3 and used in accordance with the assessment.



### Differential movement <sup>6.2.8</sup>

Also see: *Institution of Gas Engineers and Managers (www.igem.org.uk)* and 'Guidance on detailing to accommodate differential movement in timber frame buildings' ([www.uktfa.com](http://www.uktfa.com))

#### Timber structures shall account for differential movement between the timber frame wall and other building elements.

As the timber frame dries out, it will shrink and the overall height will reduce. The extent of the differential movement increases with the number of storeys, and will typically occur between the timber frame and other parts of the construction, including:

- door and window openings
- eaves and verges
- balconies (including Juliet balconies)
- service entries
- openings for drive-throughs
- staircases and lift shaft enclosures (where they are not timber framed)
- the interface of the timber frame with any other construction at each floor level where cladding is fixed to the timber frame.

Movement joints should be provided to accommodate the expected movement. Joints should be detailed to:

- accommodate the expected amount of shrinkage or expansion safely
- provide a weather resistant and durable joint
- be protected by a cover strip where the movement gap/joint is expected to be more than 35mm.

In the absence of project-specific calculations, gaps in accordance with Table 1 should be provided.

**Table 1:** Gap sizes to accommodate differential movement

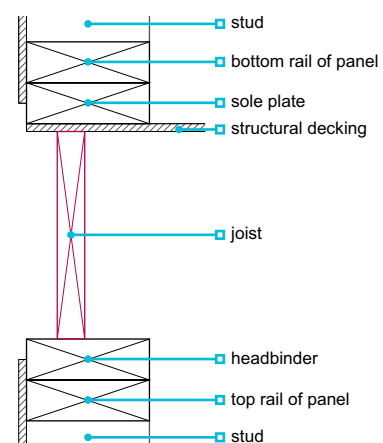
Gap location	Opening and closing gaps (mm)	
	Floor joists	
	Solid timber (mm)	Engineered I-joist (mm)
Eaves/verge	Add 5mm to gap dimension at level below	
Sixth storey	Specialist calculations to be submitted to NHBC <sup>(2)</sup>	61
Fifth storey		53
Fourth storey		45
Third storey		35
Second storey	35	25
First storey	20	15
Ground storey <sup>(1)</sup>	5	5

#### Notes

- 1 Ground storey or lowest level of timber frame.
- 2 Calculations, where required, are to be based on BS EN 1995-1-1.

Table 1 is based on the following:

- The table allows for a 2mm thickness of compressible material in closing gaps. Check the manufacturer's product details.
- Timber components are not saturated and have normal moisture contents at the time of construction, e.g. less than 20% and tight-jointed construction.
- The ground floor is concrete. For ground floors of timber joists, add 15mm for solid timber and 10mm for engineered I-joists
- Timber joist and rim beam/header joist have a maximum depth of 240mm.
- Timber frame floor cross-section is as shown below, with maximum 45mm deep timber plates/binders.
- Single head binder at the eaves. Maximum double sole plates.
- Outer leaf brickwork with expansion rates no greater than 2.5mm per storey.
- Brickwork up to five storeys, with lightweight cladding above five storeys.
- Lightweight cladding – floor level joints must be 15mm for solid timber and 10mm for engineered I-joists.



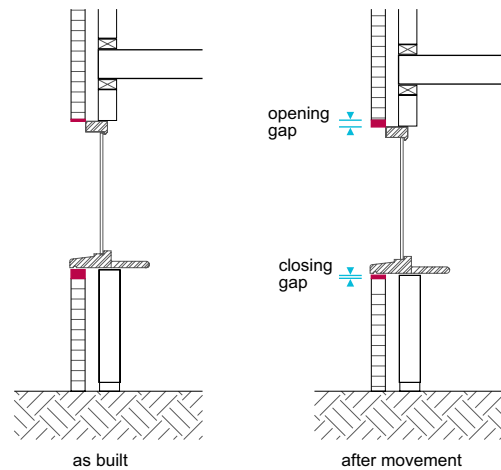
Timber frame construction on which Table 1 is based

Differential movement should be accommodated by the timber frame and by the services affected, especially where they:

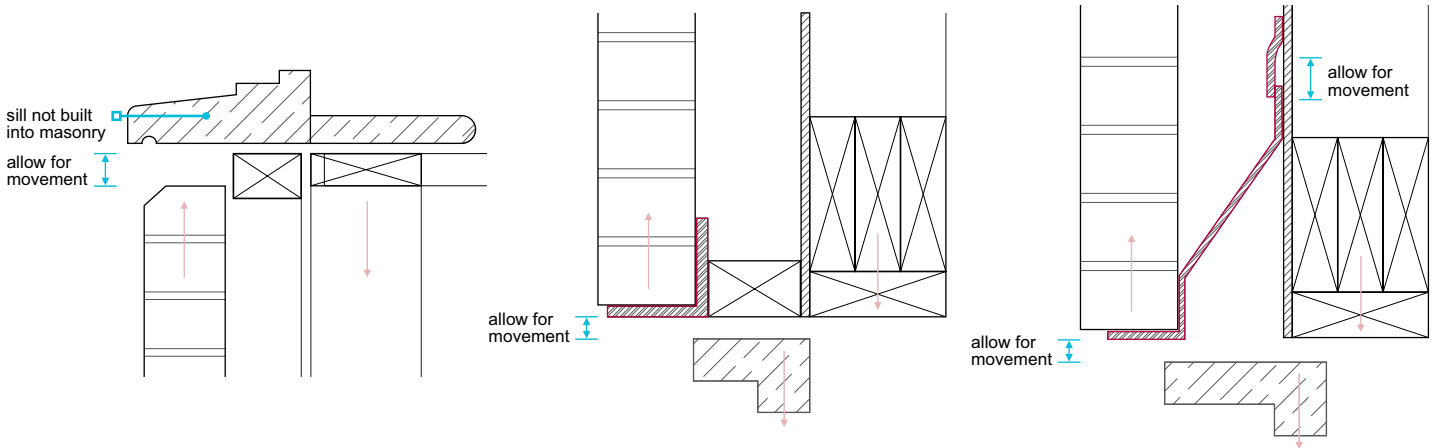
- are within the timber frame construction/envelope
- pass through the envelope.

**Common details**

The following sketches consider downward movement of the timber frame and upward brick expansion, taken as 2.5mm per storey of clay masonry. Cavity trays are omitted for clarity.



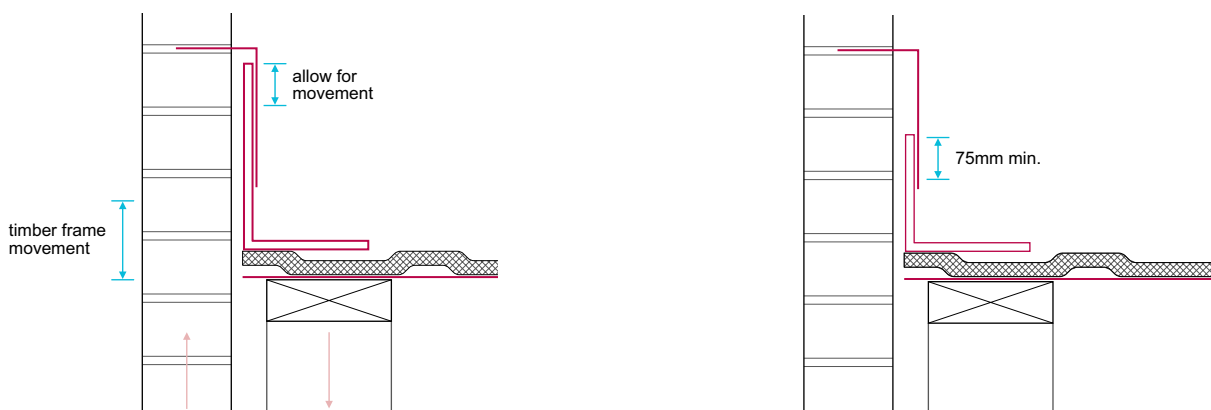
**Window head and sill with masonry cladding**



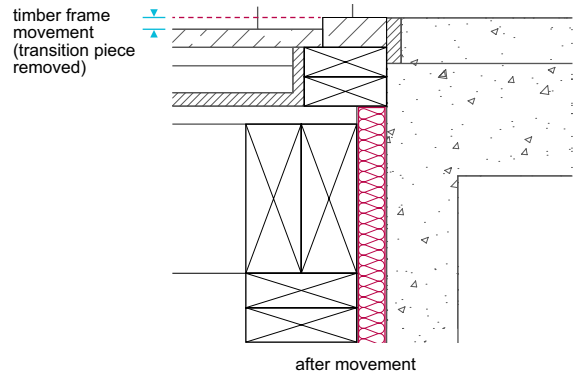
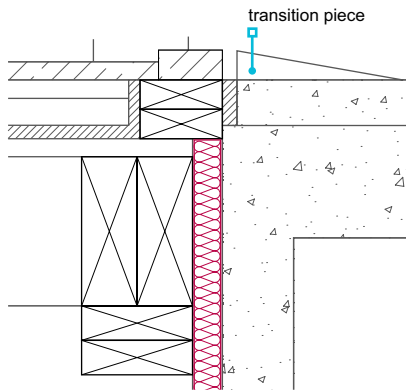
**Window head and sill with lightweight cladding**



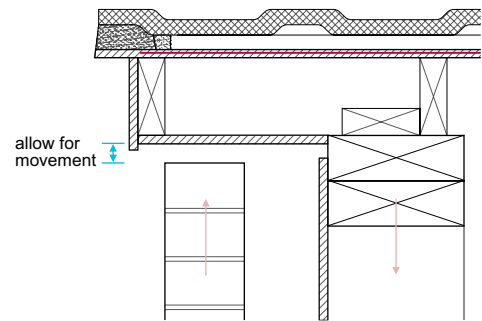
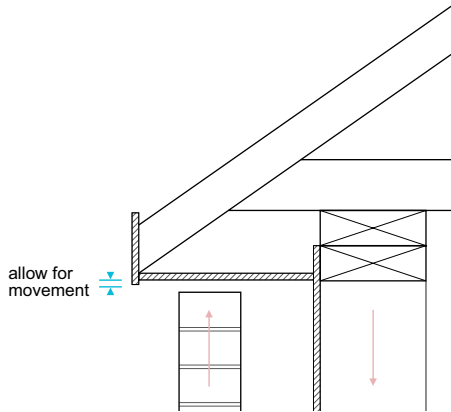
**Roof to vertical abutment**



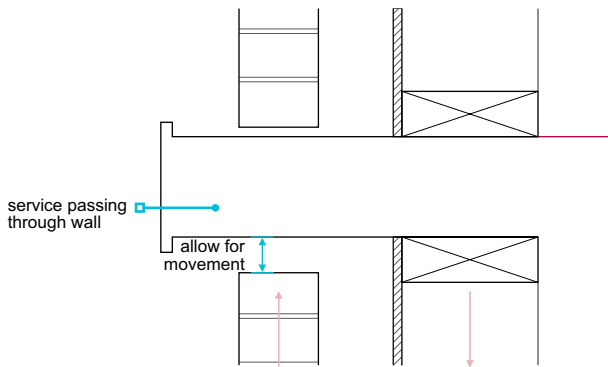
### Timber frame interface with concrete or masonry stairs and common areas



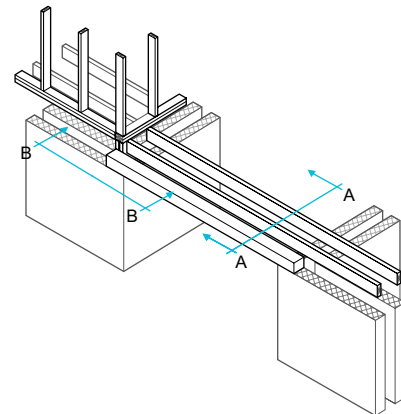
### Eaves and verges



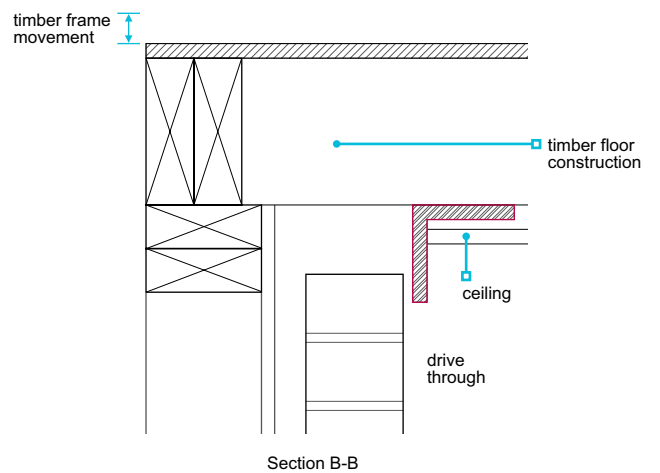
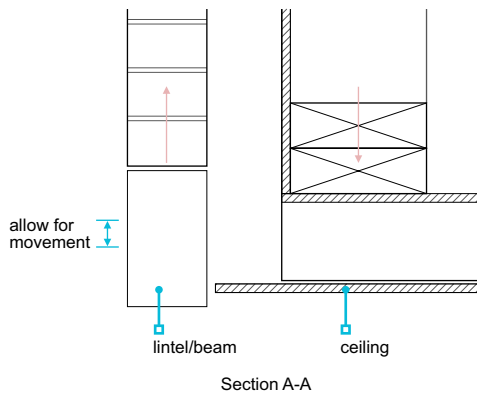
### Services



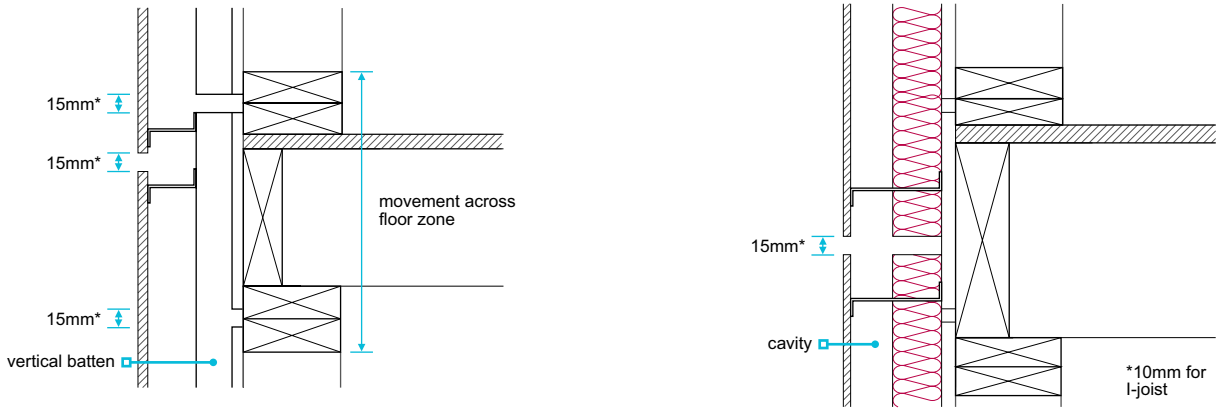
### Drive through



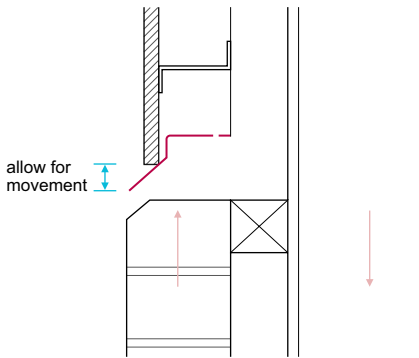
### Drive through



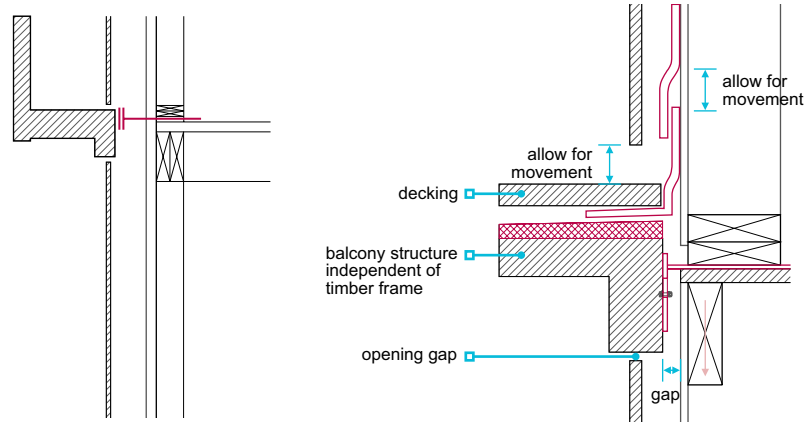
**Lightweight wall cladding – joint at each floor level (with and without insulation in cavity)**



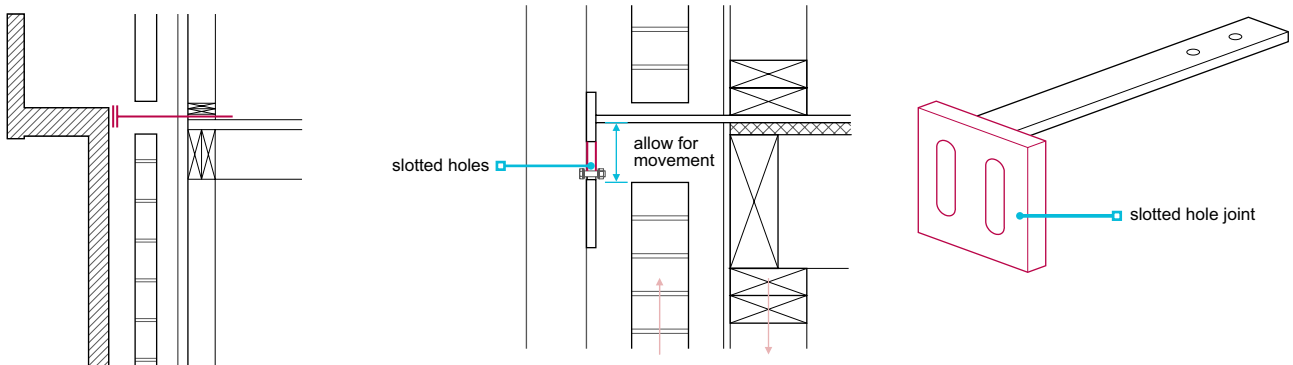
**Lightweight cladding and masonry plinth**



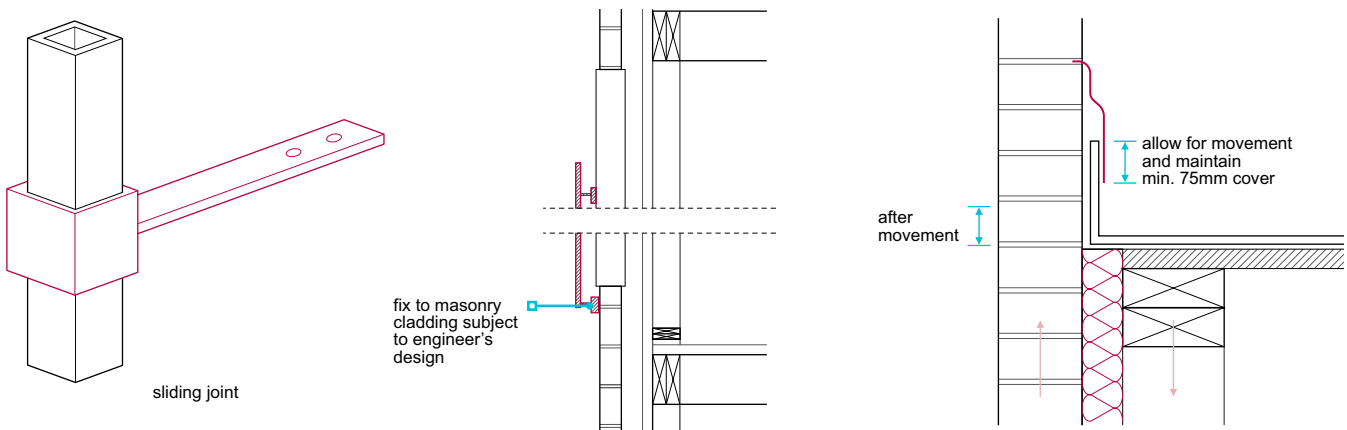
**Balcony abutment – lightweight cladding**



**Balcony abutment – masonry cladding**



**Walls to flat roof abutment**



### Fire resistance <sup>6.2.9</sup>

Also see: 'Fire Prevention on Construction Sites' Construction Federation and Fire Protection Association ([www.thefpa.co.uk](http://www.thefpa.co.uk)) 'Site Safety Strategy' STA '16 Steps to Fire Safety' STA 'Design Guide to Separating Distances' ([www.uktfa.com](http://www.uktfa.com))

**Timber walls and panels shall control and resist the spread of fire and smoke. Issues to be taken into account include:**

- a) cavity barriers and fire stops
- b) services.

All building elements should have adequate fire resistance. Materials in accordance with building regulations are acceptable; other materials should be assessed in accordance with Technical Requirement R3.

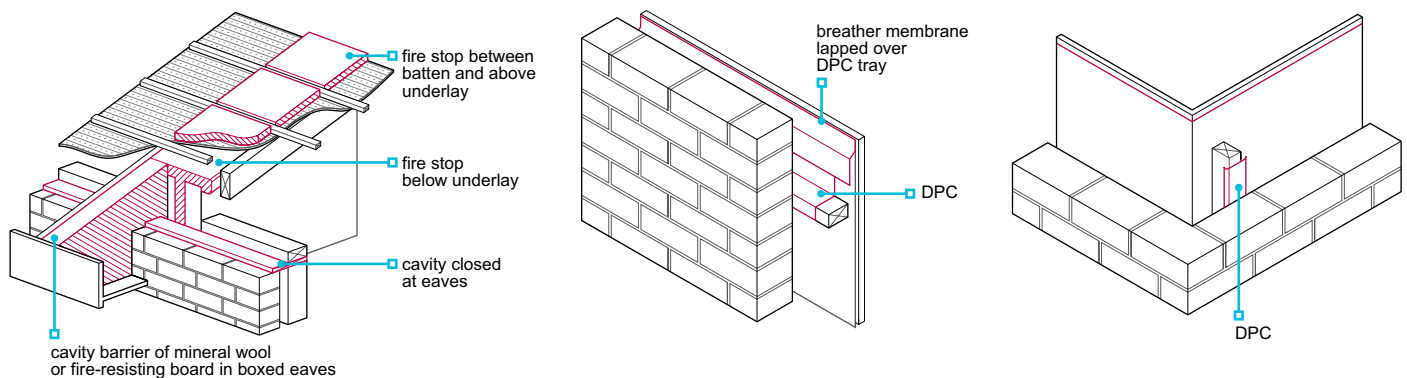
For guidance on the prevention of fire during construction; refer to 'Fire Prevention on Construction Sites' jointly published by the Construction Federation and the Fire Protection Association ([www.thefpa.co.uk](http://www.thefpa.co.uk)), and guidance from the Structural Timber Association ([www.structuraltimber.co.uk](http://www.structuraltimber.co.uk)) under the 'Site Safety Strategy', including the '16 Steps to Fire Safety' and the 'Design Guide to Separating Distances'.

### Cavity barriers and fire stops

The installation, position and materials for cavity barriers and fire stops should be in accordance with the relevant building regulations and the design.

Horizontal and vertical cavity barriers should be protected by DPCs arranged to shed moisture away from the sheathing. Horizontal cavity barriers, except under eaves, should be protected with:

- DPC tray with a 100mm minimum upstand, or
- a polyethylene-encased cavity barrier with a 100mm minimum upstand.



### Services

Only the services shown in the design should be installed in separating walls and:

- service outlets should not impair the fire resistance of floors and walls
- service mains should not pass through separating wall cavities.

Notching or drilling of structural timber members should be carried out as detailed in the design. If these details are not available, the designer should be consulted before such operations are begun.

In Scotland, services are not permitted within a timber framed separating wall.

### Protection from moisture <sup>6.2.10</sup>

Also see: Chapter 6.1 and 6.9

**Timber structures and panels shall be adequately protected from the effects of moisture. Issues to be taken into account include:**

- a) Cavity construction
- b) DPCs.

### Cavity construction

A drained and vented cavity should be provided to reduce the risk of rain penetrating the frame. Cavity widths, measured between the cladding and sheathing, should be in accordance with Table 2.

**Table 2:** Cavity widths

Cladding	Minimum cavity width
Masonry	50mm nominal
Render on backed lathing	25mm nominal
Vertical tile hanging without underlay	No vertical cavity required when a breather membrane is fitted to the sheathing
Other cladding <sup>(1)</sup>	15mm

Notes

1 See Chapter 6.9 'Curtain walling and cladding'.

In areas of very severe exposure to wind driven rain, wall construction should include a 50mm cavity between the sheathing and the cladding and:

- a high performance breather membrane, or
- masonry cladding which is rendered or clad with an impervious material.

Cavities should be:

- vented to allow some limited, but not necessarily through, movement of air
- kept clean, free of obstructions and capable of draining freely.

Where wall areas are divided by horizontal cavity barriers, openings should be provided to each section:

- equivalent to open brick perpend every 1.2m
- below the lowest timber.
- located to prevent the ingress of rain, and

Proprietary perpend ventilators should be used to provide drainage of the cavity.

Horizontal battens, which obstruct the drained and vented cavity, should not be used to support cladding (except tile hanging).

Battens supporting lightweight cladding should be fixed to studs.

Masonry cladding should be constructed in accordance with Chapter 6.1 'External masonry walls'. Proprietary cladding should be fixed in accordance with the manufacturer's recommendations and Chapter 6.9 'Curtain walling and cladding'.

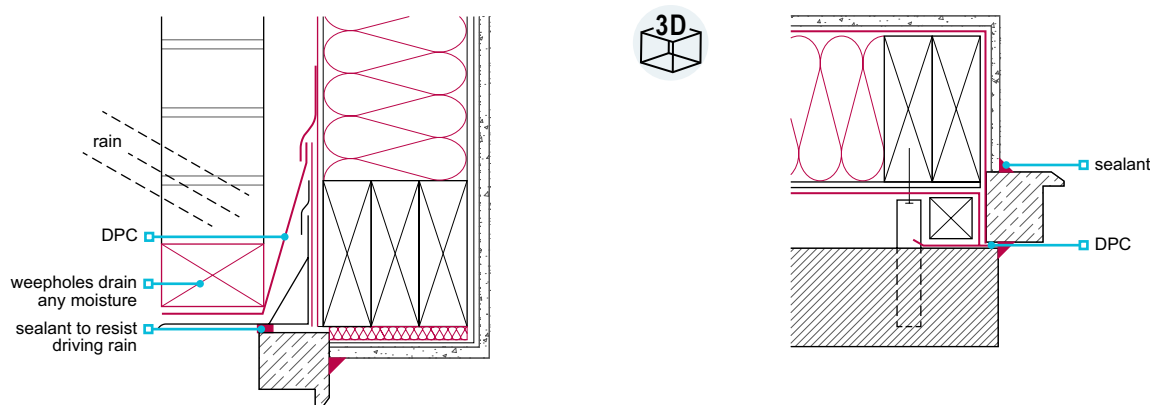
Drained and vented cavities should not contain electricity cables other than meter tails.

**DPCs**

DPCs and trays should be:

- fitted at openings to prevent rain penetration
- installed below the sole plates of ground floor walls and internal partitions.

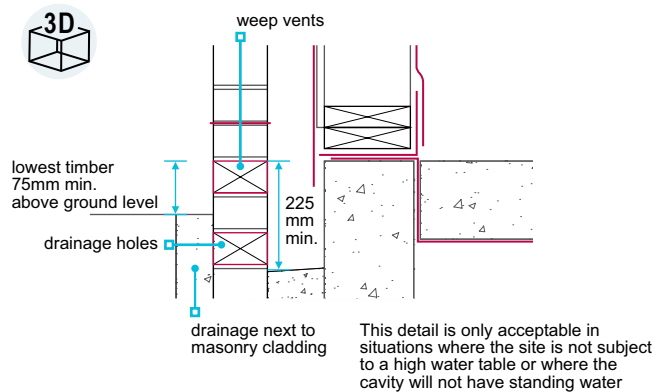
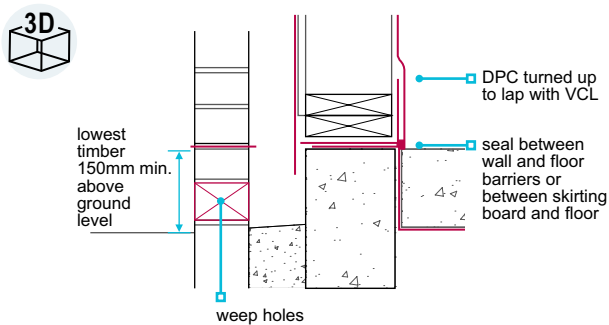
In Northern Ireland, Scotland and the Isle of Man, and in areas of severe or very severe exposure to driving rain, masonry should form a rebate at the reveals of openings to avoid a straight through joint where the frame abuts the masonry.



Cavities should:

- extend below DPC to allow drainage
- be suitably drained to prevent water build-up.
- be kept clear and be vented to allow limited, but not necessarily through, movement of air

The lowest timber should be a minimum of 75mm or 150mm above ground level, depending on the drainage arrangements.



### Timber preservation <sup>6.2.11</sup>

**Timber and timber products shall either be naturally durable or treated with preservative to give adequate resistance against decay and insect attack.**

The following should be treated in accordance with Chapter 3.3 'Timber preservation (natural solid timber)':

- Timber framing.
- Timber cladding.
- I-studs manufactured from timber of durability class 'moderately durable' or lower.

### Vapour control layers <sup>6.2.12</sup>

**Vapour control layers shall be installed correctly and restrict the passage of water from within the home to the timber frame.**

Vapour control layers should be:

- 500 gauge (120 micron) polyethylene sheet, vapour control plasterboard or a product assessed in accordance with Technical Requirement R3
- adequately fixed to the warm side of the insulation and frame (framing timbers should have a moisture content of less than 20%)
- placed to cover the external framed wall area, including rails, studs, reveals, lintels and sills
- fixed at 250mm centres to the top and bottom of the frame, at laps and around openings
- lapped with the DPC
- made good where damage has occurred.

Joints in vapour control membranes should:

- have 100mm minimum laps
- be located on studs or noggings.
- cut with care to avoid displacing the vapour control material.

Where vapour control plasterboard is used, joints should be:

- positioned on studs or noggings
- filled, taped and finished

### Breather membranes <sup>6.2.13</sup>

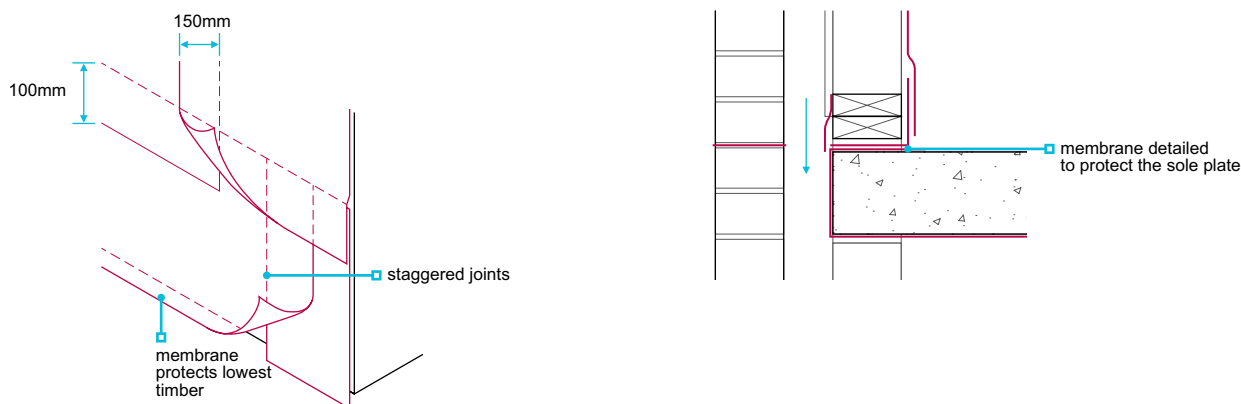
**Breather membranes shall be correctly installed to protect the sheathing and frame from moisture, and allow water vapour from within the frame to pass into the cavity.**

Breather membranes should be:

- vapour resistant to less than 0.6MN/g when tested in accordance with BS 3177 at 25°C and a relative humidity of 75%
- Type 1 to BS 4016 in areas of very severe exposure to wind driven rain, unless impervious or rendered masonry cladding is used
- capable of resisting water penetration
- durable and adequately strong when wet, to resist site damage
- self extinguishing
- fixed so that vertical joints are staggered where possible, and at regular intervals, to prevent damage by wind
- lapped so that each joint is protected and moisture drains outwards and downwards
- lapped so that upper layers are over lower layers to ensure rain runs away from the sheathing
- lapped so that water is shed away from the lowest timber
- lapped with a minimum 100mm overlap on horizontal joints and 150mm on vertical joints
- fixed at a maximum spacing of 600mm horizontally and 300mm vertically
- fixed at a maximum spacing of 150mm around openings
- marked with stud positions for wall tie fixing
- applied using fixings that are in accordance with this chapter
- repaired or replaced before proceeding with the cladding, if damaged.

When bitumen impregnated fibre building board is used and a breather membrane is not specified, the joints of the boards should be closely butted and horizontal joints sealed to prevent water ingress.

When a breather membrane is not required, the bottom frame members should be protected from water in the cavity.



### Wall ties and fixings <sup>6.2.14</sup>

**Wall ties and fixings shall adequately connect the cladding to the timber frame.**

Wall ties and their fixings should be:

- compliant with BS EN 845
- in accordance with the design
- capable of accommodating differential movement
- of the type specified in the design
- of austenitic stainless steel
- fixed to the studs and not the sheathing
- kept clean and free from mortar droppings
- spaced at a maximum of 600mm horizontally and 450mm vertically
- spaced at jambs of openings and at movement joints at a maximum of 300mm vertically and within 225mm of the masonry reveal or movement joint; additional studs may be needed.
- spaced within 225mm of the top of the wall, including at gables
- inclined away from the sheathing so that the slope is maintained following differential movement.

### Insulation <sup>6.2.15</sup>

*Also see: BRE Report 'Thermal insulation: avoiding risks'*

**Insulation shall be correctly installed and provide suitable performance.**

Insulation should be:

- breathable, e.g. mineral wool (rock or glass), or
- assessed in accordance with Technical Requirement R3 for use in timber frame wall panels.

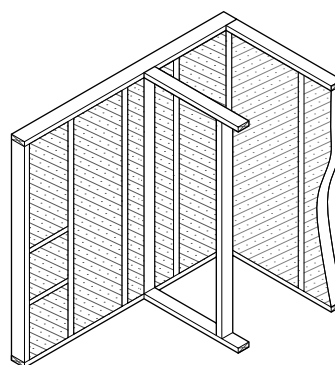
Insulation should generally be placed within the stud void and cover the whole wall area between studs. No gaps should be left:

- at corners
- at junctions with partitions
- against studs or rails
- against noggings
- behind service panels.

In England and Wales, account should be taken of Accredited Details.

Water and heating services within walls should be on the warm side of the insulation.

Where partial fill cavity insulation with a 50mm residual cavity is used, it should be assessed in accordance with Technical Requirement R3 as an integral part of the wall system.





# Internal walls

## CHAPTER 6.3

This chapter gives guidance on meeting the Technical Requirements for internal walls, including:

- separating and compartment walls
- internal partition walls.

6.3.1	Compliance	01
6.3.2	Provision of information	01
6.3.3	Supporting load-bearing internal walls	01
6.3.4	Masonry walls	01
6.3.5	Load-bearing timber walls	03
6.3.6	Fire resistance	04
6.3.7	Sound insulation	05
6.3.8	Partitions: internal non load-bearing	07
6.3.9	Construction of timber partitions	07
6.3.10	Plasterboard	08
6.3.11	Construction of proprietary systems	09
6.3.12	Damp proof courses	09
6.3.13	Components	09



Raising Standards. Protecting Homeowners

### Compliance <sup>6.3.1</sup>

*Also see: Chapter 2.1*

#### Internal walls shall comply with the Technical Requirements.

Internal walls, including separating, compartment and partition walls, which comply with the guidance in this chapter will generally be acceptable.

### Provision of information <sup>6.3.2</sup>

#### Designs and specifications shall be produced in a clearly understandable format, include all relevant information and be distributed to all appropriate personnel.

Design and specification information should be issued to site supervisors, relevant specialist subcontractors and suppliers, and include the following information:

- Wall layout, with all dimensions shown.
- Position and size of openings and lintels.
- Details of junctions, indicating fire stopping where applicable.
- Details of wall constructions and materials, ties and restraints.
- Details of junctions between a separating or compartment wall and a pitched or flat roof.
- Details of pipes and cables where they penetrate walls, including fire-resisting walls.
- Manufacturer's recommendations for assembly and fixing of propriety components.

### Supporting load-bearing internal walls <sup>6.3.3</sup>

#### Loadbearing internal walls shall be adequately supported by foundations.

Load-bearing internal walls should have:

- a foundation, or
- a means of support that transfers loads safely to a foundation.

Foundations should be in accordance with Part 4 of these Standards, including, where applicable, Chapter 4.3 'Strip and trench fill foundations' and Chapter 4.4 'Raft, pile, beam and pier foundations'.

### Masonry walls <sup>6.3.4</sup>

*Also see: Chapters 6.1, 6.4 and 9.2*

#### Internal masonry walls shall be designed to support and transfer loads to foundations safely and without undue movement. Issues to be taken into account include:

- a) structural elements
- b) mortar mix and jointing
- c) workmanship
- d) bonding and tying
- e) lateral restraint
- f) masonry separating walls
- g) lintels and beams.

#### Structural elements

Structural design of masonry walls should be in accordance with BS EN 1996-1-1.

Bricks and blocks should be selected in accordance with their intended use and as recommended in Table 1.

**Table 1:** Bricks and blocks in buildings up to three storeys high

Height of wall	Unit	Minimum compressive strength
One or two storey	Blocks	2.9 N/mm <sup>2</sup>
	Bricks	9.0 N/mm <sup>2</sup>
Lowest storey of a three storey wall, or where individual storeys exceed 2.7m	Blocks	7.3 N/mm <sup>2</sup>
	Bricks	13.0 N/mm <sup>2</sup>
Upper storeys of a three storey wall	Blocks	2.9 N/mm <sup>2</sup>
	Bricks	9.0 N/mm <sup>2</sup>

Where buildings are more than three storeys high, masonry should be designed in accordance with Technical Requirement R5 and the block strength specified in the design.

#### Precast concrete blocks

Concrete blocks should comply with BS EN 771. The maximum load-bearing capacity of the wall should not exceed the recommendations of the manufacturer.

Flue blocks should be in accordance with the manufacturer's recommendations.

**Bricks**

Bricks should comply with the relevant British Standards:

<b>Clay bricks</b>	BS EN 771-1
<b>Calcium silicate bricks</b>	BS EN 771-2
<b>Concrete bricks</b>	BS EN 771-3

When used in a separating wall, masonry should:

- be in accordance with the design information
- provide a suitable level of sound resistance.

**Mortar mix and jointing**

Mortar should:

- be the correct mix and used within two hours, unless it is retarded mortar
- not be re-tempered if it has started to set
- include sulfate-resisting cement where required.

Admixtures, retarded mortars and premixed mortars should be:

- compatible with masonry and other components
- used in accordance with the manufacturer's recommendations.

Air-entraining agents:

- can help reduce frost damage but cannot be used as anti-freeze
- should be carefully measured for each batch and be in accordance with the manufacturer's instructions.

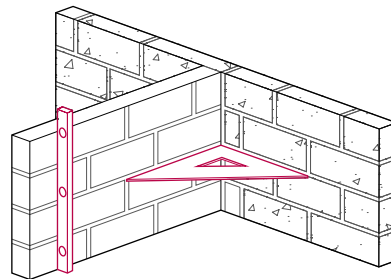
Bricks and blocks should be laid on a full bed of mortar, with perpend solids filled.

Where walls are to be finished with wet plaster, joints should be raked out to a shallow depth to provide a key. For dry lining, mortar joints should be struck off flush.

**Workmanship**

Internal masonry walls and associated works should be:

- constructed in lifts/stages to prevent the distortion of wall panels during construction
- accurately set out
- reasonably plane and true
- plumb, with courses level.

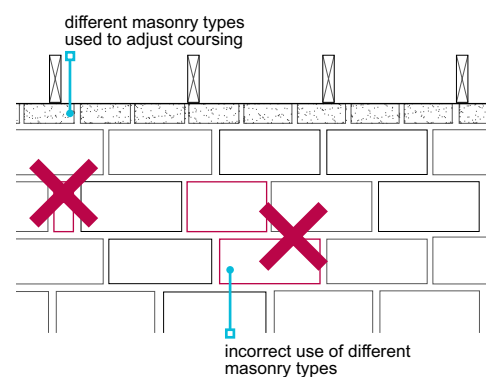
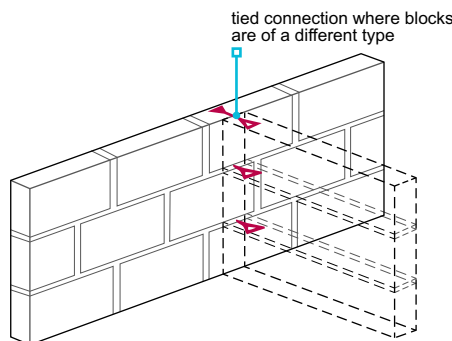
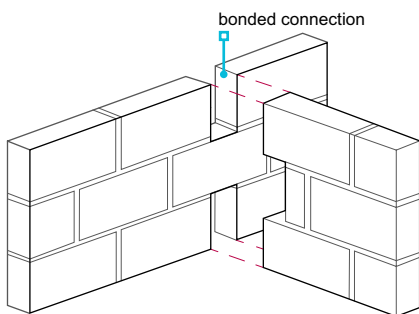


**Bonding and tying**

Internal masonry walls should:

- maintain a regular bonding pattern
- not include bricks or blocks of different types in the same wall, to avoid cracking
- be fully bonded or tied, either with a tooth at alternate courses, or an expanded metal tie (or equivalent) at a maximum vertical spacing of 300mm.

Joist filling should be brick or blockwork, without excessive mortar joints.



### Lateral restraint

Load-bearing masonry walls, including separating walls, should be provided with lateral restraint at:

- each floor level
- ceiling level below a roof.

Restraint straps should be provided to separating walls on each level, at a maximum of 2m centres, when the floor:

- is not on, or near, the same level
- does not provide adequate restraint.

Lateral restraint should be provided in accordance with Chapter 6.4 'Timber and concrete upper floors'.

#### Timber floors

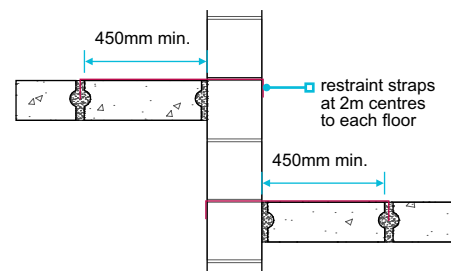
Adequate restraint can be provided by timber floors where joists have a minimum 90mm bearing. Alternatively, restraint should be provided by:

- restraint straps with a minimum 30mm x 5mm cross-section, or
- restraint type joist hangers to BS EN 845-1 with a performance equivalent to restraint straps.

#### Concrete floors

Adequate restraint can be provided by concrete floors that have a minimum 90mm bearing on to the wall. Alternatively, restraint should be provided by:

- restraint straps that are a minimum of 450mm long with the end turned down between a joint in the concrete floor or suitably fixed with screws.



### Masonry separating walls

Both leaves of a masonry cavity separating wall should be tied together to provide structural stability. The type of tie and spacing should limit the sound transmission across the cavity in accordance with building regulations.

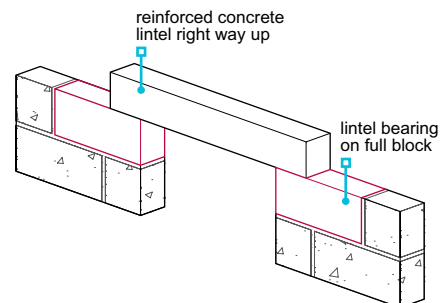
### Lintels and beams

Lintels should be specified according to loads and spans:

- in accordance with manufacturer's recommendations, or
- designed by an engineer in accordance with Technical Requirement R5.

For masonry:

- concrete and steel lintels are suitable
- timber lintels should not be used
- lintels should extend beyond the end of each opening in accordance with Table 2.



**Table 2:** Lintel bearings

Span (m)	Minimum length of bearing (mm)
Up to 1.2	100
Over 1.2	150

Lintels and beams should:

- have padstones where required
- be the correct way up
- bear on a full block, and be level and bedded on a solid bed of suitable mortar
- not have soft or non-durable packing.

### Load-bearing timber walls <sup>6.3.5</sup>

*Also see: Chapter 2.1*

**Internal load-bearing timber walls shall be designed to support and transfer loads to foundations safely and without undue movement. Issues to be taken into account include:**

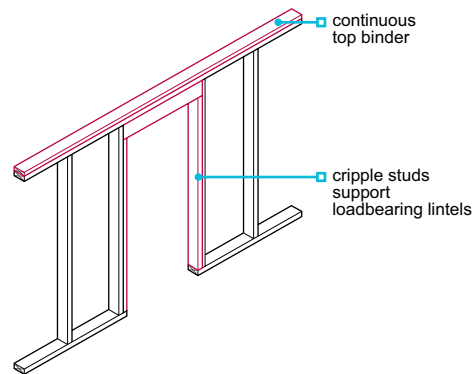
- a) structural elements
- b) timber separating walls
- c) timber quality.

#### Structural elements

Structural design of load-bearing timber walls should be in accordance with BS EN 1995-1-1.

When constructing structural elements:

- individual studs, sills and headplates should be 38mm x 75mm minimum, although larger sizes may be required to achieve an adequate level of fire resistance
- studs should be spaced at a maximum of 600mm centres
- lintel and cripple stud should be provided to each opening, except when the stud spacing is unaffected
- multiple joists should be supported by multiple studs
- framing joints should be secured with a minimum of two nails per joint
- where internal walls are made up from panels, structural continuity should be maintained, e.g. by the use of a continuous top binder.



### Timber separating walls

The type and spacing of wall ties and straps should limit sound transmission across the cavity in accordance with building regulations.

Wall ties should:

- be specified in accordance with the system designer's recommendations
- have a maximum cross-section of 40mm x 3mm
- be fixed below ceiling level
- be spaced a minimum of 1.2m horizontally.

### Timber quality

Timber should be of the appropriate grade, moisture content and size to support the imposed loads.

Structural timber should be of a suitable grade and specified according to the strength classes in BS EN 338, e.g. C16 or C24. When graded to BS 4978:

- the species should be included in accordance with BS EN 1912 or the class strength specified
- BS EN 338 can be used to determine strength class.

Timber should have a maximum moisture content of 20%.

Structural softwood for internal use should be:

- dry graded to BS 4978
- marked 'DRY' or 'KD'.

Timber for walls which are to be dry-lined should be regularised and comply with BS 8212. Finger joints should comply with BS EN 385.

### Fire resistance 6.3.6

*Also see: Chapter 6.2 and 8.1*

**Internal walls shall have adequate resistance to the spread of fire. Issues to be taken into account include:**

- |                         |               |
|-------------------------|---------------|
| a) fire resistance      | c) services   |
| b) typical construction | d) materials. |

The guidance below does not apply to Scotland, and reference should be made to the Technical Handbooks.

### Fire resistance

Internal walls should provide fire resistance in accordance with building regulations.

### Typical construction

Internal walls of hollow or cavity construction (fire-resisting or otherwise) should have cavity barriers installed at:

- the perimeter
- junctions with fire-resisting floors and walls.

Fire-resisting walls should be fire stopped or constructed to resist fire spread at:

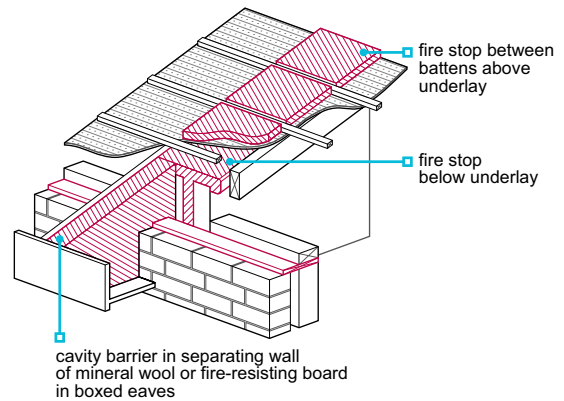
- their perimeter
- junctions with other fire-resisting walls, floors and roofs
- openings for doors and pipes, etc.

Where fire-resisting walls are of:

- masonry construction with a cavity, they should be closed at the top
- timber construction, they should have wire reinforced mineral wool cavity barriers at junctions with floors and ceilings.

At junctions between a separating or compartment wall and a pitched roof or flat roof:

- adequate precautions should be provided to prevent fire spread
- the separating wall should stop approximately 25mm below the top of adjacent roof trusses
- soft packing such as mineral wool should be installed above and below the roofing underlay to allow for movement in roof timbers to prevent 'hogging' of the tiles.



A wire reinforced mineral wool blanket cavity barrier should be provided within boxed eaves and be:

- a minimum 50mm thick
- fixed to the rafter.
- carefully cut to shape to seal the boxed eaves fully

The wall dividing an integral, or attached, garage and the floor above should be designed to act together to provide adequate resistance to fire spread. Where the garage has either no ceiling or there is no floor in the space above, vertical fire separation may be required.

For timber constructions, fire stopping material should be compressible, e.g. mineral wool, to accommodate timber shrinkage without affecting fire stopping.

### Services

Where services such as pipes, cables and ducting pass through fire-resisting walls, penetrations should be fire stopped. Services should not penetrate plasterboard layers of separating walls.

Fire stopping should be:

- in accordance with building regulations and the design information
- completed neatly.

### Materials

Suitable fire stopping materials include:

- mineral wool
- cement mortar
- gypsum plaster
- intumescent mastic or preformed strip
- proprietary sealing systems assessed in accordance with Technical Requirement R3.

### Sound insulation <sup>6.3.7</sup>

*Also see: BS 8212*

**Walls shall be insulated with materials of suitable thickness and density to provide adequate resistance to the transmission of sound. Issues to be taken into account include:**

- sound-resisting construction
- rooms which contain a WC.

### Sound-resisting construction

#### Masonry separating walls

In England and Wales, separating walls may be built in accordance with Robust Details 'Resistance to the passage of sound'.

To maintain sound insulation:

- the correct blocks should be used
- fully fill joints, mortar beds and perpend
- use only approved wall ties
- space wall ties 900mm minimum horizontally and 450mm minimum vertically
- avoid any reduction in the thickness of masonry
- ensure spaces around joists are fully filled with masonry and pointed
- where external cavity walls have blown or pumped insulation, separating walls should be constructed with flexible cavity stops so that insulation cannot enter the cavity
- care should be taken when specifying dry lining, as the thickness of plasterboard layers, and the methods of sealing and fixing, can affect the transmission of sound
- holes, voids and hairline cracks should be avoided or made good, as they can significantly reduce the effectiveness of a sound-insulating wall.

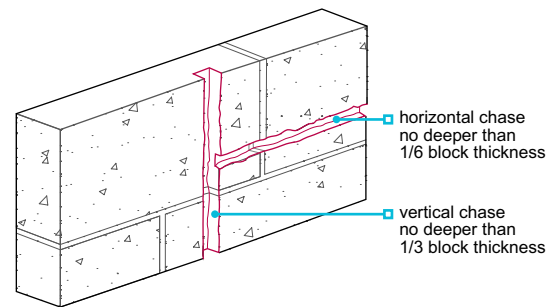
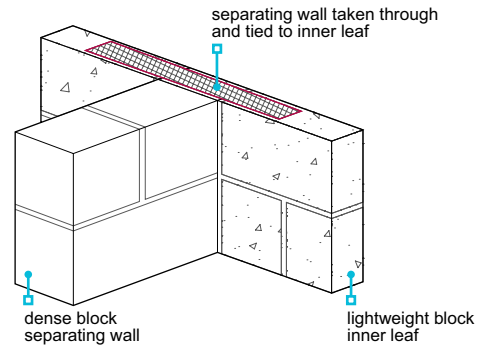
In masonry separating cavity walls and where the cavity is up to 75mm, flexible wall ties should be:

- butterfly type ties, or
- tested to show compliance with building regulations.

Solid separating walls should be taken through the inner leaf of an external cavity wall and tied. Where the same blocks are used for both walls, tooth bonding is acceptable.

Chases can reduce the sound insulation value of a wall and should:

- be cut only where specified in the design
- not be cut using impact power tools where there is a risk of damage
- not exceed 1/6 of the thickness of the single leaf where horizontal
- not exceed 1/3 the thickness of the single leaf where vertical
- not be chased where hollow blocks are used, unless specifically permitted by the manufacturer
- be fully filled with mortar
- have positions of electrical socket outlets staggered on opposite sides of the wall.



**Timber separating walls**

Timber separating walls should not have gaps in the:

- mineral wool quilt
- plasterboard layers
- fire stopping.

**Flanking walls**

The construction of the flanking wall and the position of openings should comply with building regulations.

**Rooms containing a WC**

The guidance below applies in Northern Ireland, Scotland and the Isle of Man. In England and Wales, the construction should comply with building regulations.

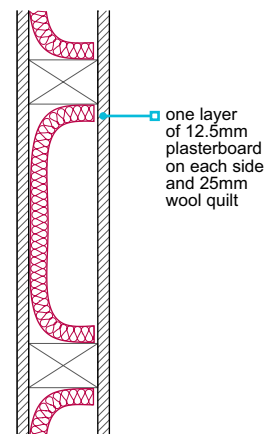
A minimum sound reduction of 38dB (100-3150Hz) when tested in accordance with BS EN ISO 140-4 is required between rooms that include a WC and:

- living rooms
- dining rooms
- studies
- bedrooms, except where the WC is ensuite.

**Timber studwork**

Timber studwork should be used with one of the following on each side:

- two layers of 12.5mm plasterboard
- one layer of 12.5mm plasterboard and 25mm mineral wool between the studs
- one layer of 9.5mm plasterboard, 5mm skim coat and 25mm of mineral wool between the studs
- one layer of 12.5mm panel board and 75mm of mineral wool between the studs.



Other forms of studwork construction may be acceptable where the sound reduction is achieved and independent evidence of performance is available.

Where mineral wool quilt is used for acoustic insulation in partitions, it should be of a suitable thickness and density. Where two layers of plasterboard are used, joints should be staggered and properly filled.

### Blockwork partitions

Masonry partitions provide adequate sound insulation without additional treatment where:

- blocks have a minimum density of 600kg/m<sup>3</sup> and are finished on both sides with 13mm of plaster, and
- blocks are tied at every course to adjoining walls, with joints fully filled.

### Proprietary partitions

Independent test evidence of the system's performance is required in accordance with Technical Requirement R3.

## Partitions: internal non load-bearing <sup>6.3.8</sup>

### Non load-bearing partitions shall have adequate strength and support.

The following constructions are acceptable:

- Masonry partitions.
- Timber partitions using 63mm x 38mm studs, sills and headplates with compatible spacing and plasterboard thickness.
- Steel partitions in accordance with Chapter 6.10 'Light steel frame walls and floors'.
- Proprietary partitions in accordance with Technical Requirement R3.

Walls and partitions should:

- be appropriately supported
- not be supported by a floating floor which incorporates a compressible layer, unless the material is specifically manufactured for that purpose.

Masonry partitions should be supported on:

- foundations
- other masonry partitions or walls
- concrete floors
- steel or concrete beams, which may require padstones.

Masonry partitions should not be supported by timber joists or beams.

Where stud partitions or proprietary plasterboard partitions are supported by a timber floor, extra noggings or joists should be specified unless it can be shown that the deck can transfer the load without undue movement.

## Construction of timber partitions <sup>6.3.9</sup>

*Also see: Chapter 9.2*

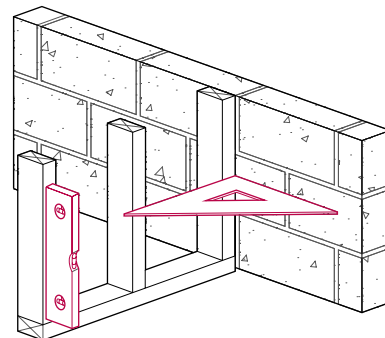
### Construction of timber stud internal walls shall ensure adequate stability, including:

- setting out and workmanship
- size of timber members
- fixing.

#### Setting out and workmanship

Partitions should be:

- correctly positioned, square and plumb
- have studwork spaced at centres to suit the plasterboard thickness
- have extra studs at openings, as required.



#### Size of timber members

Timber partitions should be constructed in accordance with the design information. Unless designed otherwise, the minimum specification for all partitions should be in accordance with Table 3.



**Table 3:** Timber sizes for partition walls

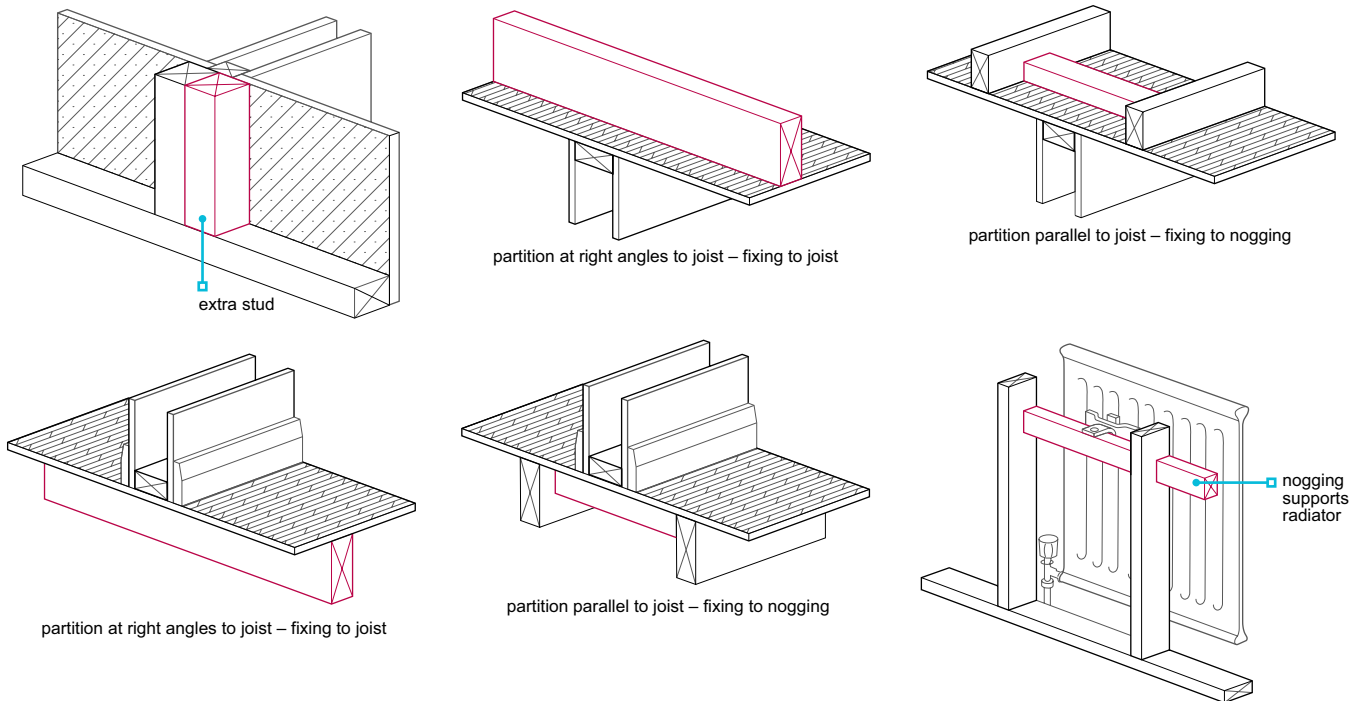
Component	Size
Sill and head plates	63mm x 38mm
Studs	63mm x 38mm at maximum 600mm centres
Blocking/nogging for support of plasterboard	43mm x 38mm
Blocking/nogging for other purposes	63mm x 38mm

Framing joints should be secured with two nails per joint.

**Fixing**

Partitions should:

- be firmly fixed to each other and to abutting walls; noggings or extra studs should be used where necessary
- be fixed to the structure where possible
- be fixed to noggings when parallel to structural elements
- not be over-wedged at floor level
- not be wedged against ceiling joists or roof trusses.



Noggings should be provided to support fittings, such as radiators, wall mounted boilers, sanitary fittings and kitchen units.

**Plasterboard** <sup>6.3.10</sup>

*Also see: Chapter 9.2*

**Plasterboard shall be of a suitable thickness for its intended use.**

Dry lining should comply with BS 8212. Plasterboard should be to BS 1230, and be:

- 9.5mm for stud spacing up to 450mm
- 12.5mm for stud spacing up to 600mm.

For sound-resisting walls (e.g. separating walls and walls to WCs), the correct thickness, number of layers and sealing should be specified in the design information.

Tapered edge boards should be used where the plasterboard is to be jointed before decoration.

### Construction of proprietary systems <sup>6.3.11</sup>

**Proprietary partition systems shall be suitable for their intended purpose and erected in accordance with the manufacturer's recommendations.**

Proprietary partitions should be assessed in accordance with Technical Requirement R3, and:

- constructed and specified according to the manufacturer's recommendations, including construction sequence
- correctly positioned, square and plumb.

Timber or other additional fixings should be provided for radiators, electrical outlets, switches etc.

### Damp-proof courses <sup>6.3.12</sup>

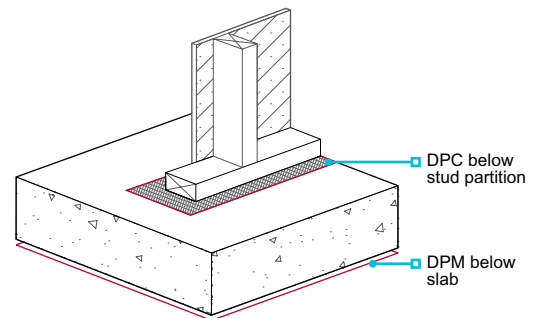
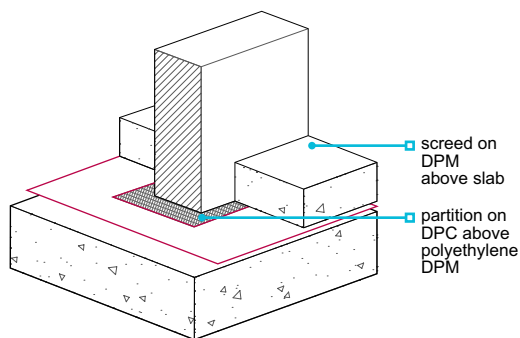
*Also see: Chapter 5.4*

**DPCs shall be installed where required to prevent moisture entering the building.**

Load-bearing partition walls built on foundations should have a DPC. Where partitions which could be affected by residual damp are placed on concrete floors, a DPC should be provided directly below, even where there is a DPM beneath the slab.

DPCs should be:

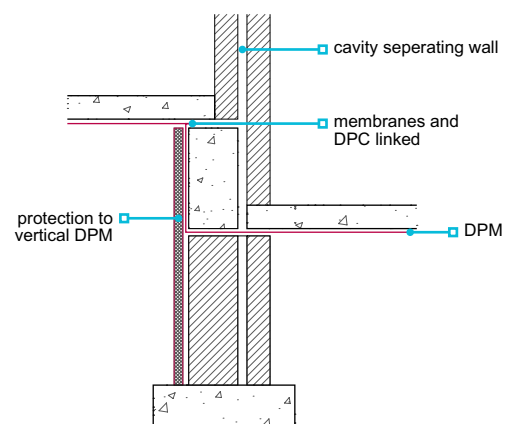
- at least the width of the wall or partition
- linked with any adjoining DPM
- continuous or lapped by a minimum of 100mm.



Where steps are necessary in the ground floor slab, a DPC should be:

- incorporated as a continuous link between the upper and lower DPCs
- protected from damage during construction.

Where steps are greater than 150mm, waterproofing should be provided in accordance with Chapter 5.4 'Waterproofing of basements and other below ground structures'.



Materials acceptable for DPCs include:

Bitumen	BS 6398
Polyethylene	BS 6515
Proprietary materials	Technical Requirement R3

### Components <sup>6.3.13</sup>

**Walls ties and related items shall be of the appropriate type and strength and shall have adequate durability.**

Joist hangers, restraint straps, bond ties, etc. should be protected against corrosion. Ferrous metals with the following levels of protection are acceptable:

- Post-galvanizing to BS 729, or
- Pre-galvanizing to BS 2989.

# Timber and concrete upper floors

## CHAPTER 6.4

This chapter gives guidance on meeting the Technical Requirements for timber and concrete upper floors.

6.4.1	Compliance	01
6.4.2	Provision of information	01
6.4.3	Upper floor design	01
6.4.4	Fire spread	02
6.4.5	Sound insulation	02
6.4.6	In-situ concrete floors and concreting	03
6.4.7	Precast concrete	03
6.4.8	Timber joist spans	04
6.4.9	Timber joists	06
6.4.10	Construction of timber floors	06
6.4.11	Joists supported by intermediate walls	08
6.4.12	Joists connected to steel	08
6.4.13	Joists into hangers	09
6.4.14	Timber joist and restraint straps	10
6.4.15	Strutting	12
6.4.16	Joists and openings	12
6.4.17	Multiple joists	13
6.4.18	Notching and drilling	13
6.4.19	Floor decking	14
6.4.20	Floating floors or floors between homes	16



Raising Standards. Protecting Homeowners

### Compliance <sup>6.4.1</sup>

*Also see: Chapter 2.1*

**Timber and concrete upper floors shall comply with the Technical Requirements.**

Timber and concrete upper floors that comply with the guidance in this chapter will generally be acceptable.

### Provision of information <sup>6.4.2</sup>

**Designs and specifications shall be produced in a clearly understandable format, include all relevant information and be distributed to appropriate personnel.**

Design and specification information should be issued to site supervisors, relevant specialist subcontractors and suppliers, and include the following information:

- Direction of floor span, and size and spacing of joists or concrete components.
- Size of trimmers and trimming joists.
- Position of strutting.
- Detailing of openings in the floor.
- Supporting walls below.
- Walls and partitions above.
- Positions of restraint straps.
- Positions of large service penetrations, e.g. chimneys, SVPs.
- Position of insulation.
- Details of all junctions.
- Manufacturers' recommendations for assembly and fixing of proprietary components.

### Upper floor design <sup>6.4.3</sup>

*Also see: Chapter 9.5*

**Upper floors shall support and transmit loads safely to the supporting structure without undue deflection.**

**Issues to be taken into account include:**

- a) loads and support to partitions
- b) steelwork.

#### Loads and support to partitions

Structural design of timber and concrete upper floors should be in accordance with BS EN 1991-1-1.

The design of upper floors should account for dead loads, including:

- floor structure, decking and finishes
- ceilings and applied finishes
- walls and partitions supported by the floor
- permanent fixtures such as boilers, watertanks etc.

Imposed loads should be calculated in accordance with the relevant British Standards, including BS EN 1991-1-1 which recommends:

- 1.5kN/m<sup>2</sup> for self-contained homes
- values for communal areas serving flats or maisonettes.

Bearers or additional joists should be used to support heavy loads.

Joists built into separating walls may provide lateral support, and should be detailed to ensure that sound insulation and fire resistance requirements are met.

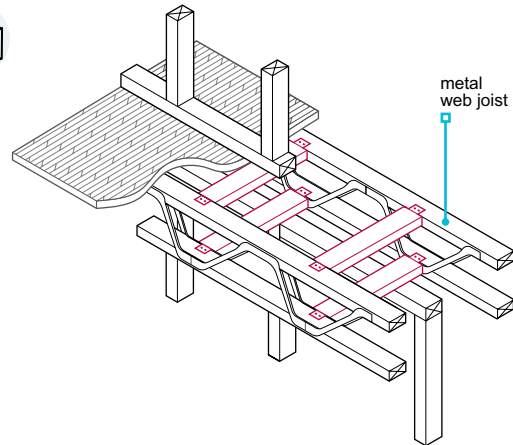
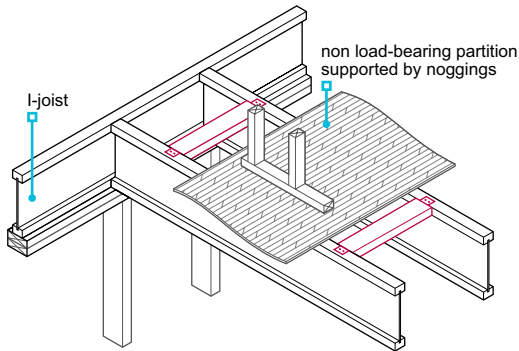
#### Masonry partitions

Where first floor masonry partitions cannot be built directly in line with ground floor masonry walls, steel or reinforced concrete support should be specified. Masonry should not be supported on joists.

#### Lightweight partitions

Where multiple solid timber joists support lightweight non load-bearing partitions which are parallel to the joists, they should be suitably fixed together. Where I-joists and metal web joists are used, they should:

- be positioned centrally below a non load-bearing partition and, where necessary, additional joists should be doubled or tripled in accordance with the manufacturer's recommendations
- support the weight of the non load-bearing partition by noggings or bearers fixed to the joists on either side. Unless designed otherwise, noggings should be a minimum 38mm x 90mm minimum at 600mm centres and fixed with metal clips. The sole plate of the non load-bearing partition should be fixed to the noggings, or
- be in accordance with the manufacturer's recommendations.



### Steelwork

Steelwork should be:

- designed by an engineer in accordance with Technical Requirement R5 and comply with Chapter 6.4 'Steelwork'
- sized to allow an adequate joist bearing.

Structural continuity of the floor should be provided by the use of continuous decking fixed to joists on both sides of a transverse steel joist.

Steel beams should be protected by a suitably durable paint coating as detailed in Chapter 6.5 'Steelwork'.

### Fire spread <sup>6.4.4</sup>

**Adequate fire resistance and fire stopping shall be provided by floors between homes and at penetrations. Upper floors shall be constructed to ensure structural timber is located away from heat sources.**

Floors and ceilings should:

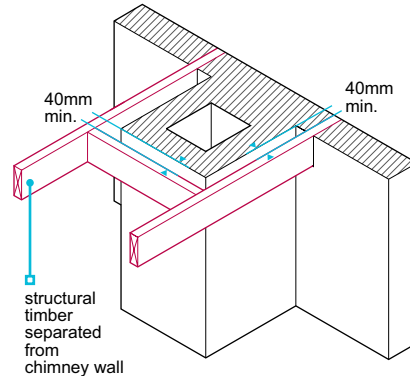
- comply with the relevant building regulations and Technical Requirement R3
- be in accordance with the design
- have adequate fire stopping
- should be able to resist the passage of smoke when the fire stopping has been installed.

Ceilings should not be perforated, e.g. for downlighters, unless it can be shown that the floor construction achieves the required fire resistance. Where downlighters are incorporated in a ceiling, they should be installed in accordance with the manufacturer's recommendations.

### Timber

To counteract fire spread:

- combustible material should be kept away from heat sources
- structural timber should be separated from sources of heat in accordance with Chapter 6.8 'Fireplaces, chimneys and flues'.



### Sound insulation <sup>6.4.5</sup>

**Upper floors shall be constructed to ensure that sound transmission is adequately limited.**

Timber upper floors should comply with building regulations and Chapter 9.3 'Floor finishes'.

### In-situ concrete floors and concreting <sup>6.4.6</sup>

**In-situ concrete upper floors shall be adequately reinforced and of a mix which is suitable for the location and intended use, and appropriately constructed.**

Concrete floors should:

- comply with BS EN 1992-1-1 and Chapter 3.1 'Concrete and its reinforcement'
- comply with the design
- be reasonably level and smooth, especially at doorways and junctions
- be in accordance with Technical Requirement R3 where proprietary elements are used.

### Precast concrete <sup>6.4.7</sup>

**Precast concrete upper floors shall be erected in accordance with the design.**

Precast concrete flooring systems should be in accordance with BS EN 1992-1-1 or Technical Requirement R3.

For precast concrete systems:

- details of manufacturer's assembly instructions and any independent certification should be available on site and followed
- beams, planks or infill blocks that are damaged should not be used
- adequate support should be provided until design strength is reached
- joints should be grouted in accordance with the manufacturer's recommendations.

Bearings should be:

- solid and level
- 90mm minimum on masonry (open frogs in brickwork should be filled)

The setting out of beam and block floors should:

- ensure correct spacing between beams, using infill blocks as spacers
- be in accordance with the design

Infill blocks should:

- be omitted or cut where necessary to allow for services

Where floors rely on structural topping or in-situ make-up sections, propping may be needed until the in-situ concrete has reached design strength.

#### Trimmed openings

Where voids in precast concrete floors are to be trimmed:

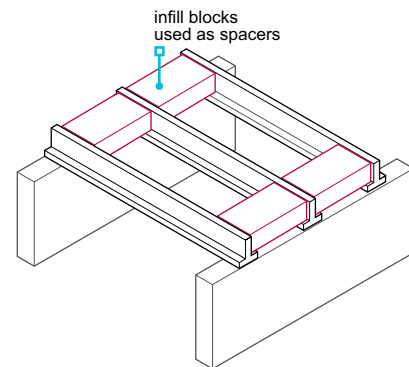
- specifications and drawings should be followed
- steel trimmer shoes may be used.

Double beams, common around trimmed openings, should be adequately supported until all voids have been solidly concreted and the concrete has reached its design strength.

#### Restraint straps and ties

Straps:

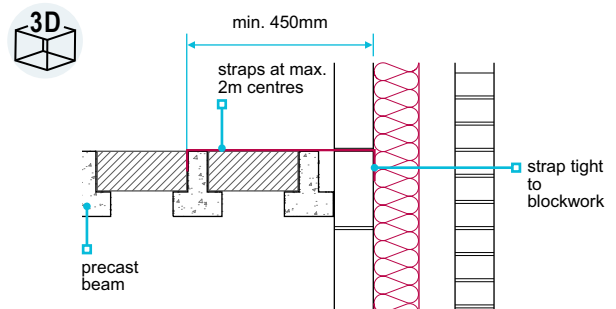
- should be shown in the design
- are generally required where beams run parallel with the wall



- 75mm minimum on steelwork.

- allow for additional beams where required to support concentrated loads such as partitions.

- be cut carefully and neatly without damage (not using a hammer and bolster).



**Timber joist spans** <sup>6.4.8</sup>

**Timber floor joists shall be adequate for the spans and loads, and be correctly installed.**

Solid timber joist sizes are provided in the BS 8103-3 span tables. Where the tables do not apply, or where there are concentrated loads, floor joists should be designed by an engineer in accordance with Technical Requirement R5.

**Span tables for solid timber joists**

Tables 1 and 2 in this chapter are derived from the TRADA Technology Ltd. 'Eurocode 5 span Tables for solid timber members in floors, ceilings and roofs for dwellings (3rd edition)'. The section sizes are based on regularised ALS or CLS timber.

For timber floors between homes:

- to meet acoustic performance, the dead load of the construction is likely to be 0.6-0.7kN/m<sup>2</sup>
- use the three right-hand columns from Tables 1 and 2.

For upper floors with 22mm thick chipboard decking and a 12.5mm plasterboard ceiling:

- a dead load of between 0.25kN/m<sup>2</sup> and 0.5kN/m<sup>2</sup> may be assumed
- use the centre three columns from Tables 1 and 2.

Where lightweight non load-bearing partitions weigh up to 1.0kN (101.9kg) per metre run and are parallel to the joists, the following applies:

- Partitions may be directly supported by one or two additional joists.
- Partitions should be fixed through the floor decking into the joist(s) beneath.
- Where similar lightweight partitions run at right-angles to the joists, the maximum spans in Tables 1 and 2 should be reduced by 10%.
- For all other additional loads, joist sizes should be designed by an engineer in accordance with Technical Requirement R5.

**Table 1:** Permissible clear spans for domestic floor joists.  
Strength class C16

Imposed load not exceeding 1.5 kN/m<sup>2</sup>.  
Service class 1 or 2.

Dead load g <sub>k</sub> (kN/m <sup>2</sup> ) excluding self-weight of joist										
Size of joist		g <sub>k</sub> not more than 0.25			g <sub>k</sub> not more than 0.50			g <sub>k</sub> not more than 1.25		
		Joist spacing (mm)								
		400	450	600	400	450	600	400	450	600
Breadth (mm)	Depth (mm)	Maximum clear span (m)								
38	97	1.76*	1.66*	1.43	1.64*	1.55*	1.35	1.43	1.35	0.71
38	120	2.36*	2.23*	1.94	2.18*	2.07*	1.80	1.86	1.77	<b>1.55</b>
38	145	2.85*	2.74*	2.48	2.68*	2.58*	2.32	2.33	2.22	<b>1.96</b>
38	170	3.33*	3.20*	<b>2.90</b>	3.14*	3.02*	<b>2.73</b>	2.74	<b>2.63</b>	<b>2.37</b>
38	195	3.81*	3.67*	<b>3.32</b>	3.59*	3.45*	<b>3.12</b>	<b>3.14</b>	<b>3.01</b>	<b>2.71</b>
38	220	<b>4.29*</b>	<b>4.13*</b>	<b>3.74</b>	<b>4.05*</b>	<b>3.89*</b>	<b>3.52</b>	<b>3.53</b>	<b>3.39</b>	<b>3.06</b>
44	97	1.89*	1.78*	1.54	1.76*	1.67*	1.45	1.53	1.45	1.27
44	120	2.48*	2.39*	2.08	2.33*	2.21*	1.94	1.98	1.88	1.66
44	145	2.99*	2.88*	2.61	2.82*	2.71*	2.45	2.46	2.36	<b>2.09</b>
44	170	3.50*	3.37*	3.05	3.30*	3.17*	2.87	2.88	2.77	<b>2.50</b>
44	195	4.00*	3.85*	<b>3.49</b>	3.78*	3.63*	<b>3.29</b>	<b>3.30</b>	<b>3.17</b>	<b>2.86</b>
44	220	4.51*	<b>4.33*</b>	<b>3.94</b>	4.25*	<b>4.09*</b>	<b>3.71</b>	<b>3.72</b>	<b>3.57</b>	<b>3.23</b>
47	97	1.95*	1.84*	1.60	1.81*	1.72*	1.50	1.57	1.49	1.31
47	120	2.54*	2.44*	2.15	2.39*	2.27*	2.00	2.04	1.94	1.71
47	145	3.06*	2.94*	2.67	2.88*	2.77*	2.51	2.52	2.42	2.15
47	170	3.58*	3.44*	3.12	3.37*	3.24*	2.94	2.95	2.83	<b>2.56</b>
47	195	4.09*	3.94*	<b>3.57</b>	3.86*	3.71*	<b>3.36</b>	3.38	<b>3.24</b>	<b>2.93</b>
47	220	4.60*	4.43*	<b>4.02</b>	4.34*	<b>4.18*</b>	<b>3.79</b>	<b>3.80</b>	<b>3.65</b>	<b>3.30</b>
50	97	2.00*	1.89*	1.65	1.87*	1.77*	1.54	1.61	1.53	1.34
50	120	2.59*	2.49*	2.22	2.44*	2.34*	2.05	2.09	1.99	1.75
50	145	3.12*	3.00*	2.72	2.94*	2.83*	2.56	2.57	2.47	2.21
50	170	3.65*	3.51*	3.19	3.44*	3.31*	3.00	3.01	2.89	<b>2.61</b>
50	195	4.17*	4.02*	3.65	3.94*	3.79*	<b>3.44</b>	3.45	<b>3.31</b>	<b>3.00</b>
50	220	4.70*	4.52*	<b>4.11</b>	4.43*	4.26*	<b>3.87</b>	<b>3.88</b>	<b>3.73</b>	<b>3.38</b>
63	97	2.23*	2.11*	1.84	2.07*	1.97*	1.72	1.78	1.70	1.50
63	120	2.80*	2.69*	2.44	2.64*	2.54*	2.28	2.30	2.19	1.94
63	145	3.37*	3.24*	2.95	3.18*	3.06*	2.78	2.79	2.68	2.42
63	170	3.94*	3.79*	3.45	3.72*	3.58*	3.25	3.26	3.13	2.84
63	195	4.50*	4.33*	3.94	4.25*	4.09*	3.72	3.73	3.58	<b>3.25</b>
63	220	5.06*	4.87*	4.44	4.78*	4.60*	<b>4.18</b>	4.20	4.04	<b>3.66</b>
75	120	2.96*	2.85*	2.59	2.79*	2.69*	2.44	2.45	2.35	2.09
75	145	3.56*	3.43*	3.12	3.37*	3.24*	2.94	2.95	2.84	2.57
75	170	4.16*	4.01*	3.65	3.93*	3.79*	3.44	3.45	3.32	3.01
75	195	4.75*	4.58*	4.17	4.49*	4.33*	3.94	3.95	3.80	3.45
75	220	5.34*	5.15*	4.70	5.05*	4.87*	4.43	4.45	4.28	<b>3.88</b>
ALS/CLS										
38	140	2.75*	2.64*	2.39	2.59*	2.49*	2.21	2.24	2.13	<b>1.88</b>
38	184	3.60*	3.46*	<b>3.14</b>	3.39*	3.26*	<b>2.95</b>	<b>2.96</b>	<b>2.84</b>	<b>2.56</b>
38	235	<b>4.58*</b>	<b>4.40*</b>	<b>3.99</b>	<b>4.32*</b>	<b>4.15*</b>	<b>3.76</b>	<b>3.77</b>	<b>3.62</b>	<b>3.27</b>
89	184	4.74*	4.57*	4.17	4.48*	4.32*	3.94	3.95	3.80	3.45
89	235	5.99*	5.78*	5.29	5.68*	5.48*	5.00	5.01	4.83	<b>4.39</b>

\* Two additional joists required

Bold text = normal bearing of 40mm to be doubled

**Table 2:** Permissible clear spans for domestic floor joists.  
Strength class C24

Imposed load not exceeding q<sub>k</sub> = 1.5 kN/m<sup>2</sup> or q<sub>k</sub> = 0.90 kN.  
Service class 1 or 2.

Dead load g <sub>k</sub> (kN/m <sup>2</sup> ) excluding self-weight of joist										
Size of joist		g <sub>k</sub> not more than 0.25			g <sub>k</sub> not more than 0.50			g <sub>k</sub> not more than 1.25		
		Joist spacing (mm)								
		400	450	600	400	450	600	400	450	600
Breadth (mm)	Depth (mm)	Maximum clear span (m)								
38	97	2.05*	1.94*	1.68	1.91*	1.80*	1.57	1.64	1.56	1.37
38	120	2.63*	2.53*	2.26	2.48*	2.38*	2.09	2.13	2.02	1.78
38	145	3.17*	3.05*	2.77	2.99*	2.87*	2.60	2.61	2.51	<b>2.25</b>
38	170	3.71*	3.57*	<b>3.24</b>	3.50*	3.36*	<b>3.05</b>	3.06	<b>2.94</b>	<b>2.65</b>
38	195	4.25*	4.08*	<b>3.71</b>	4.00*	<b>3.85*</b>	<b>3.49</b>	<b>3.50</b>	<b>3.36</b>	<b>3.04</b>
38	220	<b>4.78*</b>	<b>4.60*</b>	<b>4.17</b>	<b>4.51*</b>	<b>4.33*</b>	<b>3.93</b>	<b>3.95</b>	<b>3.79</b>	<b>3.42</b>
44	97	2.19*	2.07*	1.81	2.04*	1.93*	1.69	1.75	1.66	1.46
44	120	2.77*	2.66*	2.41	2.61*	2.50*	2.24	2.26	2.15	1.90
44	145	3.33*	3.20*	2.91	3.14*	3.02*	2.74	2.75	2.64	2.38
44	170	3.90*	3.75*	3.40	3.67*	3.53*	3.20	3.22	3.09	<b>2.79</b>
44	195	4.46*	4.29*	<b>3.90</b>	4.21*	4.04*	<b>3.67</b>	<b>3.68</b>	<b>3.54</b>	<b>3.20</b>
44	220	5.01*	4.82*	<b>4.39</b>	4.73*	<b>4.55*</b>	<b>4.13</b>	<b>4.15</b>	<b>3.98</b>	<b>3.61</b>
47	97	2.26*	2.14*	1.87	2.10*	1.99*	1.74	1.80	1.71	1.51
47	120	2.83*	2.72*	2.47	2.67*	2.56*	2.31	2.32	2.21	1.96
47	145	3.40*	3.27*	2.97	3.21*	3.09*	2.80	2.81	2.70	2.44
47	170	3.98*	3.83*	3.48	3.76*	3.61*	3.28	3.29	3.16	<b>2.86</b>
47	195	4.55*	4.38*	<b>3.98</b>	4.30*	4.13*	<b>3.75</b>	3.77	<b>3.62</b>	<b>3.27</b>
47	220	5.12*	4.93*	<b>4.48</b>	4.83*	<b>4.65*</b>	<b>4.23</b>	<b>4.24</b>	<b>4.08</b>	<b>3.69</b>
50	97	2.32*	2.20*	1.92	2.15*	2.04*	1.79	1.85	1.76	1.55
50	120	2.88*	2.77*	2.52	2.72*	2.62*	2.37	2.38	2.27	2.01
50	145	3.48*	3.34*	3.04	3.28*	3.15*	2.86	2.87	2.76	2.50
50	170	4.06*	3.91*	3.55	3.83*	3.69*	3.35	3.36	3.23	<b>2.92</b>
50	195	4.64*	4.47*	4.07	4.38*	4.22*	<b>3.88</b>	3.85	<b>3.69</b>	<b>3.35</b>
50	220	5.22*	5.03*	<b>4.58</b>	4.93*	4.75*	<b>4.32</b>	<b>4.33</b>	<b>4.16</b>	<b>3.77</b>
63	97	2.52*	2.43*	2.14	2.38*	2.26*	1.99	2.03	1.94	1.72
63	120	3.11*	2.99*	2.72	2.94*	2.83*	2.57	2.57	2.47	2.22
63	145	3.74*	3.60*	3.28	3.54*	3.40*	3.09	3.10	2.98	2.70
63	170	4.37*	4.21*	3.84	4.13*	3.98*	3.62	3.63	3.49	3.17
63	195	5.00*	4.81*	4.39	4.72*	4.55*	4.14	4.15	4.00	<b>3.62</b>
63	220	5.61*	5.41*	4.94	5.31*	5.12*	<b>4.66</b>	4.68	4.50	<b>4.08</b>
75	120	3.29*	3.17*	2.88	3.11*	2.99*	2.72	2.73	2.62	2.38
75	145	3.96*	3.81*	3.48	3.74*	3.60*	3.28	3.29	3.16	2.87
75	170	4.62*	4.45*	4.06	4.37*	4.21*	3.83	3.85	3.70	3.36
75	195	5.27*	5.08*	4.64	4.99*	4.81*	4.38	4.40	4.23	3.85
75	220	5.92*	5.71*	5.22	5.61*	5.41*	4.93	4.95	4.76	<b>4.33</b>
ALS/CLS										
38	140	3.07*	2.95*	2.67	2.89*	2.77*	2.51	2.52	2.42	<b>2.15</b>
38	184	4.01*	3.86*	<b>3.50</b>	3.78*	3.63*	<b>3.29</b>	<b>3.31</b>	<b>3.17</b>	<b>2.87</b>
38	235	<b>5.10*</b>	<b>4.90*</b>	<b>4.46</b>	<b>4.81*</b>	<b>4.62*</b>	<b>4.20</b>	<b>4.21</b>	<b>4.04</b>	<b>3.65</b>
89	184	5.25*	5.07*	4.63	4.98*	4.80*	4.38	4.39	4.23	3.85
89	235	6.64*	6.41*	5.87	6.30*	6.08*	5.56	5.57	5.37	<b>4.89</b>

\* Two additional joists required

Bold text = normal bearing of 40mm to be doubled



**Timber joists** 6.4.9

Also see: Chapter 3.3

**Joists shall be of an appropriate size and quality, and be suitably durable.**

I-joists and metal web joists should not be used in situations where any part of the joist is exposed to external conditions, and be:

- in accordance with Technical Requirement R3
- used in accordance with the manufacturer's recommendations
- specified using the following deflection limits based on total dead and imposed loads for combined bending and shear: 0.003 x the span, with a maximum deflection of 14mm where strutting is provided, or 12mm where strutting is not provided
- protected from adverse weather conditions during transport and storage
- stored clear of the ground and stacked vertically
- not used where damaged.

Structural solid timber joists should be specified according to the strength classes in BS EN 338, e.g. C16 or C24 and marked with:

- the strength class, or evidence of species and grade made available so as to determine the strength class
- the identification of the company responsible for the grading (when graded to BS 4978 or BS EN 519).

When graded to BS 4978:

- the species should be included in accordance with BS EN 1912 or the class strength specified
- BS EN 338 can be used to determine strength class.

Regularised timber should be used for solid timber joists, and be:

- dry graded to BS 4978 or BS EN 519
- marked 'DRY' or 'KD'.

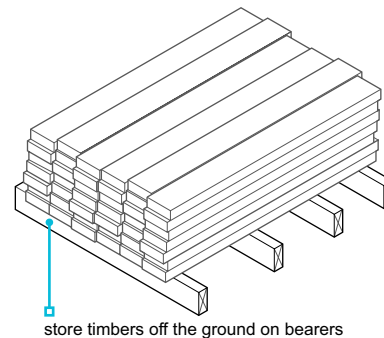
Materials should be checked on delivery for conformity with the design.

Timber should be treated with preservative where it is to be built in or embedded into solid external walls.

Joists should be stored on bearers or in racks and be protected.

Timber should not be used where:

- it is excessively bowed, twisted or cambered
- it has large edge knots or shakes
- it has a waney edge more than half the thickness
- it is damaged or has any sign of rot.



**Construction of timber floors** 6.4.10

Also see: Chapter 3.3

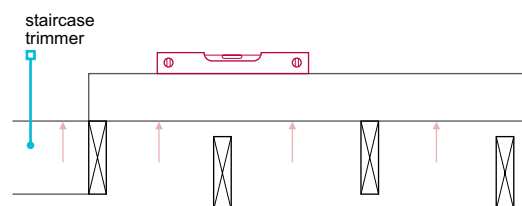
**Upper floors shall be constructed in a workmanlike manner and provide satisfactory performance. Issues to be taken into account include:**

- a) levelling
- b) joist spacing and clearance
- c) support.

**Levelling**

Bearings for joists should be level. The floor should be levelled:

- from the staircase trimmer and trimming joist
- in accordance with the manufacturer's recommendations
- using hard packing; loose or soft packing should not be used.



### Joist spacing and clearance

Joist spacing should:

- be in accordance with the design and not increased
- account for the decking material to be used
- be a maximum of 600mm
- have a clearance of 25-75mm between the first joist and the wall face to aid the installation of services and the fixing of floor decking.

### Support

The floor should have an adequate bearing on the supporting structure.

Timber joists should normally have a minimum bearing as shown in Table 3.

**Table 3:** Support of joists

Type of timber joist	Minimum bearing (mm)	
	End support	Intermediate support
Solid joist on masonry walls	90 (75)	90 (75)
Solid joist on timber wall plate	75	75
I-joist	90 (45)	90
Metal web joist	90 (75)	90

The figures in brackets should only be used when the joist is not providing restraint to the wall.

Joists may be:

- supported on joist hangers or on internal load-bearing walls
- built into the inner leaf of an external cavity wall, with care taken to ensure air-tightness.

Where joists are built into separating walls, fire-and sound-resisting performance, in accordance with building regulations, should be taken into account.

#### Solid timber joists

Where built into solid external walls, joists should be treated with preservative.

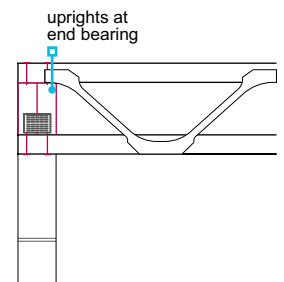
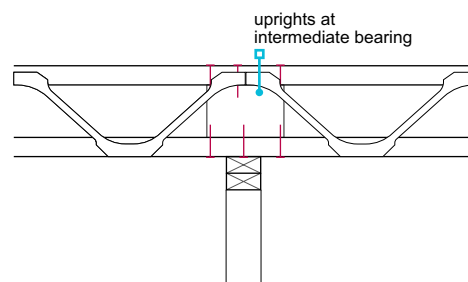
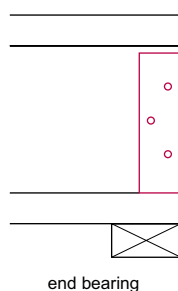
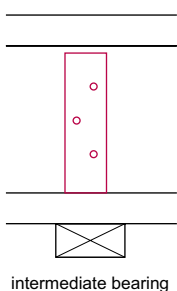
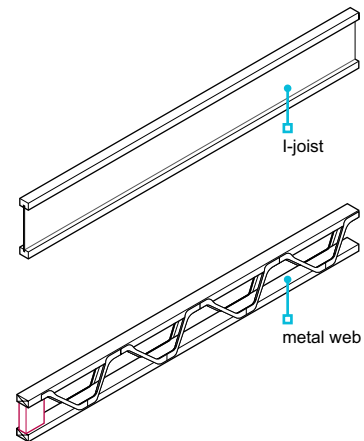
#### I-joists and metal web joists

I-joists and metal web joists should not be built into solid external walls.

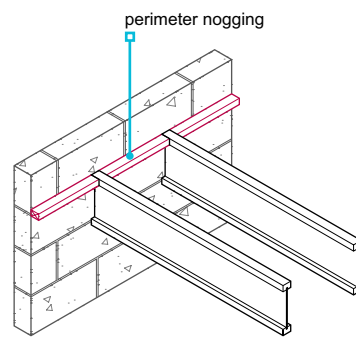
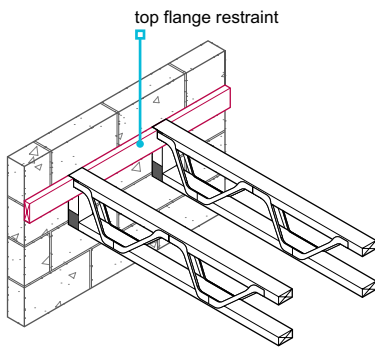
The support reaction, due to dead and imposed loads on the floor, should not exceed the recommended value specified by the manufacturer.

Where there are concentrated loads:

- web stiffeners should be used for I-joists
- uprights between the flanges, held in place by punched metal plate fasteners or bottom chord (flange) support, should be used for metal web joists
- the manufacturer's recommendations should be followed.



Where joists are supported on walls, noggings may be required at the top flange along the wall to support the floor decking, and at the bottom flange to support the plasterboard ceiling. Where joists are not built into brickwork or blockwork, blocking should be provided at the joist bearing. The blocking may be used for fixing plasterboard and floor decking.



**Joists supported by intermediate walls <sup>6.4.11</sup>**

**Joists shall be properly fixed at intermediate load-bearing walls.**

**Solid timber joists**

Solid timber joists bearing onto intermediate load-bearing walls should:

- be nailed together where they overlap
- not project more than 100mm.

**I-joists**

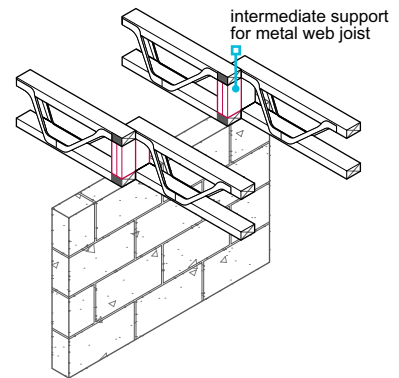
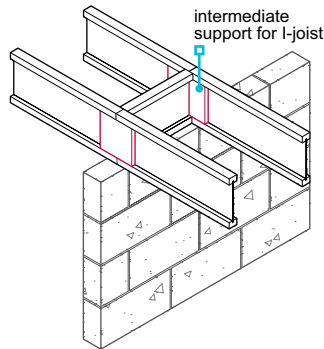
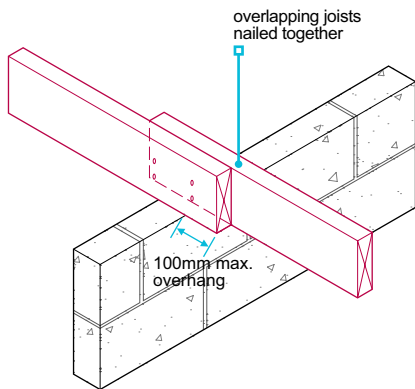
I-joists bearing onto intermediate load-bearing walls should have:

- blocking used to brace the butt joint
- short sections of joist used to provide lateral support.

**Metal web joists**

Metal web joists bearing onto intermediate load-bearing walls should:

- have a minimum 90mm bearing
- be overlapped.



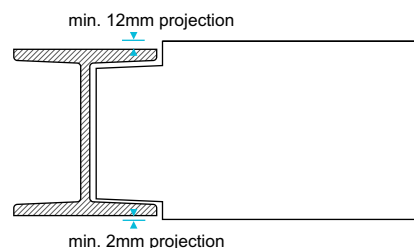
**Joists connected to steel <sup>6.4.12</sup>**

**Joists shall be suitably connected to steelwork.**

**Solid timber joists**

Where connected to steel beams, solid timber joists should:

- be deep enough to be notched
- have 12mm top and 2mm bottom projections to allow for timber shrinkage
- be provided with strutting to prevent rotation.



### I-joists

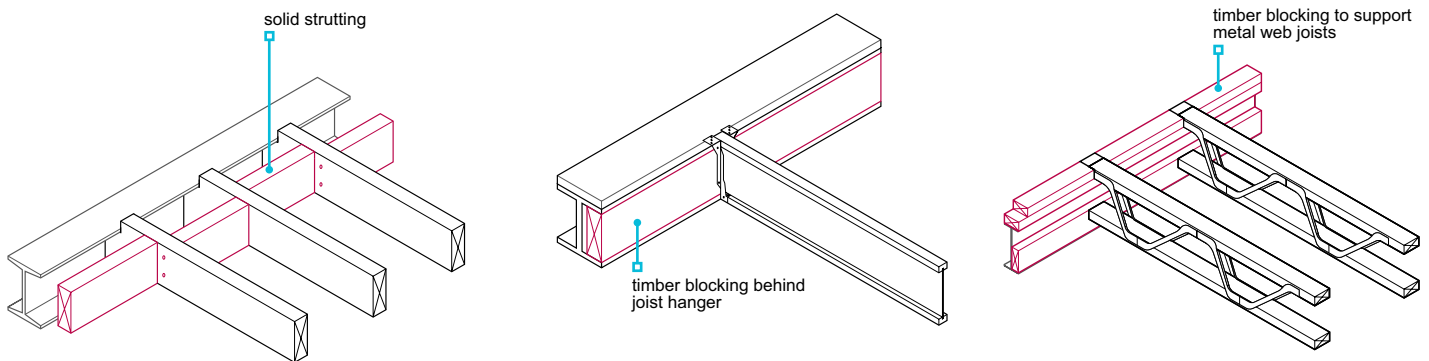
Where connected to steel beams, I-joists should not be notched at the flange, and should:

- bear directly into the steel beam where the bearing is more than 45mm. Strutting, (noggings 38mm x thickness of flange) should be provided at the top and bottom flanges, or
- have blocking fixed to the steel beam to enable the I-joists to be face fixed using joist hangers. Strutting is not required when hangers the full depth of the joist are used to face fix joists to the blocking.

### Metal web joists

Where connected to steel beams, metal web joists should not be notched at the flange, and should:

- bear directly into the bottom flange of the steel beam where the bearing is more than 75mm. There should be timber uprights between the flanges and 38mm x 97mm noggings between the uprights
- where the bearing is less than 75mm, the joist can be supported on the top flange with the bottom flange fixed to timber blocking supported inside the steel beam.



### Joists into hangers <sup>6.4.13</sup>

**Joist hangers shall provide a suitable bearing on the supporting structure and be of an adequate size, strength and durability.**

Masonry supporting joist hangers should be checked for level and height. The top flange loading on the joist hanger should not be greater than the strength of the supporting masonry. Where joist hangers are supported on lightweight blockwork, the suitability of the hanger should be checked. Joist hangers which meet BS EN 845 have a stamp indicating the minimum compressive strength of block for which they are suitable.

Hangers should:

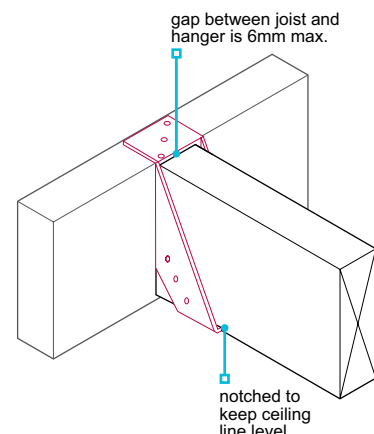
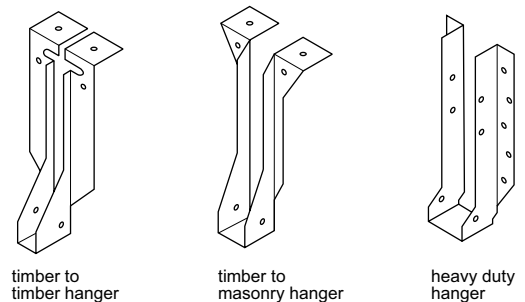
- be detailed in the design, including the type of support to be used for joists, trimmers and trimming joists
- have a 75mm minimum bearing on masonry
- comply with BS EN 845-1 or comply with Technical Requirement R3
- have performance equivalent to restraint straps at 2m centres where required to provide restraint
- be the correct size for the joist or trimmer
- be nailed through each circular hole in the vertical sides
- bear on level beds and be tight to the wall
- not be cut into the walling.

Joists should be accurately cut to length. Where joists are not built into brickwork or blockwork, blocking should be provided at the joist bearing. The blocking may be used for fixing plasterboard and floor decking.

### Solid joists

Where connected to hangers, solid timber joists should:

- have a minimum bearing of 75mm onto the hanger
- be notched into the hanger to keep the ceiling line level
- be the full depth of the hanger.



**I-joists**

Where connected to hangers, I-joists should not be notched at the flange, and should have:

- a minimum bearing of 45mm onto the hanger
- the tabs of the hanger bent and nailed to the bottom flange.

Hangers should be:

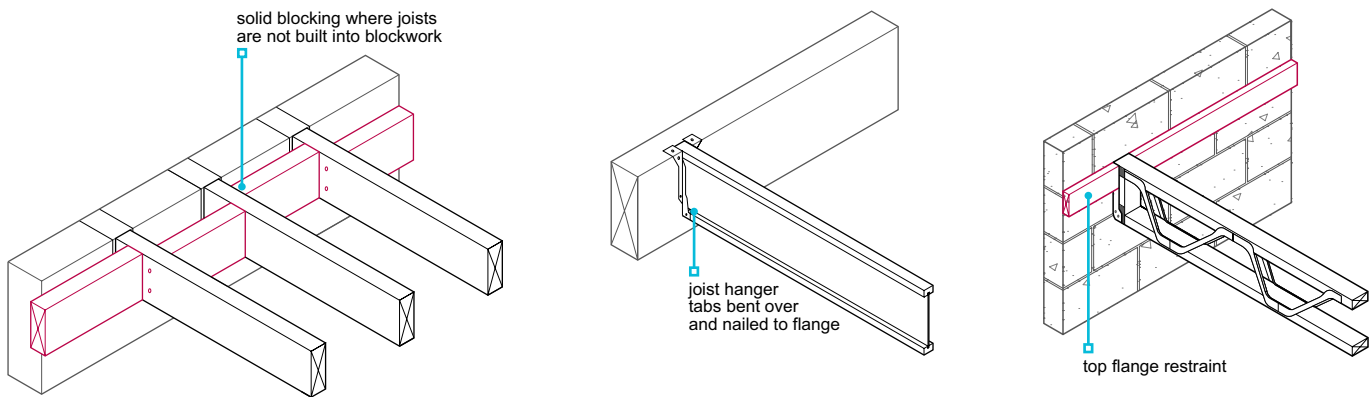
- the full depth of the joist and restrain the top flange, or
- at least 0.6 x the depth of the joist and have stiffeners (full depth) fixed to both sides of the web.

**Metal web joists**

Where connected to hangers, metal web joists should not be notched at the flange, and should have:

- a minimum bearing of 75mm onto the hanger
- timber uprights fixed between the flanges.

Hangers should be to the full depth of the joist and restrain the top flange, or another suitable means of restraining the top flange should be provided.



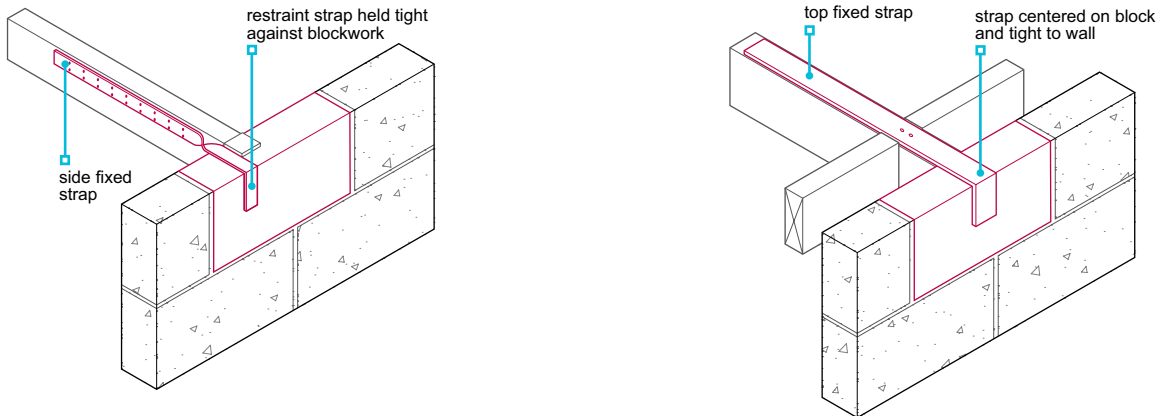
**Timber joist and restraint straps <sup>6.4.14</sup>**

*Also see: Chapter 6.1 and BS 8103-1*

**Upper floors shall provide adequate lateral restraint.**

Restraint straps and joist hangers suitable for taking tensile forces may be required to tie walls and upper floors together or when the external wall is stabilised by a connection to the floor. Straps should:

- be detailed in the design, including the size, position and fixings
- be galvanised steel with a 30mm x 5mm cross-section or be in accordance with Technical Requirement R3
- have adequate packing between the wall and the first joist
- bear on the centre of bricks or blocks and not on mortar joints
- be fixed on the side, top or bottom, as appropriate to the joist type.

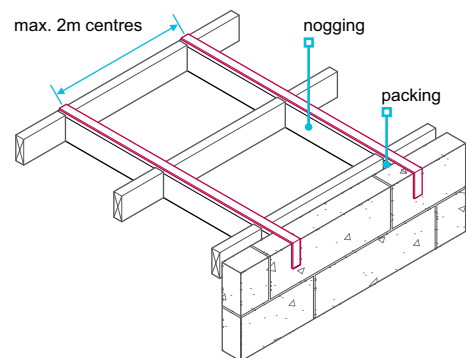
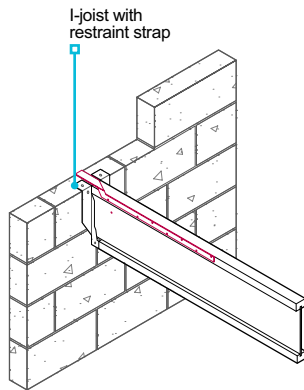


Restraint straps should be provided along the direction of the joists and spaced at a maximum of 2m centres. They are not generally required at the ends of joists in buildings up to, and including, two storeys where:

- restraint type joist hangers in accordance with Technical Requirement R3 are used, or
- joists are built into a wall and bear at least 90mm on the wall.

Where joists run parallel to the wall, straps should be fitted along the joists with a maximum spacing of 2m, and:

- be supported on noggings and extend over at least three joists
- be fixed with two screws or nails into each joist
- have noggings provided to receive two additional nails (for solid joists, two 4.76mm diameter x 50mm long wood screws (No.10) or 4mm diameter x 75mm round nails (8 SWG) can be used in each joist).



### Solid timber joists

Solid timber joists should, have noggings provided at:

- a minimum of 0.5 x the depth of the member when straps are located on top of the joist, or
- the full depth of the member where straps are located beneath the joist.

### I-joists

I-joists should not be notched and have:

- solid timber noggings no less than 0.5 x the depth of the member and a maximum of 150mm fixed between the webs and located beneath the top flange, when 30mm x 5mm galvanised straps are used, or
- noggings made from short lengths of I-joist, or solid timber the full depth of the I-joists, when proprietary straps are used.

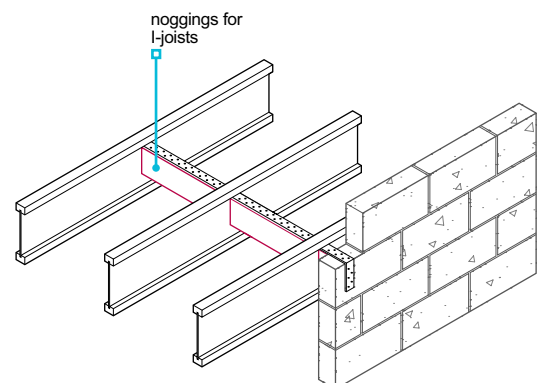
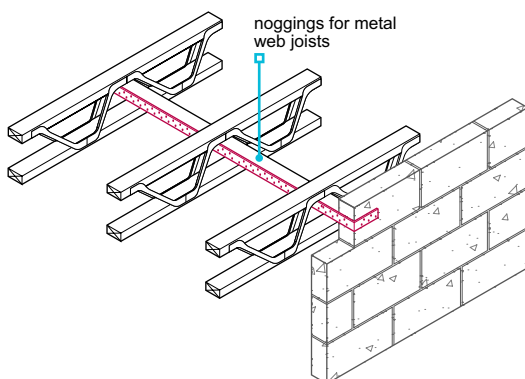
When nailing into laminated veneer lumber flanges:

- care should be taken to prevent splitting
- nails should be driven in at an angle (not horizontally) and should not protrude from the flanges.

### Metal web joists

Metal web joists should not be notched and should have:

- 35mm x 97mm solid timber noggings beneath the top flange of the metal web joists, and
- noggings nailed twice to each joist.



**Strutting** <sup>6.4.15</sup>

**Strutting shall be provided where required to distribute loads and ensure adequate rigidity of the floor structure.**

Strutting should:

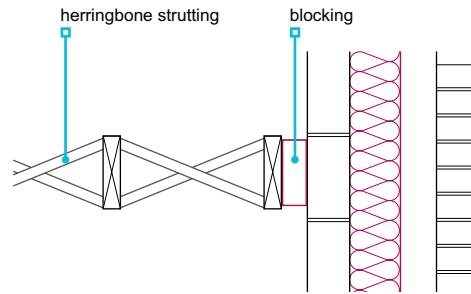
- not project beyond the top and bottom edges of joists
- be firmly blocked to the wall at the end of each run
- be provided before the deck is laid.

Proprietary metal strutting should comply with Technical Requirement R3.

**Solid timber joists**

Strutting to solid timber joists should be:

- provided in accordance Table 4



- be herringbone (38mm x 38mm timber) or solid (minimum 38mm thick and 0.75 x the depth of the joist).

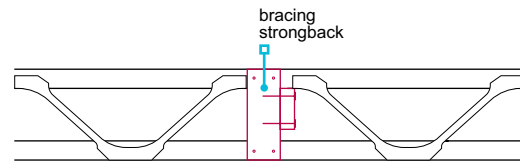
**Table 4:** Strutting for solid timber and I-joists

Joist span (m)	Rows of strutting
Under 2.5	None needed
2.5-4.5	1 (at centre of span)
Over 4.5	2 (at equal spacing)

**I-joists**

Strutting to I-joists should be:

- provided in accordance with the Table 4, where required.



**Metal web joists**

Strutting to metal web joists should be:

- provided in accordance with Table 5
- solid timber 'strongback' bracing.

**Table 5:** Strutting for metal web joists

Joist span (m)	Rows of strutting
4-8	1 (at centre of span)
over 8	2 (at equal spacing)

**Joists and openings** <sup>6.4.16</sup>

*Also see: Chapter 6.6*

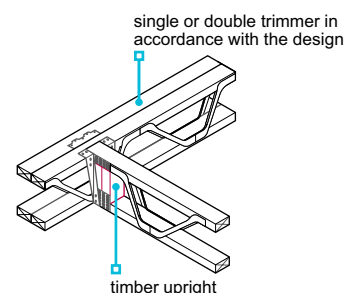
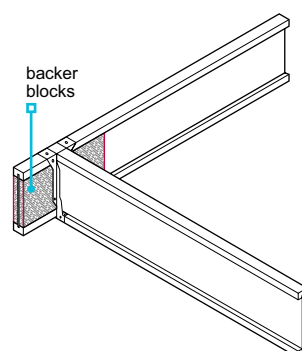
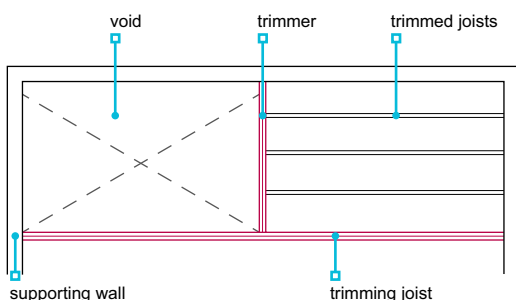
**Upper floors shall have adequately sized and properly supported trimmer joists around openings.**

Trimmed and trimming joists should be:

- detailed in the design
- designed in accordance with Technical Requirement R5.

Connections between joists should be made with suitable 'timber-to-timber' hangers, and:

- where face fixing I-joists to another I-joist, be provided with backer blocks on both sides of the web of the trimmer
- where metal web joists are used as a trimming joist to support another metal web joist, have timber uprights between the flanges of the trimmer.



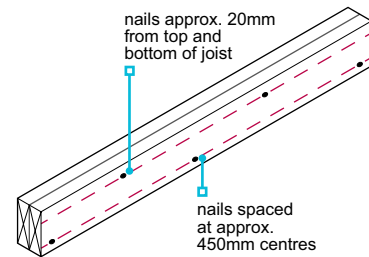
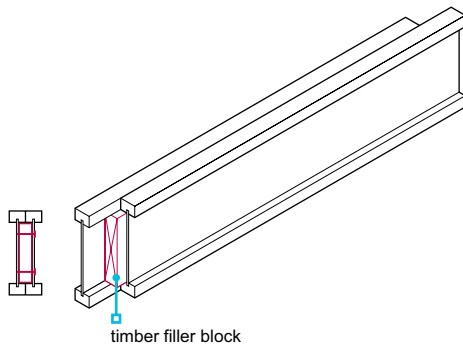
### Multiple joists <sup>6.4.17</sup>

#### Multiple joists shall be securely fixed together.

Joists can be doubled or tripled up to provide additional support, e.g. for lightweight partitions or to form trimmers. The design should specify how the joists are fixed together and be in accordance with manufacturer's recommendations.

When securing joists:

- fixings should be in accordance with the engineer's specification and should be checked before the ceiling is fixed, including the tightness of bolts
- toothed plate, split ring and shear plate connectors should be provided where required
- washers or single-faced connectors should be used with bolts
- ensure that timber is not damaged by over-tightening.



### Notching and drilling <sup>6.4.18</sup>

#### Notching and drilling shall be carried out within recognised limits.

##### Solid timber joists

Notching and drilling should be designed by an engineer where:

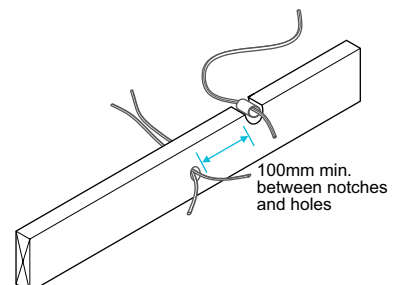
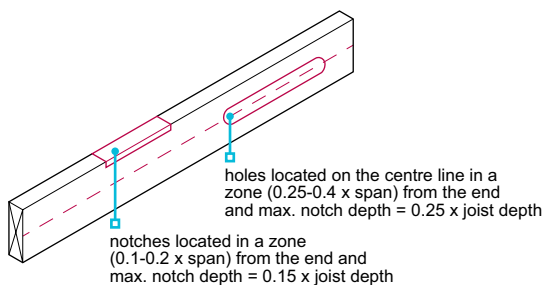
- the joist is deeper than 250mm
- it does not meet the guidelines in this chapter, or
- it is close to heavy loads, such as those from partitions, cisterns, cylinders and stair trimming.

Notching and drilling should:

- have a minimum horizontal separation of 100mm
- be in accordance with Table 6.

**Table 6:** Notching and drilling solid timber joists

	Location	Maximum size
Notching joists up to 250mm depth	Top edge 0.1-0.2 x span	0.15 x depth of joist
Drilling joists up to 250mm depth	Centre line 0.25-0.4 x span	0.25 x depth of joist





**I-joists**

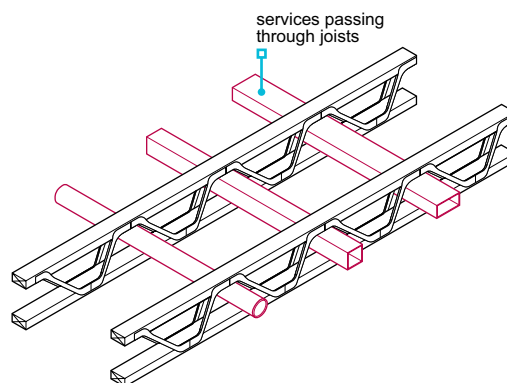
Preformed holes should be provided in the web and:

- holes or notches should not be cut without the approval of the manufacturer
- restraint straps can be slotted into webs immediately below the top flange.

**Metal web joists**

In metal web joists:

- service conduits should run in the gaps between the metal webs
- maximum duct sizes should be in accordance with the manufacturer's recommendations
- large service ducts may have to be inserted before fixing the joists, as it may not be possible after the joists have been fixed.



**Floor decking** <sup>6.4.19</sup>

**Floor decking shall be suitable for the intended use and be of adequate strength and moisture resistance.**

**Issues to be taken into account include:**

- a) type, thickness and fixing
- b) protection against damage.

**Type, thickness and fixing**

Where decking contributes to the sound insulation of a floor, the thicknesses listed in this chapter should be checked.

Floor decking should:

- be appropriate to the joist spacing
- be in accordance with Table 7 (which applies to normal domestic loads, i.e. an imposed load of 1.5kN/m<sup>2</sup>), or comply with Technical Requirement R3.

**Table 7:** Floor decking requirements

Floor decking	400mm joist centres	450mm joist centres	600mm joist centres	Standard
Softwood boarding	16	16	19	BS EN 13353
Moisture resistant chipboard	18	18	22	BS EN 312 – type P5
Plywood	15	15	18/19	BS EN 636
Oriented strand board	15	15	18/19	BS EN 300 – type OSB3

When installing decking:

- fixings and support should be in accordance with the manufacturer's recommendations
- checks should be made, prior to fixing, to ensure that noggings, blocking and strutting are in the correct position and secure
- butt joints should be staggered and supported on noggings or joists
- adjacent boards should be square
- where nails are used, they should be 2.5 x the thickness of the decking material
- where gluing is required, boards should be glued to the joists and at joints, using a suitable polyvinyl acetate (PVAc) adhesive
- temporary wedges and packing should be removed once the floor decking is complete.

### Square edged boards and boards with loose tongues

When fixing boards with square edges or loose tongues, they should be supported on all sides by joists or noggings.

### Tongued and grooved boards

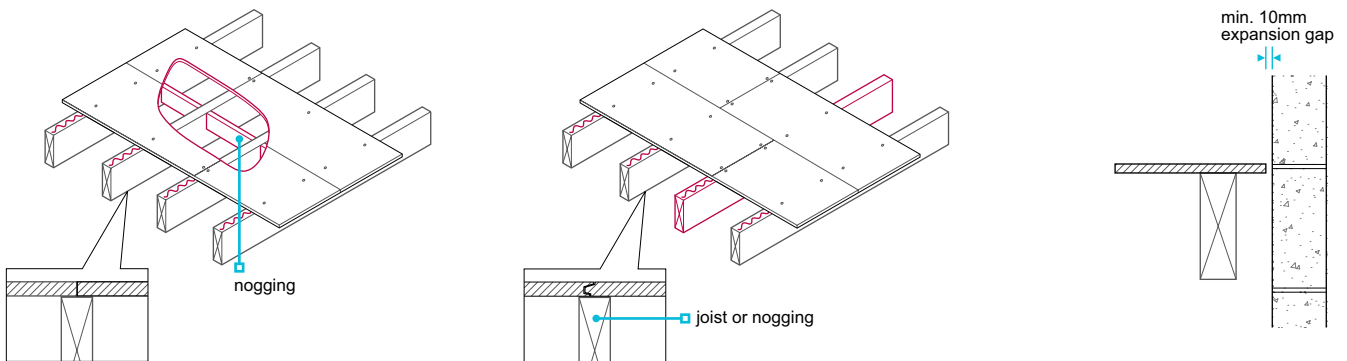
When fixing boards with tongued and grooved edges:

- boards should be laid with long edges at right angles to joists
- short edges should be supported on joists or noggings or cut back to form a butt joint over a joist
- boards should be glued to the joists and the sheets glued to each other with polyvinyl acetate (PVAc) adhesive (not softwood boarding)
- long edges at room perimeters should be fully supported on joists or noggings.

### Chipboard flooring

Chipboard flooring should be supported and fixed in accordance with manufacturers' recommendations using either:

- flat-headed ring shank nails, 2.5 x the thickness of the board and minimum 3mm diameter, or
- screws to BS 1210, minimum 2 x the thickness of the board and no less than size No. 8.



When fixing:

- fixings should have a maximum spacing of 300mm along continuously supported edges and intermediate supports
- where boards abut a rigid upstand, a minimum 10mm expansion gap should be provided; for large areas of boarded floor, a wider expansion gap may be required at upstands and intermediate expansion gaps of 2mm per linear metre of floor should be provided.

### Oriented strand board flooring

When fixing oriented strand board flooring:

- boards should be laid over supports in the direction indicated on the board, with the stronger axis at right angles to the supporting joists
- boards should be long enough to span two joists
- nails should be flat headed, annular grooved nails, 3mm in diameter
- where boards abut a rigid upstand, a minimum 10mm expansion gap should be provided; for large areas of boarded floor, a wider expansion gap may be required at upstands and intermediate expansion gaps of 2mm per linear metre of floor should be provided.

### Plywood flooring

When fixing plywood flooring:

- boards should be laid with the face grain at right angles to the supports
- end joints should occur over joists or noggings
- fixings should have a maximum spacing of 150mm around the perimeter and a maximum spacing of 300mm on intermediate supports
- an expansion gap of at least 1.5mm-2mm should be allowed between each panel.

Nails for fixing plywood should be in accordance with Table 8.

**Table 8:** Fixings for plywood floors

	Plain wire nails (mm)	Annular ring shank nails (mm)
Minimum diameter	3.35	3
Minimum length	65	50
Minimum penetration	40	32

### Proprietary flooring

Proprietary flooring should be:

- in accordance with Technical Requirement R3
- installed in accordance with certification requirements.

### Protection against damage

---

Floor decking should be stored:

- on a hard base
- indoors where possible.
- under cover

Where timber decking is to be installed before the home is watertight, the manufacturer should confirm suitability.

Floors should not be overloaded, especially with materials during construction, and be protected against damp, plaster splashes and other damage.

### Floating floors or floors between homes <sup>6.4.20</sup>

**Floating floors shall be separated from the main structure and surrounding walls by a resilient layer.**

The structural component of floors between homes may be concrete, steel, timber or a combination of these materials.

The floor finish should be isolated from walls and skirtings.

Where board materials are laid loose, joints in tongued and grooved boards should be glued.

Proprietary floating floor materials and systems should be fixed in accordance with:

- building regulations
- relevant certification requirements.
- manufacturer's recommendations

# Steelwork

## CHAPTER 6.5

This chapter gives guidance on meeting the Technical Requirements for steelwork:

- steelwork which supports masonry partitions and timber floors, including trimmed openings
- the protection of steelwork.

6.5.1	Compliance	01
6.5.2	Design guidance	01
6.5.3	Steel grade and coatings	03
6.5.4	Installation and support	05
6.5.5	Padstones	05
6.5.6	Connections	06
6.5.7	Examples	07



Raising Standards. Protecting Homeowners

### Compliance <sup>6.5.1</sup>

*Also see: Chapter 2.1*

#### Steelwork shall comply with the Technical Requirements.

Steelwork (including trimming to floor voids) for supporting masonry partitions or timber floors which comply with the guidance in this chapter will generally be acceptable.

The information provided in this chapter is in accordance with BS EN 1993-1-1 using grade S275 steel; however, more economical or smaller beams may be designed by an engineer.

Steelwork, including its support and any connections, should be:

- designed by an engineer in accordance with Technical Requirement R5, or
- detailed in accordance with this chapter.

### Design guidance <sup>6.5.2</sup>

*Also see: Chapters 6.1, 6.3 and 6.4*

#### Steelwork shall be designed to support and transmit loads to the supporting structure without undue movement or deflection. Issues to be taken into account include:

- a) support of masonry partitions
- b) support of timber floors, including trimmed openings.

#### Support of masonry partitions

Masonry partitions may be supported by steelwork selected in accordance with this chapter. Care should be taken to avoid masonry supported by steelwork being partially supported or out of true.

#### Conditions for Tables 1 and 2

Steel beams in accordance with Tables 1 and 2 of this chapter will generally be acceptable for the support of masonry partitions where the following conditions are met:

- The partition is of one of the types detailed in Table 1.
- The partition is built centrally on the steelwork beam and is less than 2.7m in height.
- The span of the steel beam is less than 4m.
- Steel beams only support the weight of the partition and self-weight.
- Brickwork or blockwork (workface size 440mm x 215mm) supporting the steel beam has a minimum strength of 2.8N/mm<sup>2</sup> and the beam supports do not occur over a door or window opening.
- Padstones are provided where required, in accordance with Table 6.

Where any of the conditions are not met, steelwork should be designed in accordance with Technical Requirement R5.

Method of applying tables:

- Ensure that all conditions apply.
- Identify the masonry partition construction and thickness.
- Use Table 1 to establish the load per metre run.
- Check the span of the beam(s).
- Use Table 2 to determine a suitable steel section size.
- Use Table 6 to determine if padstones are required.

An example is provided at the end of this chapter.

**Table 1:** Load of partition to be supported

Type of masonry for supported partition (not more than 2.7m high and plastered both sides)	Maximum masonry density (kg/m <sup>3</sup> )	Structural thickness (mm)		
		100	90	75
		Load (kN/m run)		
Dense masonry	2000	6.8	6.2	5.4
Medium masonry	1400	5.1	4.8	4.2
Lightweight masonry	800	3.5	3.3	2.9

**Table 2:** Size of steel beam supporting partition

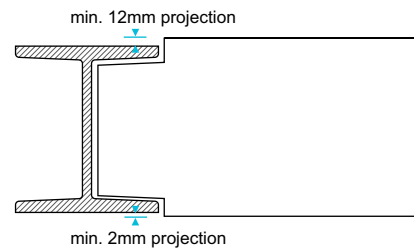
Partition load (from Table 1) (kN/m run)	Clear span of beam (m)	Smallest suitable universal beam size (mm x mm x kg/m)
Less than 3	Up to 4 Over 4	127 x 76 x 13 (2)
3 to 5	Up to 3 3 to 3.5 3.5 to 4 Over 4	127 x 76 x 13 152 x 89 x 16 178 x 102 x 19 (2)
5 to 7	Up to 2.5 2.5 to 3 3 to 4 Over 4	127 x 76 x 13 152 x 89 x 16 178 x 102 x 19 (2)

**Notes**

- For spans up to 4m, universal column 152mm x 152mm x 23kg/m (smallest size available) may be used.
- For spans over 4m, beams should be designed by an engineer in accordance with Technical Requirement R5.

**Support of timber floors, including trimmed openings**

Timber floors may be supported by steelwork selected in accordance with this chapter and should include full allowance for the shrinkage of timber joists.



**Conditions for Tables 3 and 7**

Steel beams in accordance with Tables 3 and 7 will be acceptable to NHBC for the support of floors, where the following conditions are met:

- The floor construction is of decking (softwood boarding, chipboard, oriented strand board or plywood) on timber joists and the ceiling is plasterboard with a plaster skim coat or a plastic finish (Artex or similar).
- Allowance has been made of 0.5kN/m<sup>2</sup> for self-weight (floor and ceiling load).
- The floor does not support masonry partitions.
- Any lightweight partition, such as plasterboard on timber studwork or proprietary product, is non load-bearing.
- Padstones are provided where required in accordance with Table 6.
- Clear span of beam does not exceed 4.4m.
- Connections between steelwork beams are in accordance with clause 6.5.6, or are designed by an engineer.
- The floor support is one of the methods shown in Figure 1.

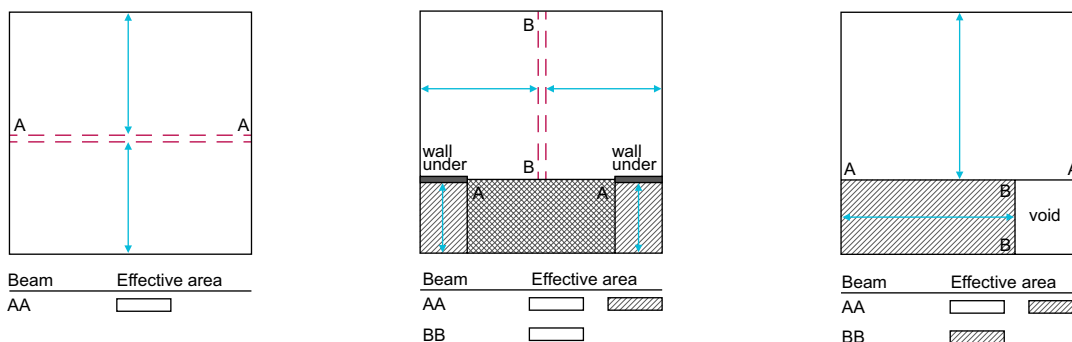
Where any of the conditions are not met, steelwork should be designed by an engineer in accordance with Technical Requirement R5.

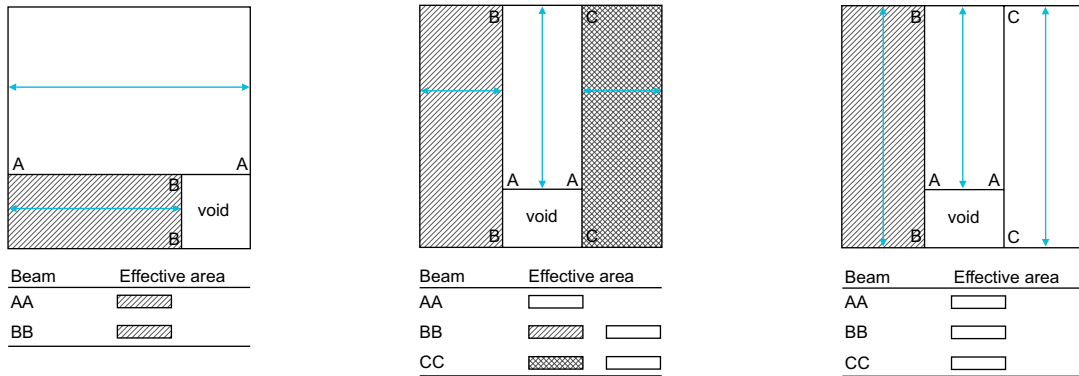
**Method of applying tables:**

- Use Figure 1 to determine the area supported by the beam(s).
- Check the span of the beam(s).
- Use Table 3 to determine a suitable steel section size.
- Use Table 7 to determine if padstones are required.
- Where steel beam-to-steel connections are required, refer to the connections in Clause 6.5.6.

Ensure that all conditions apply.

**Figure 1:** Effective areas supported by steel beams





Where any area shown as 'void' contains a staircase, add 2m<sup>2</sup> to the effective area supported by any beam which fully or partially supports that staircase.

**Table 3:** Size of steel beam supporting timber floor

Effective area supported (m <sup>2</sup> )	Effective trimmer span = clear span + 100mm (m)	Smallest suitable steel section size (mm x mm x kg/m)	
		Universal beam	Universal column
0 to 20	0 to 2.0	127 x 76 x 13	152 x 152 x 23
0 to 20 20 to 30	2 to 2.5	127 x 76 x 13 152 x 89 x 16	152 x 152 x 23 152 x 152 x 23
0 to 10 10 to 20 20 to 30	2.5 to 3	127 x 76 x 13 152 x 89 x 16 178 x 102 x 19	152 x 152 x 23 152 x 152 x 23 152 x 152 x 23
0 to 10 10 to 30 30 to 40	3 to 3.5	127 x 76 x 13 178 x 102 x 19 203 x 133 x 25	152 x 152 x 23 152 x 152 x 23 152 x 152 x 30
0 to 10 10 to 20 20 to 30 30 to 40 40 to 50	3.5 to 4	152 x 89 x 16 178 x 102 x 19 203 x 102 x 23 203 x 102 x 30 *	152 x 152 x 23 152 x 152 x 23 152 x 152 x 23 152 x 152 x 30 152 x 152 x 37
0 to 10 10 to 20 20 to 30 30 to 40 40 to 50	4 to 4.5	203 x 102 x 23 203 x 133 x 25 203 x 133 x 30 * *	152 x 152 x 23 152 x 152 x 23 152 x 152 x 30 152 x 152 x 37 203 x 203 x 46

\*Beams should be designed by an engineer in accordance with Technical Requirement R5.

### Steel grade and coatings <sup>6.5.3</sup>

**Steelwork shall be specified to provide sufficient strength, durability, and fire resistance.**

The design should detail the method of fixing or connecting structural steelwork. The guidance given in this chapter applies to steelwork which is to be bolted (using black bolts) or not connected.

Steelwork should be in accordance with the guidance in this chapter and:

- BS 4 Part 1 'Structural steel sections: Specification for hot-rolled sections', or
- BS 4848 'Specification for hot-rolled structural steel sections'.

To ensure adequate durability in the environment it will be exposed to steelwork should:

- have a protective coating system applied before being delivered to site
- comply with the level of fire resistance required by building regulations.

Where welding is to be carried out, the protective coating system specified by the designer should be used.

Further guidance on the protection of structural steel is given in BS EN ISO 12944 'Paints and varnishes. Corrosion protection of steel structures by protective paint systems' and BS EN ISO 14713 'Protection against corrosion of iron and steel in structures'.

Decorative finishes should be compatible with the protective coat specification. The designer should determine compatibility in accordance with the manufacturer's recommendations. Chapter 9.5 'Painting and decorating' contains further guidance for decorative paint finishes to steelwork.

**Table 4:** Environment categories for component groups in different locations and exposure conditions

Component group	Location	Description of exposure condition	Environment categories
External	Outside a home	Above splash zone	C4 or C5 <sup>(1)</sup>
		At ground level within splash zone (up to 150mm above ground)	C5 <sup>(2)</sup>
	Outside or basement	Below ground level	C5 <sup>(2)</sup>
Internal	Sub-floor void <sup>(3)</sup>	Unventilated	C3
		Ventilated	C2
Internal	Kitchen/bathroom, etc.	Moist humid conditions – protected against condensation	C2
	Kitchen/bathroom, etc.	Moist humid conditions – exposed to condensation	C2
	Rooms other than kitchen/bathroom, etc.	Warm dry	C2
	In roof void	Unheated dry	C2
Internal/external	Façade	Embedded or partially embedded in building envelope	C5 <sup>(4)</sup>

Notes

- 1 For construction located within 500m of coastal shoreline.
- 2 Alternatively, steelwork may be encased in concrete.
- 3 For steelwork not in contact with the ground.
- 4 For steelwork in contact with, or embedded in an external masonry wall, for at the contact / embedment length.

Alternatively, guidance on suitable atmospheric corrosivity categories (C1 – C5) and appropriate protective coatings for domestic construction may be based on the recommendations given on the website [www.steelconstruction.info](http://www.steelconstruction.info). A site specific assessment is required in order to determine an appropriate classification level for the steelwork. A suitable protective coating specification is to be determined by the designer in accordance with the coating manufacturer's recommendations.

**Table 5:** Protective coatings for hot rolled structural steelwork for atmospheric corrosivity category (recommended for housing applications only)

Atmospheric corrosivity and risk	Surface preparation <sup>(4)</sup>	Protective coating <sup>(1, 2, 3)</sup>			Site or factory applied	Making good of damaged areas of protective coating
		Material	Minimum coating thickness (d.f.t.) <sup>(5)</sup> / weight <sup>(6)</sup>	Number of coats		
C1 Very low	N/A	None required.	N/A	N/A	N/A	N/A
C2 Low	Thoroughly clean surface prior to abrasive blast cleaning to Sa 2½.	High build zinc phosphate epoxy primer <sup>(7)</sup>	80 µm <sup>(8)</sup>	1 or 2	Factory	Thoroughly wire brush damaged areas and build up coats using the same materials and to the same d.f.t.
C3 Medium	Thoroughly clean surface prior to abrasive blast cleaning to Sa 2½.	High build zinc phosphate epoxy <sup>(7)</sup> primer, followed by high build recoatable epoxy micaceous iron oxide (MIO)	80 µm <sup>(8)</sup>  120 µm  (200 µm in total)	1 or 2  1	Factory	Thoroughly wire brush damaged areas and build up coats using the same materials and to the same d.f.t.
C4 <sup>(9)</sup> High		Hot dip galvanize to BS EN ISO 1461	460 gms/m <sup>2</sup>	1	Factory	To be determined by the designer in accordance with the manufacturer's recommendations.
C5 <sup>(9)</sup> Very high		Hot dip galvanize to BS EN ISO 1461	710 gms/m <sup>2</sup>	1	Factory	To be determined by the designer in accordance with the manufacturer's recommendations.

Notes

- 1 Where steelwork is to be given a decorative finish, the protective coat is to be compatible with the decorative finish. Manufacturers' recommendations should be followed.
- 2 Where steelwork is to be protected by intumescent paint for fire purposes, manufacturers' recommendations should be followed.
- 3 All fixings and fittings to the structural steel elements are to be protected against corrosion in a manner that is both commensurate and compatible with the protective coatings.
- 4 Surface preparation to BS EN ISO 12944-4.
- 5 Coating thicknesses given represent nominal dry film thickness (d.f.t.).
- 6 Thicknesses and weights shown represent the coating to be applied to each face of a steel section.
- 7 Epoxy primers have a limited time for over-coating. Manufacturers' recommendations should be followed.
- 8 80 µm can be in one coat or as 20 µm pre-fabrication primer plus 60 µm post-fabrication primer.
- 9 Alternatively, use products manufactured from austenitic stainless steel in accordance with the recommendations of BS EN 1993-1-4:2006.



Where shop-applied protective coatings have been damaged, the coatings should be made good on site prior to being built into the works, as indicated in Table 5 'Making good of damaged areas'.

Where steelwork is to be welded, the protective coating system specified by the designer should be used.

Where steelwork is to be protected by intumescent paint for fire purposes, this should be in accordance with the manufacturer's recommendations.

### Installation and support <sup>6.5.4</sup>

**Steelwork shall be installed to achieve the required structural performance. Issues to be taken into account include:**

- a) section size and grade detailed in the design
- b) steelwork support.

#### Section size and grade detailed in the design

When materials are delivered to site, they should be checked to ensure conformity with:

- engineer's design, or
- steelwork sizes in this chapter.

#### Steelwork support

Beam supports should not occur above window or door openings. Bearings for steelwork supported on masonry should be:

- 100mm minimum
- clean, dry and level.

### Padstones <sup>6.5.5</sup>

**Steelwork shall be supported by padstones where required to distribute point loads safely to the supporting structure without undue movement or deflection.**

Where a steel beam is supported by masonry, a padstone may be required to spread the load over a larger area to prevent overstressing. Padstones should be in accordance with:

- the engineer's design, or
- the guidance given in this chapter.

Where the inner leaf of the cavity wall contributes to the overall thermal performance of the wall, padstones should:

- have similar thermal properties to the masonry used for the rest of the inner leaf, or
- not create a cold bridge.

**Table 6:** Size of padstones (for steel supporting partition walls)

Type of masonry for supported partition (not more than 2.7m high and plastered both sides)	Thickness of wall supporting beam (mm)						Minimum depth of padstone (mm)
	100	125	140	150	190	215	
Minimum length of padstone (mm)							
Dense masonry	215	190	185	180	165	155	150
Medium masonry	155	140	135	130	120	110	150
Lightweight masonry	95	85	80	75	70	70	150

#### Notes

- 1 Padstones are not necessary where the flange dimension of the beam exceeds the length of the padstone given in this table.
- 2 When steelwork is in line with the wall supporting it, i.e. when acting as a lintel over an opening:
  - the flange dimension of the beam should not be more than 50mm greater than the thickness of the supporting wall
  - the minimum length of padstone should be 200mm
  - the padstone depth should match the coursing of adjacent masonry
  - the web of the beam should be over the centre of the wall.
- 3 The minimum length of steel bearing onto padstone should be 100mm.

**Table 7:** Size of padstones (for steel supporting floors)

Effective area supported (as used in Table 3) (m <sup>2</sup> )	Minimum padstone size (mm)					
	Thickness of wall supporting steel beam (mm)					
	Up to 105		105 to 155		156 to 216	
	Length	Depth	Length	Depth	Length	Depth
Up to 10	95	150	80	150	70	150
10 to 20	185	150	160	150	140	150
20 to 30	275	150	240	150	210	150
30 to 40	365	215	320	150	280	150
40 to 50	455	300	400	215	345	215

Notes

- 1 Padstones are not necessary where the flange dimension of the beam exceeds the length of the padstone given in this table.
- 2 When steelwork is in line with the wall supporting it, i.e. when acting as a lintel over an opening:
  - the flange dimension of the beam should not be more than 50mm greater than the thickness of the supporting wall
  - the minimum length of padstone should be 200mm
  - the padstone depth should match the coursing of adjacent masonry, and
  - the web of the beam should be over the centre of the wall.

Padstones should be formed in one unit with a minimum compressive strength of 10 N/mm<sup>2</sup> from:

- in-situ concrete
- precast concrete
- concrete blocks
- clay bricks, or
- engineering bricks (when less than 215mm x 100mm).

**Connections** <sup>6.5.6</sup>

**Connections shall be chosen and installed to achieve the required structural performance.**

Steelwork connections should:

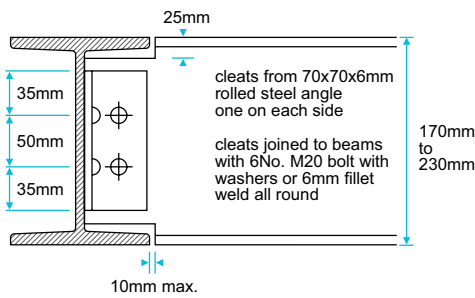
- be in accordance with the guidance in this chapter, or
- where other forms of connection (e.g. high strength friction grip bolts) are required, be designed by an engineer in accordance with Technical Requirement R5.

Only weld, cut or drill steelwork where it is required by the design.

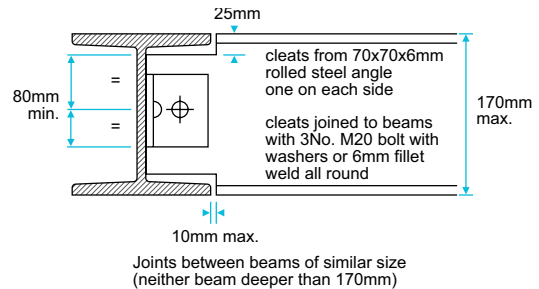
Bolts for connections should comply with the design information and relevant British Standards, including:

<b>BS 4190</b>	'Specification for ISO metric black hexagon bolts, screws and nuts.'
<b>BS 4395</b>	'Specification for high strength friction grip bolts and associated nuts and washers for structural engineering.'
<b>BS 4604</b>	'Specification for use of high strength friction grip bolts in structural steelwork.'
<b>BS 5135</b>	'Specification for arc welding of carbon and carbon-manganese steels.'

The connection methods detailed in this chapter are suitable for connecting steel beams used to support floor loads only, using black bolts or welding.



Joints between beams of similar size  
(beams 170mm to 2390mm deep)



Joints between beams of similar size  
(neither beam deeper than 170mm)

Conditions for the use of this method are:

- beams should only support timber floors in accordance with this chapter
- both beams have been chosen from Table 3
- beams do not differ in depth by more than 40mm.

Connections between steel sections should be designed by an engineer in accordance with Technical Requirement R5, where the above conditions are not met.

### Examples <sup>6.5.7</sup>

1 Using information about the supported wall and Table 1:

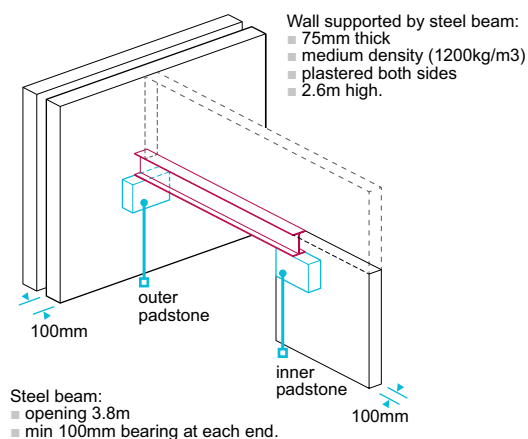
- load per metre run = 4.2kN/m

2 Using the load per metre run, the span of the beam and Table 2:

- suitable section size = 178 x 102 x 19 UB

152 x 152 x 23 UC is not suitable as it is too wide for the inner padstone/wall.

3 Using information about the wall supporting the beam (100mm thick), the walls supported by the beam (medium density block) and Table 6:



Results from example calculation:

<b>Minimum padstone size</b>	155mm long 150 mm deep
<b>Outer padstone (beam at right angles to wall)</b>	
Minimum length	155mm long <sup>(1)</sup>
Minimum depth	150mm
Thickness	100mm, to match blockwork <sup>(2)</sup>
<b>Inner padstone (beam in line with the wall)</b>	
Minimum length	200mm (see note 2 to Table 6)
Minimum depth	150 mm
Thickness	100mm, to match blockwork.

Notes

- 1 This is greater than the flange dimension of the steel section obtained in 2 above – 102mm – therefore a padstone is required to distribute the load.
- 2 The actual length and depth of a padstone could be greater to suit masonry coursing.

# Staircases

## CHAPTER 6.6

This chapter gives guidance on meeting the Technical Requirements for staircases.

6.6.1	Compliance	01
6.6.2	Provision of information	01
6.6.3	Fire precautions	01
6.6.4	Lighting	01
6.6.5	Safe transmission of loads	01
6.6.6	Headroom and width	02
6.6.7	Design of steps	02
6.6.8	Landings	04
6.6.9	Guarding	04
6.6.10	Handrails	05
6.6.11	Timber staircases	05
6.6.12	Timber and wood-based products	06
6.6.13	Finished joinery	06
6.6.14	Concrete staircases	06
6.6.15	Steel staircases	07
6.6.16	Staircase units	07
6.6.17	Fixings	07
6.6.18	Protection	07



Raising Standards. Protecting Homeowners

### Compliance <sup>6.6.1</sup>

*Also see: Chapter 2.1*

#### Staircases shall comply with the Technical Requirements.

Staircases which comply with the guidance in this chapter will generally be acceptable.

### Provision of information <sup>6.6.2</sup>

#### Designs and specifications shall be produced in a clearly understandable format, include all relevant information and be distributed to appropriate personnel.

Design and specification information should be issued to site supervisors, relevant specialist subcontractors and suppliers, and include the following information:

- Layout of stairs.
- Dimensions covering width, rise and going, handrail height, etc.
- Fixing details of stairs, treads, risers, strings, balustrades, newel posts and handrails.
- The length of time before formwork can be removed from in-situ concrete stairs.
- Curing times of grouted connections.

### Fire precautions <sup>6.6.3</sup>

#### Staircases shall provide the necessary means of escape in case of fire.

Timber staircases are acceptable in a single family home where there are no more than four storeys, excluding the basement.

Houses of three or more storeys, and flats in buildings of three or more storeys, should comply with the relevant building regulations.

Ventilation of staircases serving flats in buildings of three or more storeys should comply with BS 9999.

### Lighting <sup>6.6.4</sup>

*Also see: Chapter 8.1*

#### Staircases shall have lighting provided to ensure safe use of the staircase.

Artificial light sources should be provided to all staircases and landings within homes and common areas, and be controlled by two-way switching. In common areas, automatic light-sensitive controls may be used, provided lights can also be switched to two-way manually.

Where staircases are lit by glazing, any glass below the minimum guarding height should be:

- protected by a balustrade or railing
- glass (toughened or laminated), or
- constructed of glass blocks.

### Safe transmission of loads <sup>6.6.5</sup>

#### Staircases shall be properly supported and transmit loads to the supporting structure without undue movement, deflection or deformation. Issues to be taken into account include:

- a) staircase construction
- b) differential movement.

#### Staircase construction

Stairs and staircases should comply with BS 5395 : Parts 1 and 2 and Table 1.

**Table 1:** Standards for stair construction

Type of staircase	Relevant standard
Timber staircases (straight flights, ¼ or ½ landings)	<ul style="list-style-type: none"> <li>■ BS 585.</li> <li>■ The method of fixing flights to the surrounding structure should be specified.</li> </ul>
Reinforced concrete staircases	<ul style="list-style-type: none"> <li>■ BS EN 1992-1-1 and Chapter 3.1 'Concrete and its reinforcement'</li> <li>■ Should be designed by an engineer in accordance with Technical Requirement R5.</li> </ul>
Steel staircases	<ul style="list-style-type: none"> <li>■ BS EN 1993-1-1.</li> </ul>
Proprietary staircases	<ul style="list-style-type: none"> <li>■ Technical Requirement R3.</li> </ul>

### Differential movement

When considering differential movement in relation to setting out, levels and finishes, allowances should be made for:

- casting tolerances
- deflection under load
- foundation settlement
- creep and shrinkage
- storey height.

### Headroom and width <sup>6.6.6</sup>

**Staircases shall ensure adequate provision for:**

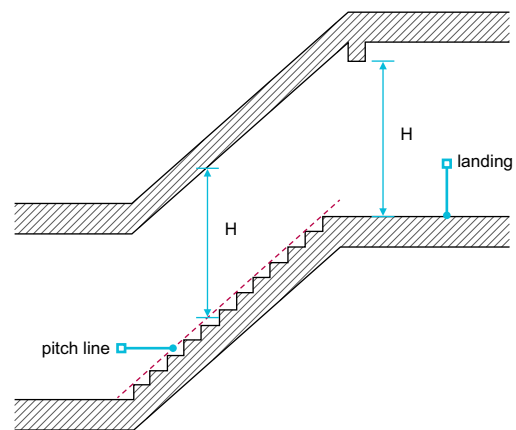
- a) headroom
- b) minimum unobstructed width.

#### Headroom

Stairs should have a minimum 2m clear head room (H) over the entire length and width of the stairway and landing, as measured vertically from the pitch line.

The overall floor opening should be checked:

- for size to accept the stairs
- to allow for sufficient headroom.



#### Minimum unobstructed width

In Northern Ireland and Scotland, stair widths should be in accordance with building regulations.

Where staircases form part of a means of escape, reference should be made to the relevant building regulations.

### Design of steps <sup>6.6.7</sup>

Also see: BS 5395

**Steps shall be constructed to allow the safe use of the staircase. Issues to be taken into account include:**

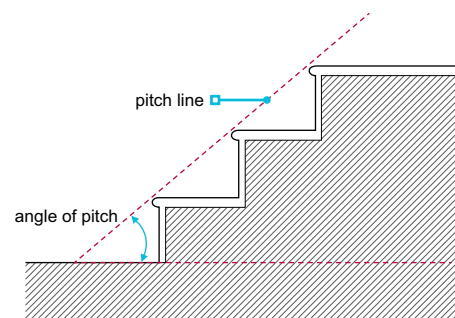
- a) pitch
- b) steps
- c) tapered treads and winders.

#### Pitch

The maximum angle of pitch of a stairway should not exceed:

- 42° for private stairs
- 38° for common or access stairs.

The dimensions for maximum rise and minimum going should be as in Table 2.



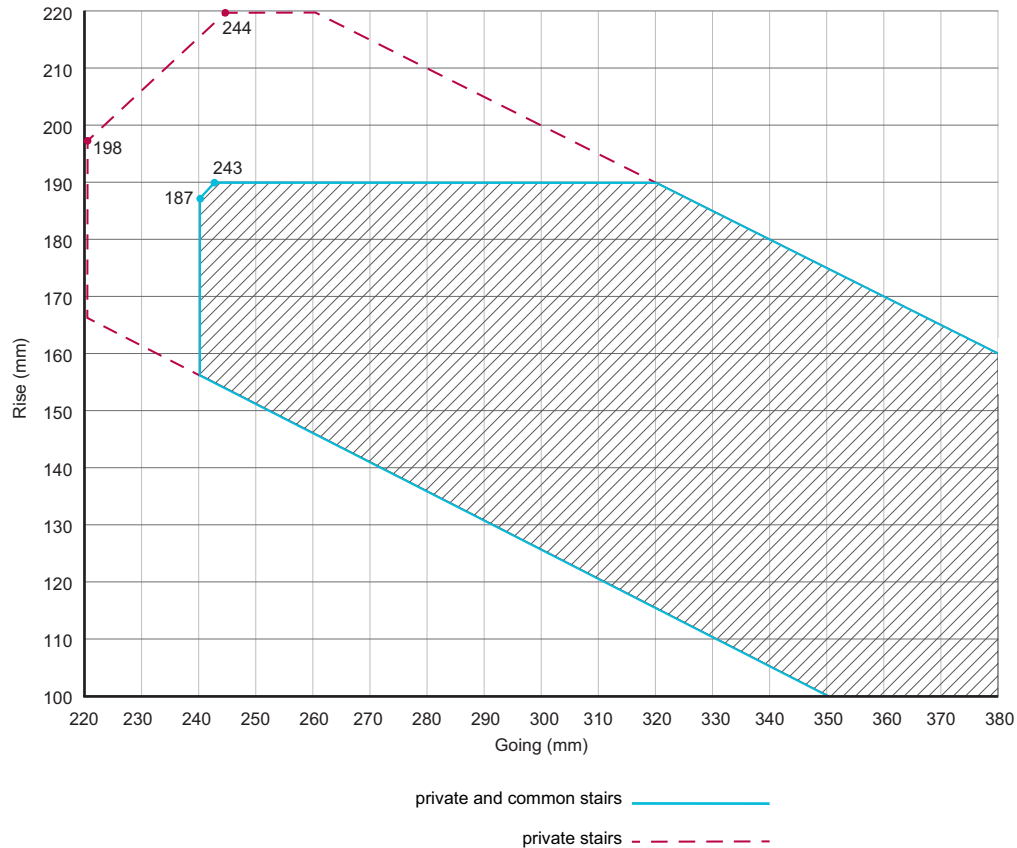
**Table 2:** Maximum rise and going

Type of stairs	Maximum rise (mm)	Minimum going (mm)
Private stairs	220	220
Common stairs (not Scotland)	190	250
Access stairs (Scotland)	190	250

Staircases should be accurately located and fixed with the string at the correct angle to ensure all treads are level.

Stairs should be dimensioned so that the rise (R) and the going (G) is between 550mm and 700mm when using the equation:  $2R + G$  (see Chart 1).

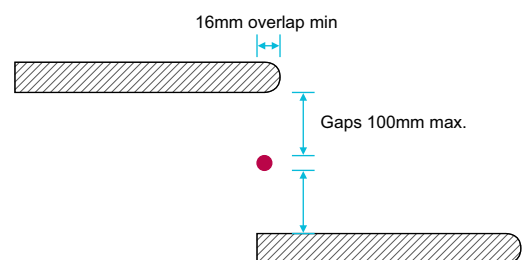
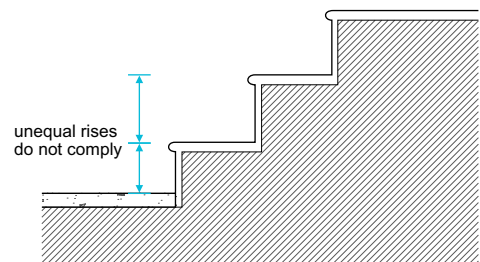
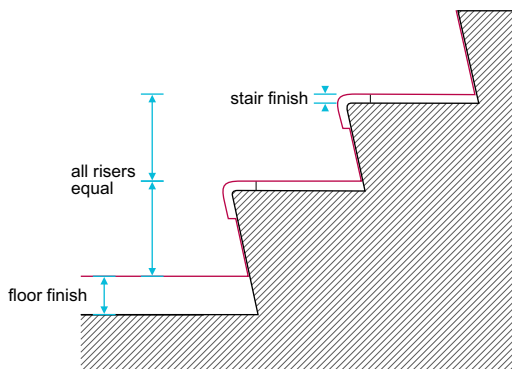
**Chart 1:** Dimensions for rise and going



### Steps

In each flight:

- the tread should be level
- the rise and going should be consistent
- the thicknesses of screeds and floor finishes should be taken into account to ensure that all risers are equal
- the treads should overlap by a minimum of 16mm, where the riser is open.



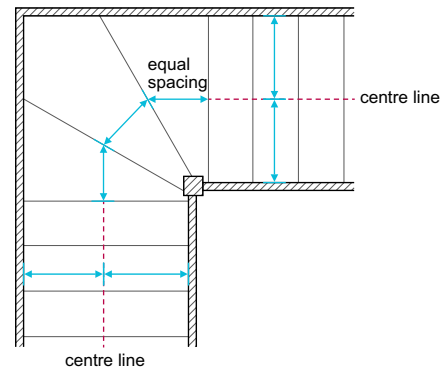
Where stairs are open to the weather, or may otherwise become wet, one of the following should be specified:

- A non-slip finish.
- A non-slip insert to each tread.

### Tapered treads and winders

The rise of tapered treads should be the same as that of adjacent parallel treads. The going should be:

- uniform and no less than the going of the associated straight flight, measured from the centre line of the straight flight
- a minimum of 50mm at the narrowest point.



### Landings <sup>6.6.8</sup>

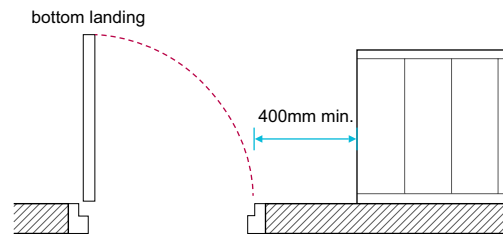
**Landings shall allow safe use of the staircase.**

Landings should be:

- provided at the top and bottom of every flight
- at least the same depth and width as the width of the stair.

Door swings should not obstruct landings. A door may open across the bottom landing of private stairs where the:

- home is not over two storeys high
- the swing is a minimum of 400mm from the first tread.



Pivot windows should not obstruct the landing area or stair flight when they are opened.

### Guarding <sup>6.6.9</sup>

**Staircases shall have guarding to prevent accidents by falling.**

Guarding:

- is required where the drop is more than 600mm at any point along the open sides of stairs and landings
- is not required where the rise is less than 600mm and the stair or landing is not a means of escape
- may be required where a stair abuts an opening window, to comply with relevant building regulations.

Where required, guarding should be:

- provided along the full length of the flight, including landings
- capable of resisting a horizontal force of 0.36kN/m at its minimum required height
- a solid wall or balustrading
- in accordance with Table 3.

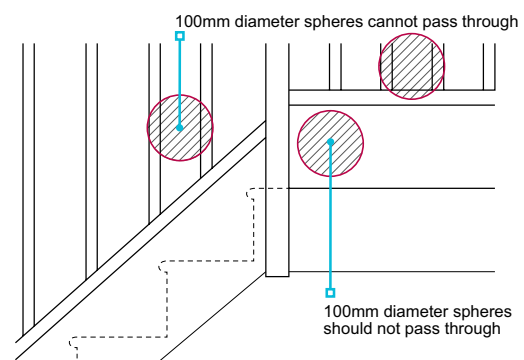
**Table 3:** Guarding height

Type of stairs	Flights – minimum guarding height (mm)	Landings – minimum guarding height (mm)
Private stairs (England, Wales, Northern Ireland and Isle of Man)	900	900
Private stairs (Scotland)	840	900
Common stairs	900	1100

Balustrading should:

- be fixed securely
- not be climbed easily by children
- not have openings larger than 100mm in diameter.

Where guardrails or balustrades are long, newel posts may not be sufficient to transfer the horizontal forces to the structure, and intermediate posts may be required. The method of fixing newels should be specified, e.g. through-bolted to joists.





Where glazing forms part of the guarding it should:

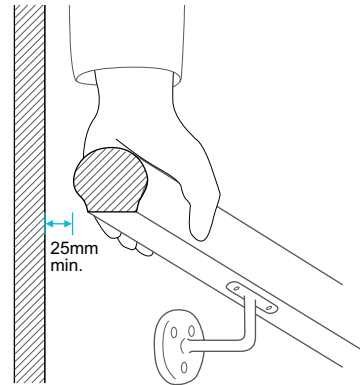
- be toughened, laminated or glass blocks
- not be wired glass.

### Handrails <sup>6.6.10</sup>

**Handrails and balustrading shall be correctly located and fixed to provide a safe handhold, and constructed to reduce the risk of being climbed or fallen through.**

A handrail is required for flights of stairs that rise over 600mm. The handrail (throughout the full length) should:

- be securely fixed and located in accordance with the design
- be a vertical distance of 900mm-1000mm (or 840mm-1000mm in Scotland), above the pitch line
- have a 25mm minimum clearance from any surface
- ensure a firm handhold
- ensure that trapping or injuring is prevented
- have ends shaped or returned to the wall
- be continuous, smooth and unobstructed.



In Northern Ireland, where winders are used, building regulations require a handrail to be fitted on the side where tapered treads have the longest going.

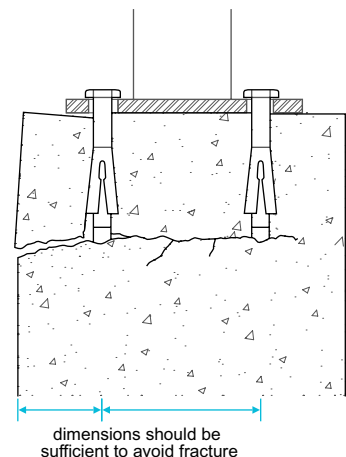
### Fixings

Fixing methods for balustrading should allow for a degree of tolerance. It may be preferable to take measurements from the completed staircase before manufacture. This should ensure that the fixings are positioned correctly and allow for variations in the surrounding structure.

Design information on the spacing of bolt fixings for balustrades or handrails should be followed. Balustrading for concrete staircases may be:

- grouted into preformed holes or pockets
- bolted or screwed into predrilled holes
- bolted to brackets cast into the concrete.

Care should be taken when using expanding fixings near the edges of concrete.



### Timber staircases <sup>6.6.11</sup>

**Timber staircases shall be securely fixed to the supporting structure and have secure component parts.**

The top nosing should be:

- level with the floor decking

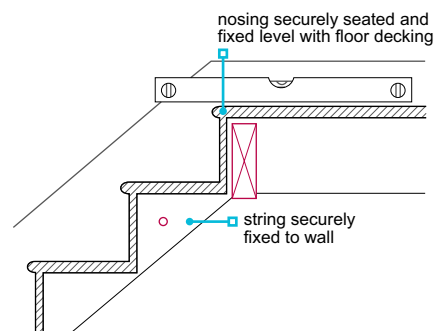
- fixed firmly.

Strings should be:

- glued to newel posts
- secured with dowels or screws.

Landings should be framed to provide full support and solid fixings for the tops of flights, nosings, newels, apron linings, etc.

Newel posts should be plumb, and all components, including strings, treads and risers, newel posts, balustrading and handrails, be fixed securely. Particular attention should be given to fixing winders.



### Timber and wood-based products <sup>6.6.12</sup>

**Staircases shall use timber and wood-based materials of sufficient quality and durability.**

Timber for joinery should:

- comply with BS 1186 : Part 1
- be free of resinous knots, splits, shakes and waness.
- be class 3 or better

The following should meet BS 1186 : Part 2:

- fits of joints
- laminating
- construction of joints
- construction of finger joints
- moving parts
- surface finish.
- gluing

Materials should be in accordance with the guidance given in Table 4.

**Table 4:** Materials for staircases

Material	Requirements
Plywood – should be used for risers only	BS EN 636
Chipboard	BS EN 312 Type 5
Oriented strand board	BS EN 300 OSB3
Fibre building boards	BS 1142 : Part 2
Glued laminated timber structural members	BS 4169

Timber which is to be exposed to the weather should be:

- naturally durable, or
- pretreated with preservative against fungal attack in accordance with Chapter 3.3 'Timber preservation'.

### Finished joinery <sup>6.6.13</sup>

**Staircases shall have finished joinery free from unsightly blemishes.**

Finished joinery should be free from splits, knocks and other damage which would impair its structural performance or finish. Nails should be punched below the surface of the wood and stopped.

Handrails should:

- have a smooth finish and be free from rough edges
- not have any sharp edges, including brackets or screw heads.

### Concrete staircases <sup>6.6.14</sup>

*Also see: Chapter 3.1 and 3.2*

**Concrete staircases shall be suitably constructed using appropriate materials to provide satisfactory performance.**

#### Precast construction

Account should be taken of:

- workmanship, particularly at the top and bottom of each flight
- accurate location and levelling of units.

#### In-situ construction

Guidance for in-situ concrete can be found in Chapter 3.1 'Concrete and its reinforcement'.

Shuttering for concrete elements or connections should be constructed to ensure a consistent rise and going.

Chairs or spacing blocks should be used to provide cover to reinforcement in accordance with Table 5.

**Table 5:** Cover for reinforcement used in concrete stairs

Location	Minimum cover (mm)
Internal staircases	25
Staircases open to the weather	50

Formwork should be struck in accordance with the design information. This is normally:

- after 24 hours for side formwork
- after 28 days for soffit and support formwork.

### Floor Finishes

For both precast and in-situ staircases, allowance should be made for:

- the thickness of finish at the top and bottom of flights
- preformed nosings or non-slip finishes, where specified.

### Steel staircases <sup>6.6.15</sup>

**Steel staircases and the supporting structure shall be set out and constructed in accordance with the manufacturer's instructions.**

For steel staircases:

- the manufacturer's assembly and erection instructions should be available and followed
- the supporting structure should be constructed within relevant tolerance limits set for the steel staircase
- treads should be checked for level
- correct fixings should be used.

### Staircase units <sup>6.6.16</sup>

**Proprietary staircases and associated components shall comply with the design.**

Proprietary staircases and associated components should:

- be as detailed in the design information
- be suitable for their intended location
- comply with Technical Requirement R3.

Manufacturers of staircases and balustrading, etc. should:

- be sent all relevant drawings and other information to ensure their products meet the design requirements
- make allowance for tolerances or actual site dimensions
- use accurate floor-to-floor dimensions
- account for floor finishes to structural floors and staircase treads.

### Fixings <sup>6.6.17</sup>

**Staircases shall have fixings of adequate strength and durability, and comply with the design.**

Fixings should be in accordance with the design and the manufacturer's recommendations, including:

- timber and steel staircases
- newel posts
- handrails
- guarding and balustrading.

### Protection <sup>6.6.18</sup>

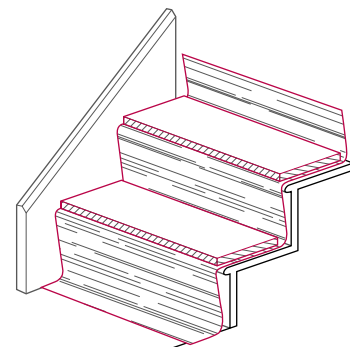
**On completion, staircases shall be undamaged.**

When storing staircases, they should be:

- stacked on bearers
- suitably protected from the weather.

Timber staircases should be fixed in place only when the building is weathertight.

Staircases, stair treads, nosings, balustrades and handrails may be protected with timber strips, plywood or building paper.



# Doors, windows and glazing

## CHAPTER 6.7

This chapter gives guidance on meeting the Technical Requirements for doors, windows and glazing, including where coupled door and window frame assemblies are contained within a single storey.

Coupled door and window frame assemblies (including spandrel panels) which are:

- one storey or more in height, or
  - not contained between a structural floor and ceiling
- should be designed in accordance with Chapter 6.9 'Curtain walling and cladding'.

6.7.1	Compliance	01
6.7.2	Provision of information	01
6.7.3	In service performance	01
6.7.4	Installation	02
6.7.5	Non-timber windows and doors	03
6.7.6	Timber doors and windows	04
6.7.7	Glazing	05
6.7.8	Security	07
6.7.9	Ironmongery	08
6.7.10	Material storage and protection	09
6.7.11	Completed work	09



Raising Standards. Protecting Homeowners

### Compliance <sup>6.7.1</sup>

Also see: Chapter 2.1

**Doors, windows and glazing shall comply with the Technical Requirements.**

Doors, windows and glazing which comply with the guidance in this chapter will generally be acceptable.

### Provision of information <sup>6.7.2</sup>

**Designs and specifications shall be produced in a clearly understandable format, include all relevant information and be distributed to appropriate personnel.**

Design and specification information should be issued to site supervisors, relevant specialist subcontractors and suppliers.

### In-service performance <sup>6.7.3</sup>

**Doors, windows and glazing shall be designed and specified to ensure adequate in-service performance.**

**Issues to be taken into account include:**

- |                     |   |
|---------------------|---|
| a) weathertightness | d) strength   |
| b) fire safety      | e) resistance to movement, shrinkage and the effects of moisture. |
| c) thermal break    |   |

#### Weathertightness

Doors and windows should be installed correctly to ensure adequate in-service performance. Windows and external doors exposed to wind-driven rain should be constructed and detailed to ensure they remain weathertight, including at interfaces with the structure.

BS 6375 contains recommendations for the classification of window components according to their resistance under test to air and water penetration, and wind pressure.

Joints between multiple door and window frame assemblies should be:

- part of an engineered system
- formed using suitable materials in accordance with the manufacturer's recommendations.

Vertical and horizontal DPCs should be provided around the frame in accordance with Chapter 6.1 'External masonry walls' and Chapter 6.2 'External timber framed walls'.

DPCs should:

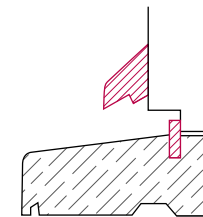
- be correctly installed
- extend approximately 25mm into the cavity
- be continuous for the full height of the frame.

When placing frames for external elements in openings, ensure:

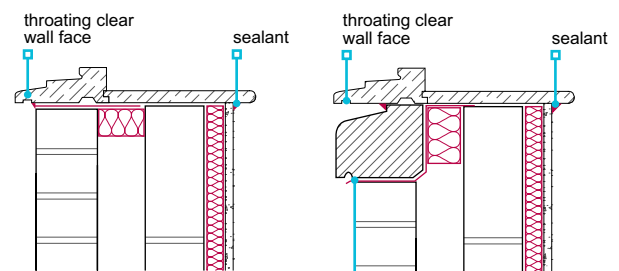
- the head of the frame is protected by the lintel
- throatings in sill members are not obstructed by the wall face.

Additional precautions include:

- setting the frame back from the facade
- building a projecting porch
- providing a rain check groove to inward opening external door frames
- fixing weatherboards and water bars to external doors, but ensuring the threshold is accessible where appropriate.

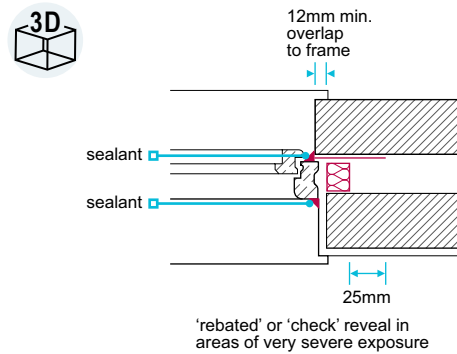


water bar and weatherboard provided for external doors



DPC turned up at back and ends of sills

In Scotland, Northern Ireland and areas of very severe exposure, 'check' reveals should be used, and an appropriate sealant applied between door/window frames and the structure.



### Fire safety

Fire-resisting doors and positive self-closing devices should be fitted where they are required by building regulations.

### Thermal break

Metal windows should incorporate a thermal break.

### Strength

Door frames, windows and their fittings should be adequate to withstand operational loads.

Structural loads should be carried on lintels, beams or appropriate structural elements. Where frames are required to carry structural loads, they should be designed accordingly.

### Resistance to movement, shrinkage and the effects of moisture

Doors and windows should be designed to:

- avoid significant distortion, such as twisting and bowing during use
- take account of timber shrinkage
- be moisture resistant, including window boards.

## Installation <sup>6.7.4</sup>

**Doors and windows shall be correctly located and securely fixed. Issues to be taken into account include:**

- |                                     |                  |
|-------------------------------------|------------------|
| a) workmanship and fixing           | d) door hinges   |
| b) hanging doors and opening lights | e) window boards |
| c) general ironmongery              | f) bay windows.  |

### Workmanship and fixing

Window and door frames should be fixed:

- solidly, level and plumb
- using door/window cramps, or plugged and screwed
- at maximum spacing of 600mm and within 150mm of the top and bottom (alternative locations and fixings are acceptable where they provide the same structural stability)
- using packers at fixing points where required.

Internal door frames and linings should:

- match the thickness of the wall, partitions and finishes
- be blocked off walls wherever possible, to allow for full architraves

Timber trim should be:

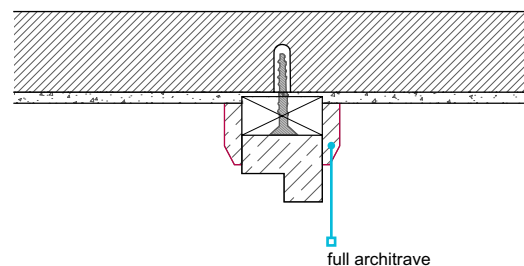
- sufficiently wide to mask joints

Architraves should be:

- parallel to frames and linings
- accurately mitred, or scribed, to fit neatly and tightly

When fixing components:

- nails should be punched below the surface of the timber with holes stopped



- be securely fixed, to prevent curling.
- fixed to minimise movement and shrinkage.
- fixed with an equal margin to each frame member
- fixed securely.
- damage should be avoided.

### Hanging doors and opening lights

Opening lights and door leaves should:

- hang square within the frame or lining
- fit neatly with minimum gaps.

A ventilation grille, or a gap at the bottom of the door may be required for ventilation, in accordance with building regulations.

Where a standard flush door is reduced in height, the bottom rail should be replaced where necessary.

### General ironmongery

Hinges and other ironmongery should be:

- housed neatly and flush with the surface
- supplied with a full set of matching screws.

Locks should:

- turn easily
- have keyholes which are properly aligned
- not be fitted in mortises too tightly

### Door hinges

To reduce twisting, doors should be hung on hinges in accordance with Table 1.

**Table 1:** Door hinges

Type of door	Hinges
External	1½ pairs x 100mm
Internal door	1 pair x 75mm
Fire door	In accordance with the door manufacturer's recommendations
Airing or cylinder cupboard	1½ pairs x 75mm

### Window boards

Window boards should:

- have a flat and level top surface
- be of a moisture resistant grade where MDF is used.
- be fixed close to the frame and adequately secured against twisting and other movement, particularly any back slope towards the frame

### Bay windows

Bay windows should be:

- adequately supported and secured to the structure, to prevent sagging or twisting
- properly linked to DPCs at reveals.

### Non-timber windows and doors <sup>6.7.5</sup>

**Doors and windows of materials other than timber shall be in accordance with the appropriate standards.**

Relevant standards include the following:

<b>BS 4873</b>	Specification for aluminium alloy windows.
<b>BS 6510</b>	Specification for steel windows, window boards and doors.
<b>BS 7412</b>	Plastics windows made from PVC-U extruded hollow profiles.
<b>BS 7413</b>	White PVC-U extruded hollow profiles with heat welded corner joints for plastics windows: materials type A.
<b>BS 7414</b>	White PVC-U extruded hollow profiles with heat welded corner joints for plastics windows: materials type B.

**Timber doors and windows** <sup>6.7.6</sup>

*Also see: Chapter 3.3 and 9.5*

**Timber and wood-based materials shall be of suitable quality and be naturally durable or suitably treated.**

**Issues to be taken into account include:**

- a) classification and use
- b) drying shrinkage
- c) preparation and finish.

**Classification and use**

Timber windows should:

- comply with BS 644
- have a minimum 15mm rebate where double glazed units are to be installed.

Timber and wood-based materials should comply with the relevant requirements of BS EN 942 as follows:

<b>Glazing beads</b>	European
<b>Casements and sash windows</b>	J classes
<b>All other elements</b>	Table 1 of BS EN 942

In England, Wales, Northern Ireland and the Isle of Man, planted stops are not permitted on frames to external doors.

External doors should be 42.5mm minimum (44mm nominal) in thickness.

**Drying shrinkage**

To minimise drying shrinkage, the moisture content of joinery, when fixed, should not exceed the value given in Table 2.

**Table 2:** Moisture content of joinery

Joinery items	Moisture content (%)
Windows and frames	17
Internal joinery:	
■ Intermittent heating.	15
■ Continuous heating.	12
■ In close proximity to a heat source.	9

On delivery, the moisture content should be within +/-2% of the values specified.

**Preparation and finish**

The following elements of timber doors and windows should be of naturally durable timber or timber pretreated against fungal decay:

- External door frames.
- Windows.
- Timber surrounds to metal windows.
- External doors, other than flush doors.

Where material is:

- to be painted, it should be primed before fixing
- to be stained, it should have the first coat applied before delivery to site.

Compatibility between preservative treatment or primer, with glazing compounds, sealants and finishes, should be checked with the relevant manufacturers.

Prefabricated items should comply with the relevant parts of BS 1186 : Part 2, including:

- the fit and construction of joints and moving parts
- the construction of finger joints
- gluing and laminating
- surface finishes.



### Glazing <sup>6.7.7</sup>

**Glass and the method of glazing shall be installed in accordance with the design and to ensure adequate in-service performance. Issues to be taken into account include:**

- |                           |                                  |
|---------------------------|----------------------------------|
| a) standards              | e) condition before installation |
| b) glazing compounds      | f) sizing                        |
| c) glazing systems        | g) rebates                       |
| d) insulating glass units | h) bead glazing.                 |

#### Standards

Where there is a high risk of accidental breakage, glazing should be designed and selected to comply with the relevant safety recommendations as follows:

England, Wales and the Isle of Man	Approved Document N
Northern Ireland	Technical Booklet V
Scotland	BS 6262

Where there is a particular risk (such as door side panels or 'low level' glazing) and where fully glazed panels can be mistaken for doors, toughened or laminated glass, or other materials such as acrylic or polycarbonate, may be required.

The glass supplier should provide documentation to confirm:

- the properties of the glass used
- compliance with the appropriate British Standards.

Glazed materials and units should be:

- compatible with the levels of safety and security that are required
- identified as safety glass with a permanent marking (includes glazed shower/bath screens).

Glazing should ensure adequate in-service performance. The quality and thickness of normal window glass should:

- be specified to suit the design wind loads for the location
- comply with BS 6262 and relevant data sheets issued by the Glass and Glazing Federation.

Glazing and materials should comply with appropriate British Standards, including:

BS 5516	Code of practice for patent glazing
BS 6262	Code of practice for glazing of buildings
BS EN 1279	Glass in buildings-insulating glass units
BS EN 572	Annealed glass
BS EN 14449	Laminated glass
BS EN 12150	Toughened glass
BS EN 572	Wired glass
BS EN 1096	Low-e coated glasses, including hard and soft coated

#### Glazing compounds

Glazing compounds should:

- be compatible with the frame finishes
- be in accordance with the manufacturer's recommendations.

Linseed oil based putty should not be used in the installation of laminated glass or insulating glass units.

#### Glazing systems

##### Drained and vented systems

Drained and vented systems should be used for site fixed insulating glass units and where units greater than 1m<sup>2</sup> are used, to allow moisture that enters the glazing channel between the frame and the edge seal of the insulating glass unit to drain away and prevent long-term moisture contact with the edge seal. Drained and vented systems should have:

- a minimum 5mm gap between the frame's lower rebate and the edge seal of the insulating glass unit
- the edge seal of the insulating glass unit adequately protected.
- adequate drainage and ventilation through holes, slots or channels

### Fully bedded systems

Fully bedded systems are acceptable for factory glazing only where the insulated unit is less than 1m<sup>2</sup>, and should:

- comply with the relevant parts of BS 8000, BS 6262 and BRE Digest 453
- not have gaps around the perimeter of the insulating glass unit.

Partially bedded insulating glass units may be fixed on site where bedded at the top and sides, providing the rebate platform is drained and vented.

### Site glazed systems

Where doors and windows of materials other than timber are delivered to the site unglazed, all glazing should be carried out in accordance with the manufacturer's instructions.

Appropriate fixing and sealing systems should include:

- distance pieces, unless load-bearing tapes are used
- setting blocks
- location blocks, where required
- appropriate beads
- suitable glazing compounds, sealants, gaskets and/or capping.

### Beads

In external situations, the bottom bead should:

- project slightly over the rebate edge
- be fixed to the rebate platform.

### Insulating glass units

Insulating glass units should:

- carry a CE mark to BS EN 1279 and have third-party certification, e.g. BSI Kitemark
- be checked to ensure they comply with the design, including glass type, gas filling, edge seal type and dimensions
- have a dual seal or a single seal of hot melt butyl and desiccant in at least one long and one short section of the spacer bar.

### Condition before installation

Glass and insulating glass units should be inspected for both visual defects and those which could lead to premature failure. Defects can be caused by:

- water accumulating between sheets, which may cause internal surfaces to become marked
- edge damage or scratching.

Insulating glass units should be adequately protected when stored prior to installation.

### Sizing

To account for thermal expansion, the following gaps should be provided:

- 3mm gap between the glass edge and the frame
- 5mm gap at the bottom bead for drained systems.

Insulating glass units should not be cut or punctured on site.

### Rebates

Rebates for glass should be:

- the correct size for the glazing
- primed where timber
- rigid and true.

Insulating glass units should be:

- protected from sunlight at the edges by the frame
- positioned to ensure the spacer bar is below the level of the frame's sightline.

Setting and location blocks should be of a suitable and resilient material.

In drained and ventilated frames:

- dimensions of holes and slots should be checked to ensure that effective drainage can occur
- drainage channels in the rebate should be free from obstructions that could prevent effective drainage.

### Bead glazing

Beads and linings should be used for:

- internal glazing
- locations where shock absorption is required.

Beads should be fixed at a maximum of 150mm centres.

### Security <sup>6.7.8</sup>

**Doors, door frames, windows and locks shall be designed and specified to improve their resistance to unauthorised entry. Issues to be taken into account include:**

- |  |                               |
|--|-------------------------------|
| a) locking functionality of main entrance doors    | e) glazing                    |
| b) locking functionality of secondary access doors | f) framed wall construction   |
| c) opening limitation device                       | g) door and frame connections |
| d) view outside                                    | h) windows.                   |

#### Locking functionality – main entrance doors

##### All homes

Entrance doors of individual homes should be fitted with securely fixed locks or a multi point locking system, which:

- has at least 1000 differs
- if burst open, would not pull out without breaking the door or its frame
- has a hardened steel bolt, or inserts, to prevent sawing
- has a latch and deadlocking facility.

Locking devices fitted to main entrance doors should permit emergency egress without the use of a key when the home is occupied.

##### Homes with an alternative means of escape via a door

- The door should be held closed on a latch.
- Deadlocking should be operated by a key externally and a handle or thumb turn internally (BS 8621 locks and PAS 8621 multi point locks meet these requirements).
- Enhanced security can be achieved by providing the facility to deadlock the internal thumb turn when leaving the home unoccupied (BS 10621 locks and PAS 10621 multi point locks meet these requirements).

##### Homes opening directly to the outside without an alternative means of escape via a door

- The door should be held closed on a latch.
- Deadlocking should be operated by a key externally and a handle or thumb turn internally (BS 8621 locks and PAS 8621 multi point locks meet these requirements).

##### Homes opening onto a communal access without an alternative means of escape

- The door should be held closed with a roller bolt or a latch operated by a handle internally and externally.
- Deadlocking should be operated by a key externally and a handle or thumb turn internally (BS 8621 locks and PAS 8621 multi point locks meet these requirements).

#### Locking functionality – secondary access doors

Side hung doors should:

- be held closed on a latch operated by a handle both internally and externally
- have a deadlocking facility which can be operated by a key both internally and externally; alternatively, a thumb turn may be used internally (BS 3621 or BS 8621 (thumb turn) locks and PAS 3621 or PAS 8621 (thumb turn) multi point locks meet these requirements)
- have bolts securely fixed at both the top and bottom of the door on the internal opening edge (where multi point locking systems are used, bolts may be omitted).

Sliding doors should:

- be secured by way of a multi point locking system with a minimum of three locking points, incorporating mushroom-headed bolts, hook bolts or shoot bolts that engage into the jamb or head, and sill of the door frame
- have an anti-lift device fitted so that doors cannot be lifted from their frame from the outside.

#### Opening limitation device

The main entrance door of individual homes should be fitted with a securely fixed opening limitation device.

In sheltered accommodation, opening limitation devices should not inhibit emergency access. Alternative methods for residents to identify and communicate with visitors without opening their door should be considered.

**View outside**

There should be a means of giving a wide angle view of the area immediately outside the main entrance door of individual homes. Acceptable methods include:

- a through-door viewer
- clear glazing either to part of the door or a convenient window
- closed-circuit camera and displays (not connected to a TV).

**Glazing**

Any glazing which, if broken, would permit release of the internal handle or thumb turn by hand or arm entry should be laminated.

**Framed wall construction**

Lightweight timber or steel framed walls next to doors fitted with locks operated internally with a handle or thumb turn should incorporate either timber sheathing (minimum 9mm thick) or expanded metal, 600mm wide and the full height of the door.

**Door and frame connections**

Connections between door and/or frame components which can be easily released from the outside should not be used. This includes accessible screw connections.

**Windows**

Opening lights on ground floor windows and others which are readily accessible from the outside may be fitted with lockable devices which cannot be released without a key.

**Ironmongery <sup>6.7.9</sup>**

**Ironmongery shall be suitable for the intended use.**

Ironmongery should be provided in accordance with the design. Materials used for critical functions should comply with the appropriate standards, including:

<b>BS EN 1935</b>	'Building hardware. Single-axis hinges. Requirements and test methods'.
<b>BS 3621</b>	'Thief resistant lock assembly. Key egress'.
<b>BS 8621</b>	'Thief resistant lock assembly. Keyless egress'.
<b>BS 10621</b>	'Thief resistant dual-mode lock assembly'.
<b>BS 4951</b>	'Specification for builders' hardware: lock and latch furniture (doors)'.
<b>BS 5872</b>	'Specification for locks and latches for doors in buildings'.
<b>BS EN 1154</b>	'Building hardware. Controlled door closing devices. Requirements and test methods'.

Ironmongery for windows should be supplied as follows:

- Hinges and fastenings of opening lights of windows should be of a type which prevents them from being opened from the outside when in the closed position.
- Where the windows are required by building regulations to have background ventilation, they may be fitted with trickle vents or some other means of providing ventilation which is controllable and located to avoid undue draughts. Windows with 'night vent' positions are not accepted as meeting this requirement.

Where doors to rooms containing a bath or WC have a securing device, it should be of a type capable of being opened from the outside in an emergency.

In sheltered accommodation, additional special provisions may be needed for all door locks, limiters and other fasteners, to enable wardens to gain access when necessary.

### Material storage and protection <sup>6.7.10</sup>

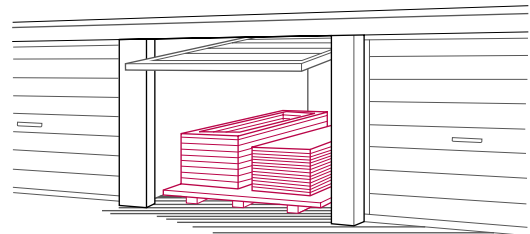
Joinery, door and window components shall be adequately protected against damp and decay. Issues to be taken into account include:

- a) storage
- b) cut ends.

#### Storage

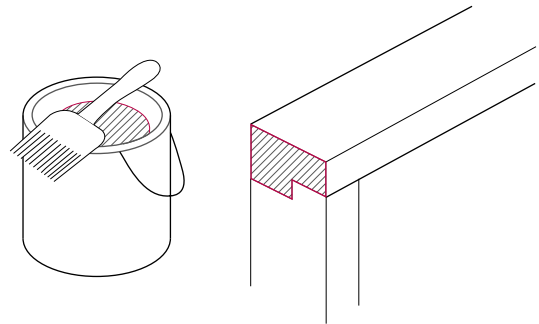
Where joinery is stored on site, precautions should include:

- avoiding wetting during unloading
- stacking external joinery on bearers off the ground and covering with waterproof material
- storing internal joinery in a weather protected condition.



#### Cut ends

Where pretreated joinery is cut or adjusted on site, the affected surfaces should be retreated with appropriate preservative in accordance with the manufacturer's recommendations.



### Completed work <sup>6.7.11</sup>

**Completed work shall be free from damage.**

Work should be to an appropriate level of finish for other trades. Finishing trades should not be relied upon to correct untidy work.

Completed work should be protected as follows:

- Internal doors should be kept covered with polyethylene or original wrapping.
- Door frames and linings should be protected with timber strips or plywood by a minimum of 1m above skirting level.
- Thresholds and window sills should be covered.
- Scaffolding and walkways should be kept away from frames.
- Joinery should be protected from paint splashes and other damage.
- Temporary coverings should be removed after all other work has been completed and before handover.

# Fireplaces, chimneys and flues

## CHAPTER 6.8

This chapter gives guidance on meeting the Technical Requirements for fireplaces, chimneys and flues.

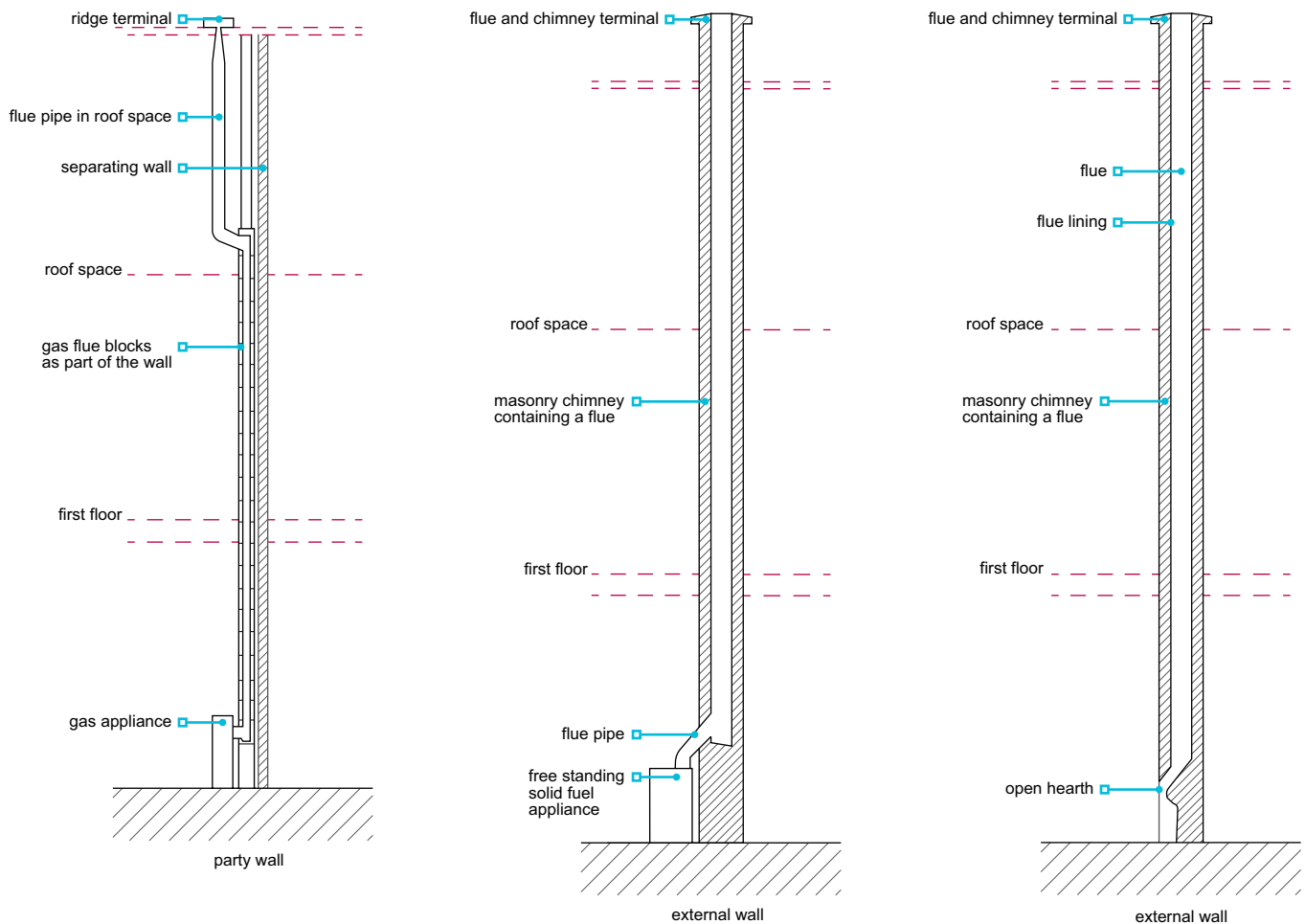
6.8.1	Compliance	01
6.8.2	Provision of information	02
6.8.3	Solid fuel – fireplaces and hearths	02
6.8.4	Solid fuel – combustion air	03
6.8.5	Solid fuel – flue pipes	03
6.8.6	Solid fuel – chimneys	04
6.8.7	Solid fuel – terminals and outlets	05
6.8.8	Gas – fireplaces and hearths	06
6.8.9	Gas – combustion air	07
6.8.10	Gas – flue pipes	07
6.8.11	Gas – chimneys	08
6.8.12	Gas – outlets and terminals	10
6.8.13	Oil – fireplaces and hearths	11
6.8.14	Oil – combustion air	12
6.8.15	Oil – flue pipes	12
6.8.16	Oil – chimneys	12
6.8.17	Oil – outlets and terminals	13
6.8.18	All – fireplaces and hearths	14
6.8.19	All – fireplace surrounds	14
6.8.20	All – flue pipes	15
6.8.21	All – flue liners	15
6.8.22	All – flues	16
6.8.23	All – chimneys	17
6.8.24	Masonry	19
6.8.25	Mortar	19
6.8.26	DPC	19
6.8.27	Flashings	19
6.8.28	Terminals	20
6.8.29	Flue testing	21
6.8.30	Further information	21



Raising Standards. Protecting Homeowners

### Introduction

In this chapter, the following terms are used:



### Compliance <sup>6.8.1</sup>

Also see: Chapter 2.1

**Fireplaces, chimneys and flues shall comply with the Technical Requirements, and be designed to ensure efficient operation of the appliance, an adequate supply of combustion air and protection for the building fabric.**

Fireplaces, chimneys and flues which comply with the guidance in this chapter will generally be acceptable.

Installations should be provided with an adequate supply of combustion air:

- as stipulated by statutory requirements and building regulations
- to ensure satisfactory combustion of fuel and the efficient working of flues and chimneys.

Where a chimney or flue is provided:

- it should be continuous from the hearth or appliance to the outside air
- a notice plate containing safety information about any hearths and flues should be securely fixed in an unobtrusive but obvious position within the home.

The design of homes which incorporate chimneys and flues should ensure that all details of the associated elements are considered and appropriate provisions made. This should include the following:

- Fire risk and separation.
- Hearths and the constructions adjacent to hearths and flues.
- Chimneys and flues, including projections through the building.
- Terminals and outlets.
- Limitations on the appliance or open fire which can be installed, and fuel which can be used.

Good workmanship and effective supervision during construction are essential to ensure that fireplaces, chimneys and flues function correctly in use.

Fireplaces, chimneys and flues should be designed and installed to minimise the risk of the building catching fire. The design of timber frame construction should ensure that combustible material is:

- suitably separated from heat sources, or
- shielded, where permitted.

### Provision of information <sup>6.8.2</sup>

**Designs and specifications shall be produced in a clearly understandable format, include all relevant information and be distributed to the appropriate personnel.**

Clear and fully detailed drawings should be available on site to enable work to be carried out in accordance with the design. Designs and specifications should be issued to site supervisors, relevant specialist subcontractors and suppliers, and include the following information:

- Position and size of hearths, fireplaces, chimneys and flues.
- Position and proximity of combustible materials.
- Position and details of flue terminals or outlets.
- Position of DPCs and flashings.
- Construction details of fireplace openings and chimney connections.
- Details of materials to be used.
- Limitations of the type of appliance or open fire that can be installed and fuel that can be used.
- Details of the tests required on chimneys and flues, including who is responsible for carrying them out.

### Solid fuel – fireplaces and hearths <sup>6.8.3</sup>

**Fireplaces and hearths shall safely accommodate the fire or appliance for which they are designed.**

**Issues to be taken into account include:**

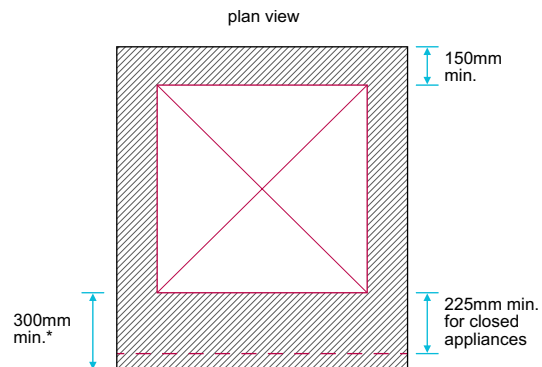
- a) provision of hearths and recesses
- b) separation of hearths from walls.

Where appliances are not provided, it is important to construct fireplaces and hearths to suit the appliance most likely to be fitted.

#### Provision of hearths and recesses

Constructional hearths should be:

- provided for open fires or closed combustion appliances in accordance with building regulations and the manufacturer's recommendations
- a minimum of 840mm in any direction for freestanding appliances
- The adjacent diagram shows the minimum dimensions from the appliance to the edge of the hearth.



Recesses for open fires or closed combustion appliances:

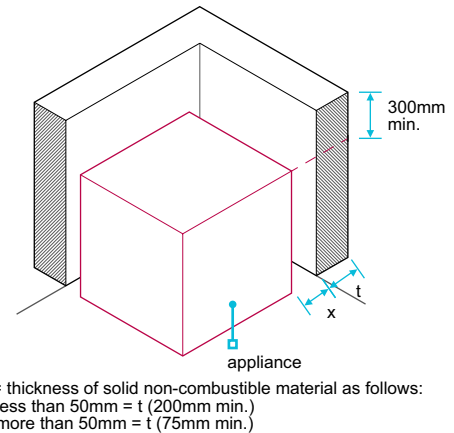
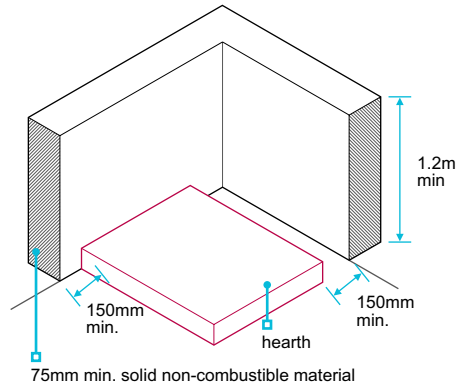
- should be provided to comply with building regulations and the manufacturer's recommendations
- should be lined with a fire back or fire bricks
- where the opening is less than 500mm x 550mm, should have a 200mm diameter flue (or square section flue of an equivalent area)
- where the opening is larger than 500mm x 550mm, should have a flue equivalent to 15% of the recess opening.



### Separation of hearths from walls

Walls near appliances and their hearths should be:

- located to minimise the risk of fire
- non-combustible, or the appliance should not be positioned closer to the wall than as shown in the following diagram.



### Solid fuel – combustion air <sup>6.8.4</sup>

**Installations shall be provided with an adequate supply of combustion air.**

Solid fuel appliances should have an air supply from external air, either directly or indirectly, to comply with statutory requirements and the manufacturer's recommendations. Full details of ventilation requirements for all types of appliances are contained in relevant building regulations.

**Table 1:** Combustion air to solid fuel appliances

	Solid fuel up to 45kW output	
	Open	Closed appliance <sup>(2)</sup>
England, Wales and the Isle of Man	50% of throat area <sup>(1)</sup>	Above 5kW rating, 550mm <sup>2</sup> /kW
Scotland	For fireplaces up to 450mm wide (measured between fire bricks), 1500mm <sup>2</sup> For fireplaces wider than 450mm, manufacturer's details should be followed	Above 5kW rating, 550mm <sup>2</sup> /kW
Northern Ireland	50% of throat area <sup>(1)</sup>	Up to 6kW rating, 550mm <sup>2</sup> Over 6kW, add 550mm <sup>2</sup> for each kW above 6kW

Notes

- 1 Where the fire has a canopy, the open air vents should be 50% of the flue area.
- 2 Where closed appliances use a flue fitted with a draught stabiliser, the total free area should be increased to 300mm<sup>2</sup>/kW for the first 5kW plus 850mm<sup>2</sup>/kW for the balance of the appliance output.

### Solid fuel – flue pipes <sup>6.8.5</sup>

**Flue pipes shall be correctly designed to connect an appliance to a flue safely. Issues to be taken into account include:**

- a) size, direction and jointing
- b) separation from combustible materials.

#### Size, direction and jointing

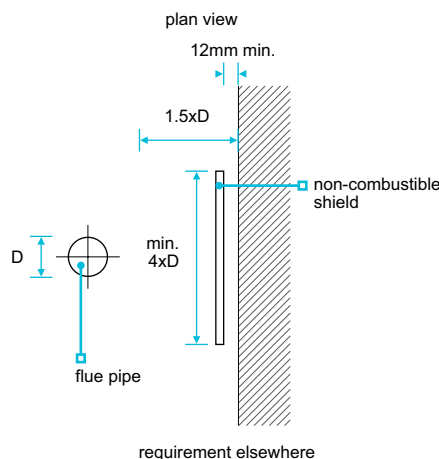
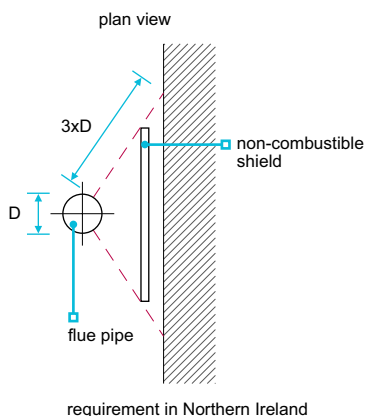
Flue pipes should have a cross-section which is equal to the outlet of the appliance they serve and should not be inclined more than 45° from vertical. A horizontal section no longer than 150mm may be used to connect a back outlet appliance to a flue.

Socket joints should be fitted socket up.

#### Separation from combustible materials

Flue pipes should be separated from combustible materials in accordance with building regulations, and:

- by a minimum 200mm of non-combustible material
- by an air space which is a minimum of 4xD, or
- be shielded by a non-combustible shield at least 4xD in width, and extended at least 1.5xD either side of the flue pipe; the shield should be at least 12mm from the combustible material, and the flue pipe at least 1.5xD from the combustible material.



(D = external diameter of the flue pipe)

### Solid fuel - Chimneys <sup>6.8.6</sup>

**Chimneys shall incorporate flues capable of safely conducting products of combustion to the external air. The structure shall be capable of supporting the flue lining and shall provide adequate protection to the adjacent structure. Issues to be taken into account include:**

- |  |                               |
|--|-------------------------------|
| a) separation from adjacent spaces and materials | c) resistance to frost attack |
| b) flue liners                                   | d) resistance to weather.     |

Flues for solid fuel appliances should:

- not serve more than one appliance
- be of a sufficient cross-section to remove all combustion gases from the open fire or appliance they serve
- where possible, be vertical (where this cannot be achieved there should not be more than two bends; bends should not be more than 45° from vertical)
- be a minimum of 4.5m high (measured above the fireplace opening).

Where a chimney is not directly over an appliance or opening, an accessible soot box should be formed.

Factory-made insulated chimneys should:

- be designed in accordance with BS 4543 and BS EN 1859
- be installed in accordance with BS 7566 or be assessed in accordance with Technical Requirement R3.
- have a minimum operating life of 30 years

#### Separation from adjacent spaces and materials

Combustible materials close to any brickwork or blockwork chimney (not applicable to floorboards, skirting, dado or picture rails, mantelshelves or architraves) should be:

- a minimum of 200mm from the inside surface of the flue, or
- in all areas except Scotland, 40mm from the face of the chimney.

Where the home is of timber frame construction, full details of the separation proposal should be included in the design.

Materials used for chimneys should be capable of resisting fluctuating temperatures up to 1100°C.

Flues should be formed within masonry walls. The walls should be:

- a minimum of 100mm thick, or
- a minimum of 200mm thick where separating the flue from another compartment of the same building, another building or another home.

Where there is more than one flue in a chimney, the flues should be separated by a minimum of 100mm of masonry.

#### Flue liners

Flue liners should:

- have rebated or socketed joints installed with the socket or internal rebate facing uppermost
- be installed in accordance with the manufacturer's recommendations
- be non-combustible
- be properly jointed at their junctions with the starter block, or lintel, and the outlet terminal
- be reasonably smooth on the inside
- be correctly jointed with mortar (the space between the liners and the brickwork should be filled with weak insulating concrete unless the manufacturer recommends an alternative)
- have any changes in direction formed using purpose-made bends (cut pipes are not acceptable).

### Resistance to frost attack

Where clay brick chimneys are above roof level and are not protected by a capping with an adequate overhang and drip (see Clause 6.8.7c), the chimney should be constructed using F2,S1 or F2,S2 bricks to BS EN 771. They should be bedded in mortar, either:

- 1:½:4 to 4½, cement:lime:sand, or
- 1:3 or 4, cement:sand with plasticiser.

Where external chimneys built with clay bricks of F2,S1 designation are rendered, sulfate-resistant cement should be used.

In Scotland, external facing brickwork should be constructed using frost-resistant bricks.

### Resistance to weather

In areas of severe or very severe exposure, cavities should be continuous up to roof level. This applies to:

- cavities below roof level where the stack forms part of an external cavity wall
- the complete chimney structure, including the fireplace recess.

In areas of severe or very severe exposure, and where the chimney breast is gathered in, the lower projecting masonry should be protected against damp penetration with a suitable capping and cavity trays (see Clause 6.8.28b).

Above the roof:

- chimney DPCs should link with flashings; where the roof is steeply pitched (where the difference in level between the lower and higher intersection of the chimney with the roof will be more than 450mm) two DPCs should be used at suitable levels
- plastic DPCs are not suitable
- face brickwork should not have recessed joints
- where lead trays are in contact with mortar, they should be protected with a thick coat of bitumen or bitumen paint
- where chimneys are to be rendered, render should be in accordance with Chapter 6.11 'Render'.

### Solid fuel – outlets and terminals <sup>6.8.7</sup>

**Outlets and terminals shall be adequately separated from combustible material and other parts of the home, enable the satisfactory discharge of flue gases and prevent the ingress of damp. Issues to be taken into account include:**

- a) outlet position
- b) terminals
- c) chimney cappings.

#### Outlet position

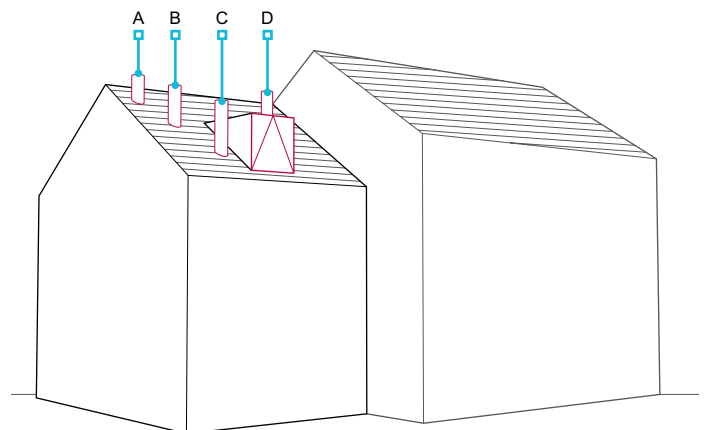
The flue will generally function more effectively where the outlet is in a low pressure zone, taking account of prevailing winds.

A low pressure zone generally occurs:

- on the lee side and at the ridge of a pitched roof
- close to the windward side of a flat roof.

Where the efficiency of the flue may be affected by adjacent trees or buildings in the 'low pressure' zone, the design should account for their effects.

Where down draughts occur, e.g. on hillsides or near tall trees and buildings, the height of the flue outlet may have to be increased or a fan-assisted flue installed.



**Table 2:** Positions of outlets for solid fuel appliances

	Point where flue passes through weather surface <sup>(1 &amp; 2)</sup>	Minimum clearance from the flue outlet
<b>A</b>	Up to 600mm from ridge	Over 600mm above the ridge
<b>B</b>	Elsewhere on a roof (whether pitched or flat)	A minimum of 2.3m horizontally from the nearest point on the weather surface and: ■ a minimum of 1m above the highest point of intersection of the chimney and the weather surface, or ■ as high as the ridge
<b>C</b>	Below (on a pitched roof) or within 2.3m horizontally from an openable rooflight, dormer window or other opening <sup>(3)</sup>	A minimum of 1m from the top of the opening
<b>D</b>	A minimum of 2.3m to adjoining or adjacent building, whether or not beyond the boundary <sup>(3)</sup>	A minimum of 600mm above the adjacent building

**Notes**

- 1 The weather surface is the building's external surface, such as its roof, tiles or external walls.
- 2 A flat roof has a pitch less than 10°.
- 3 The clearance given for A or B, as appropriate, will also apply.

**Terminals**

Terminals should be:

- purpose-made components
- sealed to the flue liner.
- built into the top of the masonry to a minimum of 125mm or 0.25x the length of the terminal, whichever is the greater

An acceptable terminal can be achieved where the top flue liner projects a minimum of 20mm above the chimney capping.

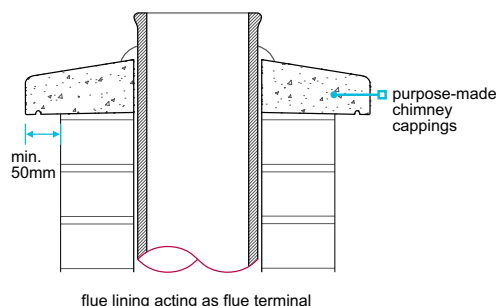
**Chimney cappings**

Chimney cappings should:

- be weathered, monolithic slabs
- be designed to protect the masonry below
- project a minimum of 50mm, and have a drip to shed water clear of the masonry.

Cappings may be designed as a cover slab supported on piers (to reduce rain penetration into the top of the flue). The height of the supporting piers should be sufficient to allow a free opening equivalent to a minimum of 2x the area of the flue outlet.

Brick chimneys which do not have this type of capping should be constructed using frost-resistant masonry.



**Gas – fireplaces and hearths <sup>6.8.8</sup>**

**Fireplaces and hearths shall safely accommodate the fire or appliance for which they are designed. Issues to be taken into account include:**

- a) separation from combustible materials
- b) provision of hearths and recesses.

Gas appliances should be:

- fitted by a Gas Safe Register (GSR) installer, and
- comply with the Gas Safety (Installation and Use) Regulations 1998.

**Separation from combustible materials**

Appliances should not be closer than 75mm to combustible material. This applies to:

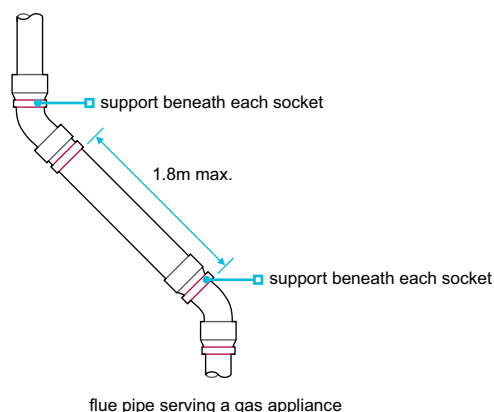
- the back, sides and top of the appliance
- draught-diverters.

It does not apply:

- where a 25mm thick non-combustible shield is used, or
- the appliance complies with the appropriate parts of BS 5258 or BS 5386.



When connecting flue pipes to flue blocks and ridge terminals, purpose-made connections should be used.



### Separation from combustible materials

Single wall flue pipes should be separated from combustible materials by:

- a minimum of 25mm
- a non-combustible casing material with at least half the fire resistance of the separating wall or floor, where they pass through a compartment wall or compartment floor, or
- a non-combustible sleeve with a minimum 25mm air space around the pipe, where it passes through a wall, floor or roof.

Where double-walled pipes are used, the 25mm separation distance may be measured from the outside of the inner pipe.

### Gas – chimneys <sup>6.8.11</sup>

**Chimneys shall incorporate flues capable of safely conducting products of combustion from an appliance to the external air. The structure shall be capable of supporting the flue and providing adequate protection to adjacent materials. Issues to be taken into account include:**

- a) flues and flue liners
- b) chimneys.

### Flues and flue liners

Flue blocks for use with gas appliances should comply with BS1289-1 (Concrete) or Part 2 (Clay).

**Table 4:** Gas flue sizes

	Serving	Minimum flue size
Non fan-assisted individually flued gas burning appliances up to 70kW input, excluding balanced flue	Gas fire	Either: <ul style="list-style-type: none"> <li>■ acircular flue with a minimum 12000mm<sup>2</sup> cross-sectional area (125mm diameter), or</li> <li>■ a rectangular flue with a minimum 16,500mm<sup>2</sup> cross-sectional area and a minimum dimension of 90mm</li> </ul>
	Any other	■ At least the cross-sectional area of the outlet from the appliance
Inset live or decorative gas fuel effect appliances	Open fire within a fireplace opening up to 500mm x 550mm	■ Either a circular or rectangular flue with a minimum dimension of 175mm

Flue liners should comply with BS 715 or be as described in Clause 6.8.6. Flexible flue liners are not acceptable in a new build.

### Chimneys

Chimneys for gas appliances must not incorporate an adjustable draught control.

#### Masonry chimneys

Flues within masonry chimneys should be in accordance with the requirements relevant to flues for solid fuel appliances (see Clause 6.8.6b).

Brickwork or blockwork chimneys for gas appliances should, at minimum, have the same level of fire resistance as each compartment wall or floor which it forms part of, or passes through. The compartment wall may form the chimney wall where it is a masonry material.

Terminals to masonry chimneys should:

- where proprietary, comply with BS 715, BS EN 1858 and the appliance manufacturer's recommendations
- where proprietary products are not used, have a free opening area a minimum of 2x the area of the flue; there should be openings (6-25mm in diameter) distributed uniformly around the terminal or on two opposite faces.

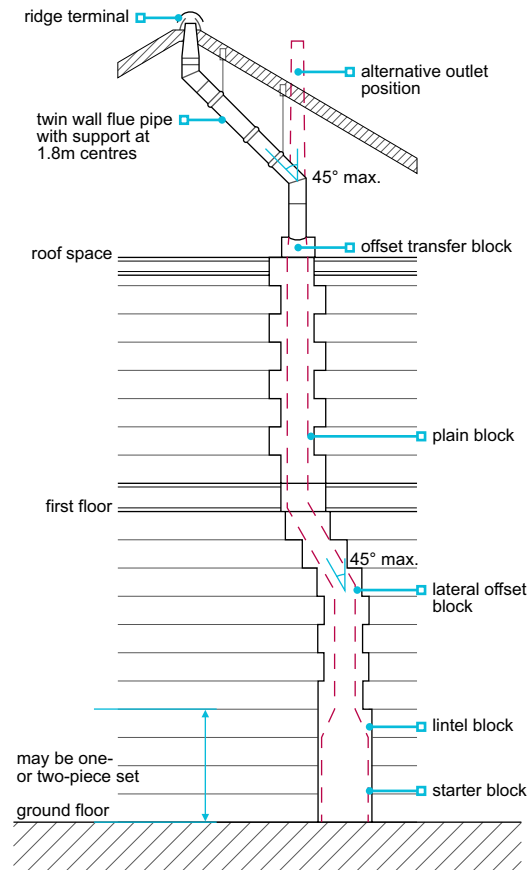
### Flue block chimneys

Flue block chimneys can only be used for certain types of gas appliances and should be:

- compliant with BS EN 1858 or BS EN 1806 with a minimum performance class of FB4 N2
- constructed using units suitable for the appliance
- constructed, jointed and weatherproofed in accordance with the design and the manufacturer's instructions
- correctly bonded to the flanking masonry
- clean and sealed
- checked for suitability, before connecting any appliance.

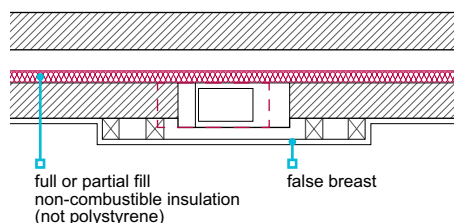
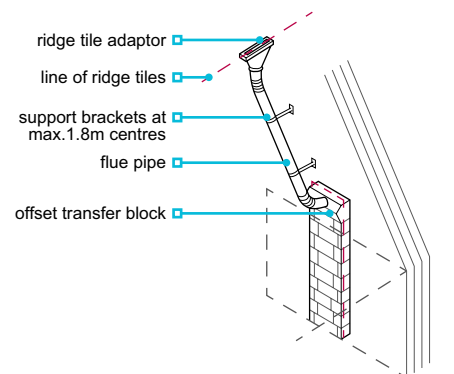
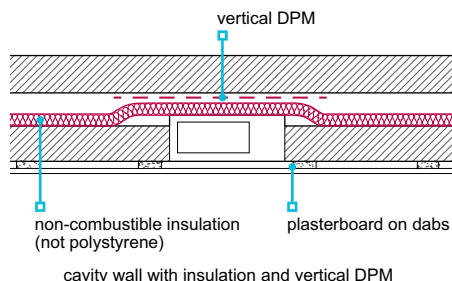
Connections between flue blocks and ridge terminals should be made:

- in accordance with the design
- using the correct fittings and supports as specified by the manufacturers of the flue blocks, flue pipe and ridge terminal.



Gas flue blocks are at least 140mm wide. Where this is wider than the wall leaf:

- the extra thickness should be incorporated by increasing the overall width of the cavity
- the flue block should be installed flush with the inside of the cavity and project into the room as a false chimney breast, or
- where the cavity is reduced, the flue block should be protected by a vertical DPM supported by a layer of non-combustible insulation, in accordance with the manufacturer's instructions.



Flue blocks should not be:

- built into separating walls unless it can be shown that the wall has adequate sound resistance
- plastered; a plasterboard lining with an air space or non-combustible insulation behind it should be provided (insulated dry lining may be unsuitable in this situation unless separated from the flue block).

**Factory-made insulated chimneys**

Factory-made insulated chimneys should:

- be assembled, erected, anchored and protected in accordance with the manufacturer's instructions
- comply with BS 4543 and be installed in accordance with BS 6461, or
- BS 715 and installed in accordance with BS 5440.

**Gas – outlets and terminals <sup>6.8.12</sup>**

**Outlets and terminals shall be adequately separated from combustible material and other parts of the home, and prevent the ingress of damp.**

**Table 5:** Minimum separation distances for gas outlets (mm)

Location	Balanced flue		Open flue	
	Natural draught	Fanned draught	Natural draught	Fanned draught
<b>A</b> Below an opening <sup>(1)</sup>	Appliance rated heat input (net)		<sup>(3)</sup>	300
	0-7kW	300		
	>7-14kW	600		
	>14-32kW	1500		
	>32kW	2000		
<b>B</b> Above an opening <sup>(1)</sup>	0-32kW	300	<sup>(3)</sup>	300
	>32kW	600		
<b>C</b> Horizontally to an opening <sup>(1)</sup>	0-7kW	300	<sup>(3)</sup>	300
	>7-14kW	400		
	>14kW	600		
<b>D</b> Below gutters, soil pipes or drain pipes	300		<sup>(3)</sup>	75
<b>E</b> Below eaves	300		<sup>(3)</sup>	200
<b>F</b> Below a balcony or car port roof	600		<sup>(3)</sup>	200
<b>G</b> From a vertical drainpipe or soil pipe	300		150 <sup>(4)</sup> <sup>(3)</sup>	150
<b>H</b> From an internal or external corner, or to a boundary alongside the terminal <sup>(2)</sup>	600		<sup>(3)</sup>	200
<b>I</b> Above ground, roof or balcony level	300		<sup>(3)</sup>	300
<b>J</b> From a surface or a boundary facing the terminal <sup>(2)</sup>	600		<sup>(3)</sup>	600
<b>K</b> From a terminal facing the terminal	600		<sup>(3)</sup>	1200
<b>L</b> From an opening in the car port into the building	1200		<sup>(3)</sup>	1200
<b>M</b> Vertically from a terminal on the same wall	1200		<sup>(3)</sup>	1500
<b>N</b> Horizontally from a terminal on the same wall	300		<sup>(3)</sup>	300
<b>P</b> From a structure on the roof	N/A	N/A	1500 (for a ridge terminal) 2000 (for any other terminal, as given in BS 5440-1)	N/A
<b>Q</b> Above the highest point of intersection with the roof	N/A	Site in accordance with manufacturer's instructions	Site in accordance with BS 5440-1:2000	150

Notes

- 1 An opening here means an openable element, such as an openable window, or a fixed opening, such as an air vent. However, in addition, the 1 outlet should not be nearer than 150mm (fanned draught) or 300mm (natural draught) to an opening into the building fabric formed for the purpose of accommodating a built-in element, such as a window frame.
- 2 Boundary as defined in paragraph 0.4. of Approved Document J: smaller separations to the boundary may be acceptable for appliances that have been shown to operate safely with such separations from surfaces adjacent to, or opposite, the flue outlet.
- 3 Should not be used.
- 4 This dimension may be reduced to 75mm for appliances of up to 5kW input (net).

Where a flue outlet is not serving a balanced flue appliance, it should be:

- situated at roof level, so that air can pass freely across it at all times
- a minimum of 600mm from openings
- fitted with a flue terminal where the flue diameter is less than 170mm (larger diameter flues should be fitted with a terminal where required by Building Regulations).





**Oil – combustion air** <sup>6.8.14</sup>

**Installations shall be provided with an adequate supply of combustion air.**

**Table 6:** Combustion air to oil appliances

	Oil up to 45kW output
England, Wales and the Isle of Man	550mm <sup>2</sup> /kW above 5kW rating for an appliance in a room or space
Scotland	
Northern Ireland	Up to 6kW rating, 550mm <sup>2</sup> . Over 6kW, add 550mm <sup>2</sup> for each kW above 6kW

**Oil – flue pipes** <sup>6.8.15</sup>

**Flue pipes shall safely connect an appliance to a chimney.**

Flue pipes should:

- have a free area which is at least the same size as the outlet of the appliance
- be vertical where possible, or no more than 45° from vertical; a horizontal section, less than 150mm, long may be used to connect a back outlet appliance to a flue.

**Oil – chimneys** <sup>6.8.16</sup>

**Chimneys shall incorporate flues capable of safely conducting products of combustion from an open fire or other appliance to the external air. The structure shall be capable of supporting the flue lining and shall provide adequate protection to adjacent materials. Issues to be taken into account include:**

- |   |  |
|---|--|
| a) stability, size and direction  | c) flue liners                         |
| b) separation from adjacent spaces, materials and combustible materials | d) resistance to frost/chemical attack |
|   | e) resistance to weather.              |

**Stability, size and direction**

Flue pipes should:

- have a free area which is at least the same size as the outlet of the appliance
- where possible, be vertical (where this cannot be achieved, there should be no more than two bends, which should not be more than 45° from vertical).

Factory-made insulated chimneys should:

- be designed in accordance with BS 4543 : Part 1 to Part 3 and BS EN 1859 and installed in accordance with BS 7566 : Part 2, or be assessed in accordance with Technical Requirement R3
- have a minimum operating life of 30 years
- where they are part of a component system, comply with BS 715 and installed in accordance with BS 5440.

**Separation from adjacent spaces, materials and combustible materials**

**Table 7:** Protecting buildings from hot flues for flue gas temperatures not more than 250°C

Flue within:	Protection measures
Connecting fluepipe	Flues should be a minimum of 25mm from any combustible material. This is measured from the outer surface of the flue wall and the inner wall of multi-walled products.
Factory-made chimney complying with BS 715:1993	Where flues pass through a combustible wall, floor or roof (other than a compartment wall, floor or roof) separation can be achieved through the use of a non-combustible sleeve around the fluepipe or chimney with a 25mm air space to the relevant flue wall. The air space could be wholly, or partially, filled with non-combustible insulating material.
Factory-made chimney complying with: BS 4543-1 (withdrawn April 2000 partially superseded by <ul style="list-style-type: none"> <li>■ BS 4543-2</li> <li>■ BS 4543-3</li> </ul>	Refer to appropriate British Standards and manufacturers recommendations.
Masonry chimney	Provide a minimum of 25mm of masonry between flues and any combustible material.
Flue block chimney	Provide flue block walls a minimum of 25mm thick.
Flue assemblies for roomed-sealed appliances	Flues passing through combustible walls should be surrounded by a minimum of 50mm insulating material. Provide a minimum clearance of 50mm from the edge of the flue outlet to any combustible wall cladding.

### Flue liners

As for gas flue pipes where the flue gases are unlikely to exceed a temperature of 250°C (see Clause 6.8.10). As for solid fuel flue pipes where the flue gases are likely to exceed a temperature of 250°C or the temperature is not known (see Clause 6.8.5).

Flexible flue liners are not acceptable for new build.

### Resistance to frost/chemical attack

Resistance to frost attack as for solid fuel (see clause 6.8.6).

### Resistance to weather

Resistance to weather as for solid fuel (see clause 6.8.6).

## Oil – outlets and terminals <sup>6.8.17</sup>

**Outlets and terminals shall be adequately separated from combustible material and other parts of the home.**

Balanced flue terminals should be positioned to allow free intake of air to the appliance.

Where terminals are of masonry construction, they should be in accordance with the requirements for solid fuel appliances (see Clause 6.8.7b), otherwise they should be in accordance with the manufacturer's recommendations.

**Table 8:** Minimum separation distances for oil terminals

Location of outlet <sup>(1)</sup>		Appliance with pressure jet burner (mm)	Appliance with vaporising burner (mm)
A	Below an opening <sup>(2 &amp; 3)</sup>	600	Should not be used
B	Horizontally to an opening <sup>(2 &amp; 3)</sup>	600	
C	Below a plastic/painted gutter, drainage pipe or eaves, where combustible material protected <sup>(4)</sup>	75	
D	Below a balcony or a plastic/painted gutter, drainage pipe or eaves without protection to combustible material	600	
E	From vertical sanitary pipework	300	
F	From an external or internal corner, or from a surface or boundary alongside the terminal	300	
G	Above ground or balcony level	300	
H	From a surface or boundary facing the terminal	600	
J	From a terminal facing the terminal	1200	
K	Vertically from a terminal on the same wall	1500	
L	Horizontally from a terminal on the same wall	750	
M	Above the highest point of an intersection with the roof	600 <sup>(6)</sup>	1000 <sup>(5)</sup>
N	From a vertical structure to the side of the terminal	750 <sup>(6)</sup>	2300
O	Above a vertical structure which is less than 750mm (pressure jet burner) or 2,300mm (vaporising burner) horizontally from the side of the terminal	600 <sup>(6)</sup>	1000 <sup>(5)</sup>
P	From a ridge terminal to a vertical structure on the roof	1500	Should not be used

#### Notes

- Terminals should only be positioned on walls where appliances have been approved for such configurations when tested in accordance with BS EN 303-1 or OFTEC standards OFS A100 or OFS A101.
- An opening means an openable element, such as an openable window, or a permanently open air vent.
- Notwithstanding the dimensions above, a terminal should be at least 300mm from 3 combustible material, e.g. a window frame.
- To provide protection to combustible material, fit a heat shield at least 4750mm wide.
- Where a terminal is used with a vaporising burner, the terminal should be at least 2.3m horizontally from the roof.
- Outlets for vertical balanced flues in locations M, N and O should be in accordance with 6 manufacturer's instructions.

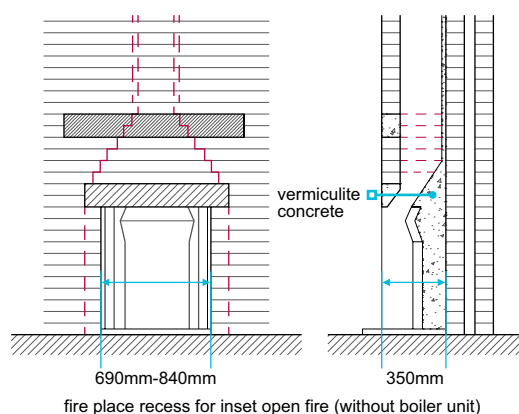
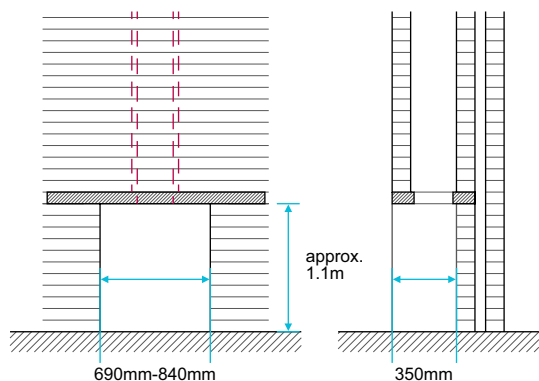
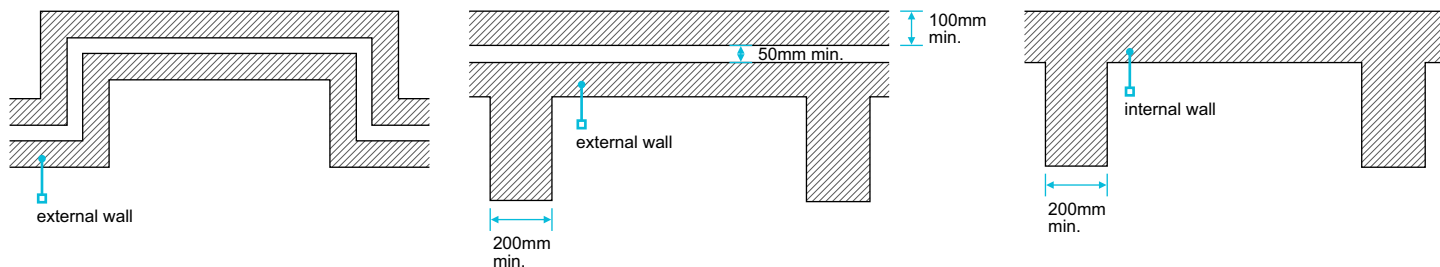
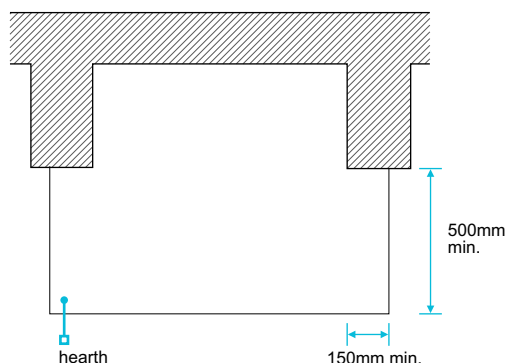
**All – fireplaces and hearths** <sup>6.8.18</sup>

**Fireplaces and hearths shall safely accommodate the appliances for which they are designed.**

Combustible material should not be placed under a constructional hearth unless it is:

- to support the edges of the hearth
- at least 250mm from the material to the top of the hearth, or
- separated from the underside of the hearth by an air space of at least 50mm.

Fireplace recesses should be constructed of solid non-combustible material as follows (dimensions in the diagrams are based on a 125mm concrete hearth below an open fire). The space between a fire back and masonry forming the recess should be filled with vermiculite concrete (1:4, lime:vermiculite with water).



appliance recess with raft lintel:  
suitable for free-standing room heater

fire place recess for inset open fire (without boiler unit)

**All – fireplace surrounds** <sup>6.8.19</sup>

**Fireplace surrounds and their fixings shall be designed, specified and installed to ensure adequate in-service performance and durability.**

The fixing and support should safely accommodate the proposed type of fireplace surround (which could be manufactured in one or a number of pieces), taking into account its size and weight. The walls and floors of the building should safely accommodate the additional load of the proposed fireplace surround.

Fireplace surrounds should be installed by competent operatives, strictly in accordance with the manufacturer's recommendations and fixing specification, and fixed to the structure using mechanical fixings, giving full consideration to:

- the type of material used to manufacture the surround
- the configuration of the surround
- the size and weight of the surround
- the potential for overturning of the surround or parts thereof
- the type of supporting walls and floors, including the structure (e.g. framed or solid structure) and its finish (e.g. wallboard or wet finish)
- the type, material, number and location of fixings.

Fixings should be of durable material and be appropriate for the type of surround and the supporting wall or floor to which the surround is to be fixed. Fixings should generally be of stainless steel to BS EN ISO 3506 'Mechanical properties of corrosion-resistant stainless steel fasteners' and be specified to provide suitable strength and durability. Materials that comply with recognised standards which provide equal or better performance are also acceptable.

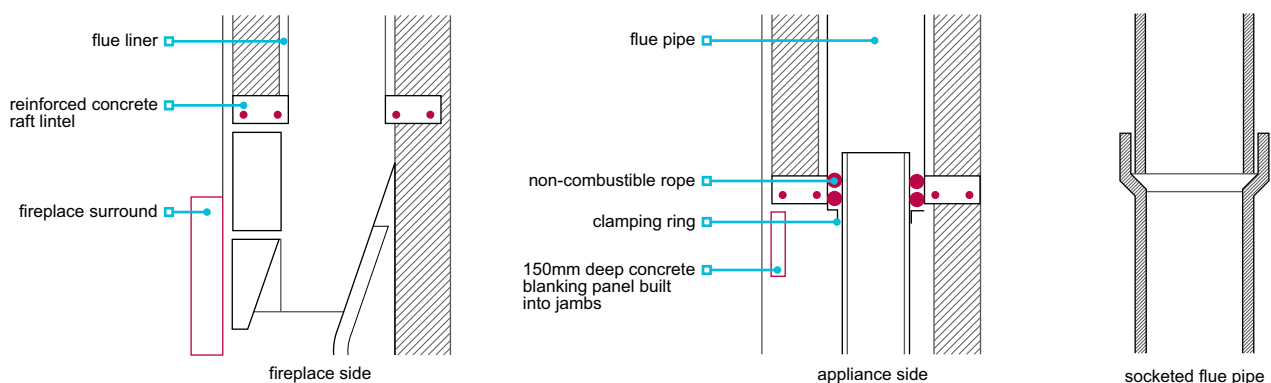
Methods that rely solely on adhesive for fixing fireplace surrounds to the structure are not acceptable.

More information on the installation of all types of natural and artificial stone fireplace surrounds can be found in the Stone Federation Great Britain 'Fireplace Surrounds' data sheet ([www.stonefed.org.uk](http://www.stonefed.org.uk)).

### All – flue pipes <sup>6.8.20</sup>

**Flue pipes and terminals shall be suitable for their purpose and provide unrestricted passage for combustion gases between the fireplace, or appliance, and the outlet.**

The connection between a fireplace, or appliance, and the flue should be correctly constructed.



Where the bottom of the flue is not directly over an appliance, it should be provided with a means of access for cleaning and inspection.

Adjustable flue draught control units are not permitted where gas burning appliances are installed. Where adjustable throat units are specified, they should be fitted in accordance with the manufacturer's instructions.

Flue pipes should be jointed in accordance with the manufacturer's instructions, fixed socket up and correctly aligned.

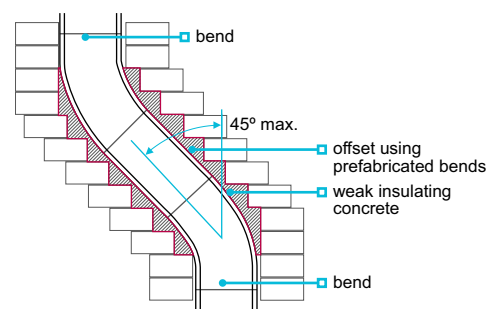
**Table 9:** Acceptable standards for flue pipes

Flue material	Guidance
Flue pipes for gas appliances	BS 715
Cast iron flue pipes	BS 41
Mild steel flue pipes	BS 1449 (minimum 3mm wall thickness)
Stainless steel flue pipes	BS EN 10088 (minimum 1mm thick) and be one of the following grades: 1.4401, 1.4404, 1.4432 or 1.4436
Vitreous enamelled flue pipes	BS 6999, low carbon steel coated internally and externally with acid-resisting enamel

### All – flue liners <sup>6.8.21</sup>

**Flue liners shall be unaffected by flue gases and suitable for their purpose.**

To produce a suitable flue path, appropriate components should be selected to keep cutting and joints to a minimum. At changes in direction, including bends, offsets and tees, purpose-made components should be used.



chimney with flue liner suitable for solid fuel

Flue liners should be:

- clay or purpose-made concrete, as specified in the design
- handled carefully to prevent chipping or cracking
- installed in accordance with the manufacturer's instructions and the design
- sealed at their joint with the starter block or throat unit (no cavity should be formed between the linings and the starter elements)
- placed with the sockets or rebate ends facing up.

Liners suitable for solid fuel appliances, and generally suitable for other fuels, include liners whose performance is at least equal to the designation T450 N2 S D 3, as described in BS EN 1443: 1999, such as:

- clay flue liners with rebates or sockets for jointing meeting the requirements for class A1 N2 or class A1 N1 as described in BS EN 1457
- concrete flue liners meeting the requirements for the classification type A1, type A2, type B1 or type B2 as described in prEN 1857(e18) January 2001, or
- other products that are independently assessed in accordance with Technical Requirement R3.

Alternatively, imperforate clay pipes with sockets for jointing as described in BS 65:1991 are acceptable.

Joints should be made in accordance with the manufacturer's recommendations, generally using:

- fire cement, or
- refractory mortar

Joints should be fully filled, and surplus material cleared from the inside of each joint as the flue is built.

Spaces between the lining and the surrounding masonry should be:

- filled with weak insulating concrete, or
- in accordance with the manufacturer's recommendations, with the specified material providing adequate protection.

Ordinary concrete should not be used to fill the space between the lining and the surrounding masonry.

Suitable mixtures for weak insulating concrete include:

- one part ordinary Portland cement to 20 parts suitable lightweight expanded clay aggregate, minimally wetted
- one part ordinary Portland cement to six parts vermiculite, or
- one part ordinary Portland cement to 10 parts perlite.

### All – flues <sup>6.8.22</sup>

**Flues shall be suitable for their purpose and adequately separated from combustible materials.**

Flues should be:

- suitable for the type and size of appliance which they serve
- constructed in accordance with the design and the manufacturer's recommendations
- tested in accordance with this chapter.

Combustible materials close to any brickwork or blockwork chimney should be:

- 200mm minimum from a flue
- 40mm from the face of the chimney, in Scotland, and
- metal fixings in contact with combustible materials should be a minimum of 50mm from the flue.

This does not apply to a floorboard, skirting, dado or picture rail, mantel shelf or architrave.

Twin wall flue systems should comply with:

- BS 715, or
- be assessed in accordance with Technical Requirement R3.

### All – chimneys <sup>6.8.23</sup>

**Chimneys shall provide fire protective casing for flues, and shall be capable of adequately supporting the flue liner, while resisting damp penetration and the products of combustion. Issues to be taken into account include:**

- a) construction of chimneys
- b) typical construction details
- c) damp penetration and weatherproofing
- d) coring and drying.

#### Construction of chimneys

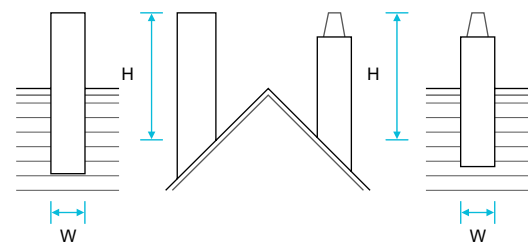
Masonry chimneys should be properly bonded to, or supported by, the adjoining walls of the building.

Foundations to a chimney should:

- be the same depth as adjacent wall foundations
- be designed to avoid uneven settlement

Height (H) of an unrestrained chimney should:

- not exceed 4.5x the smallest dimension on plan of the chimney (W) (where the density of the masonry is a minimum of 1500kg/m<sup>3</sup>), or
- be designed by an engineer in accordance with Technical Requirement R5.



Chimneys which:

- are of block, brick or stone should have a minimum wall thickness of 100mm, excluding the lining thickness
- are built in a cavity separating wall should form two leaves, each a minimum of 100mm, between the flue and adjoining building

- where the chimney forms part of the wall, be a minimum of 100mm wider than the chimney base.

- form part of a compartment wall, and are not back to back with an adjacent chimney, should have a minimum wall thickness of 200mm separating it from the other building or home.

Factory-made insulated chimneys should be assembled, erected, anchored and protected in accordance with the manufacturer's instructions.

Masonry for chimneys:

- below roof level may be constructed using the same bricks and mortar as used for the general brickwork
- constructed with hollow or cellular blocks should be suitable for the construction of chimneys and filled with concrete as the work proceeds

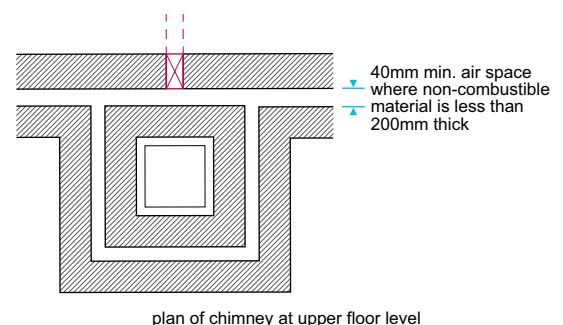
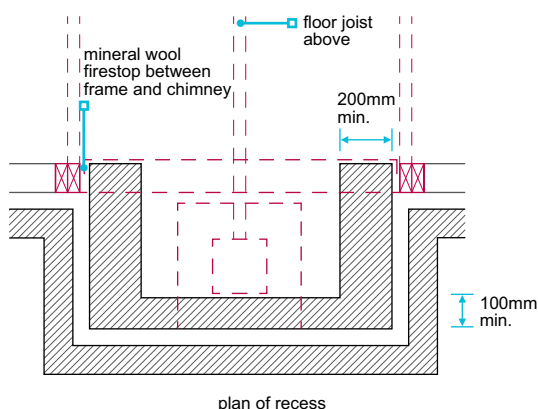
- should be frost resistant above the roof unless protected by a capping projecting by a minimum of 50mm (in Scotland, frost-resistant bricks should be used for all facing brickwork).

Connections between flue blocks and ridge terminals should be made:

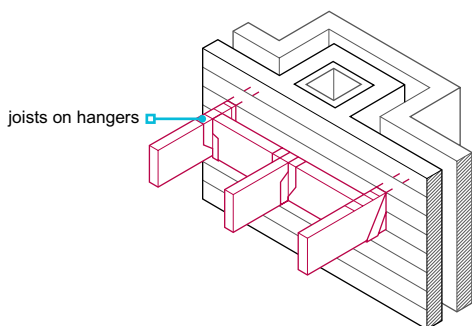
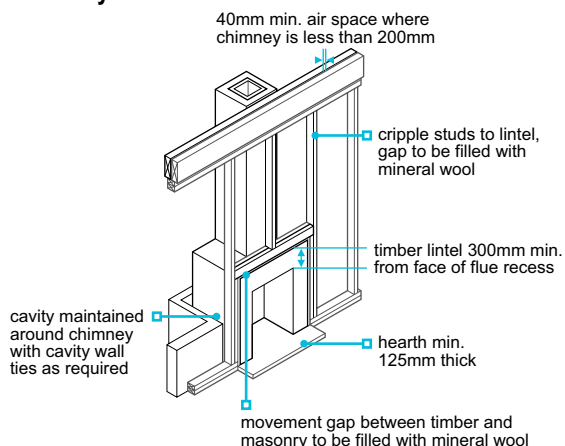
- as detailed in the design
- using the correct fittings and supports as specified by the manufacturers of the flue blocks, flue pipe and ridge terminal.

#### Typical construction details

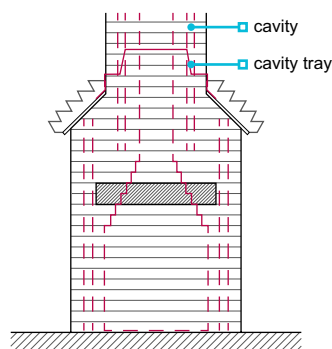
##### External fireplace recess and chimney



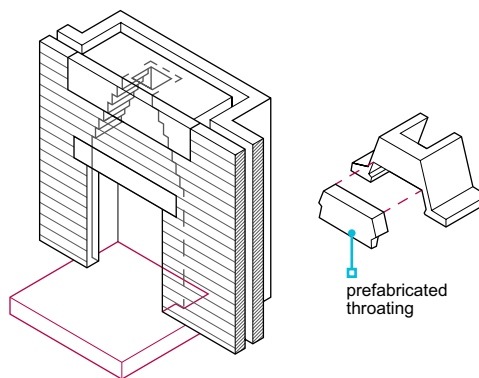
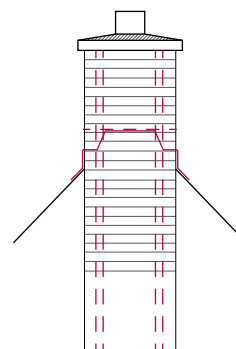
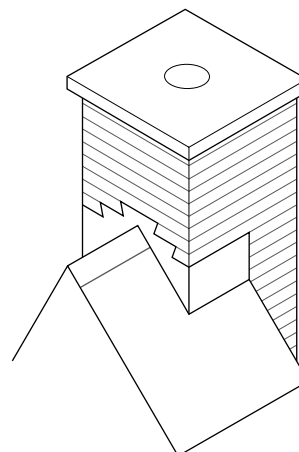
**Timber chimney frame construction**



In Scotland, joists, etc. should be min. 200mm from the inner surface of the flue; brickwork or blockwork in chimney construction should be min. 100mm thick with a min. density of 1 600 kg/m<sup>3</sup>; aircrete blocks should be min. 150mm thick.



**External chimney breast with masonry inner leaf**



Other alternatives may be suitable, provided they meet the appropriate performance standards.

**Damp penetration and weatherproofing**

Where chimneys exit close to the ridge of a pitched roof, occasional damp penetration may occur below roof level. In this situation:

- the roof space should be well ventilated
- any dampness penetrating downwards should not reach the living areas.

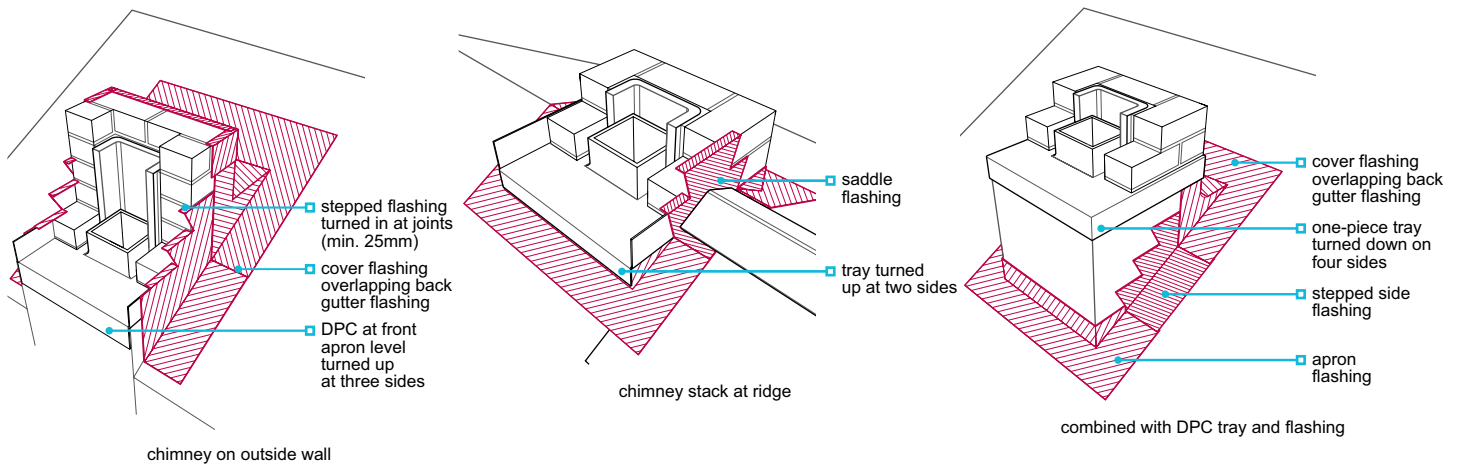
Where chimneys exit close to the eaves of a pitched roof or through a flat roof, trays and flashings should be installed in the chimney so that all damp penetration is prevented.

DPCs, flashings and gutters should be provided at the intersection point of the chimney with the surface of the roof through which the chimney passes. DPCs to the main walls should be carried through the base of chimneys.

Flashings should be made from compatible non-ferrous metal. Lead trays should be bitumen coated where in contact with cement.

In areas of severe and very severe exposure, the following details should be used. In lower exposure zones, the tray upturn may be on the outside of the flue liner. All other details are the same.





### Coring and drying

Where a core (e.g. a sack full of loose straw, or similar) is used to prevent mortar dropping into the flue liner during construction, the builder should ensure that it is removed on completion of the chimney.

A chimney should be allowed to dry naturally for a minimum period of 14 days before use.

### Masonry <sup>6.8.24</sup>

**Masonry shall be capable of supporting intended loads and have appropriate resistance to the adverse effects of frost and sulfates.**

Masonry, including bricks, blocks, stone for masonry and reconstructed stone, should:

- be in accordance with BS 6461 and BS EN 771
- where clay bricks are used in external chimney stacks, be of durability rating F2,S1 (as described in BS EN 771) or protected by a projecting capping
- where blocks are used, have a minimum block density of 1500 kg/m<sup>3</sup> unless designed by an engineer in accordance with Technical Requirement R5.

In Scotland:

- frost-resistant bricks should be used for all external facing brickwork
- where 100mm blocks are used for chimney construction, they should have a minimum density of 1,500 kg/m<sup>3</sup>.

### Mortar <sup>6.8.25</sup>

*Also see: Chapter 6.1*

**Mortar shall be batched and mixed to achieve adequate strength and durability.**

Mortar should be in accordance with Chapter 6.1 'External masonry walls', and include sulfate-resisting cement where flue gases are liable to affect the masonry, e.g. above roof level.

### DPC <sup>6.8.26</sup>

**Materials for damp-proofing shall adequately resist the passage of moisture into the building.**

The following are acceptable for use as DPCs:

- Bitumen to BS 6398.
- Polyethylene to BS 6515 (not to be used in the chimney stack above roof level).
- Proprietary materials assessed in accordance with Technical Requirement R3.

### Flashings <sup>6.8.27</sup>

**Flashings and trays shall be capable of adequately resisting the entry of moisture into the building.**

Suitable materials for flashings and trays include:

- milled sheet lead (minimum code 4) to BS EN 12588
- aluminium and aluminium alloys to BS 1470 (0.6-0.9mm thick)
- zinc alloy complying to BS 6561 and 0.6mm thick.

**Terminals** 6.8.28

Flue terminals shall be suitable for their purpose and assist the functioning of the flue. Issues to be taken into account include:

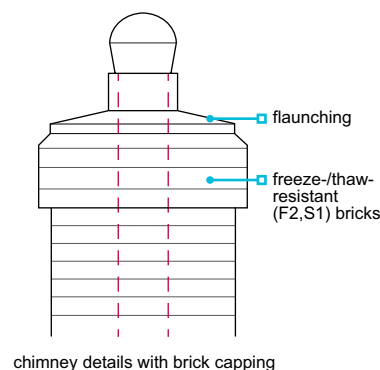
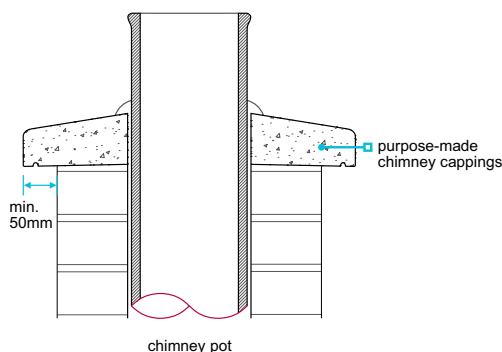
- a) draught improvement
- b) chimney capping.

Relevant standards for flue terminals

<b>BS 1181</b>	Terminals in clay flue pipes
<b>BS EN 1858</b>	Terminals in chimneys serving gas appliances
<b>BS 715</b>	Terminals in flue pipes for gas appliances

Terminals should be:

- purpose-made or formed by extending the flue lining a minimum of 20mm above the head of the chimney
- embedded a minimum of 125mm into the chimney, excluding any flaunching, or 0.25x the length of the terminal, whichever is the greater
- the same cross-sectional area as the flue (solid fuel has a minimum requirement of a 200mm diameter).



The terminal of a masonry flue should be jointed to the flue lining with cement mortar to form a seal.

**Draught improvement**

Where downdraughts may occur, terminals designed to increase updraught should be fitted. However, a terminal will not overcome problems caused by high pressure zones. Where relevant, the Solid Fuel Association or other authoritative body should be consulted.

**Chimney capping**

Where a chimney is to be capped:

- a single unjointed concrete or stone capping should be used
- it should project and be throated to cast water away from the face of the chimney
- the slab should project 50mm beyond the sides of the chimney, and the withes between flues should be carried to the underside of the slab.

Decorative brick cappings should be carefully constructed to avoid rain penetration and frost damage. The use of frost-resistant bricks may be required.

In Scotland, bricks used for facing brickwork should be frost-resistant.

### Flue testing <sup>6.8.29</sup>

#### Installations shall be tested before use.

Flues should be checked during construction to ensure:

- there are no obstructions in the flue
- mortar or other blockages are removed
- when the flue is complete, a visual check should be made and obstructions cleared.

#### Coring ball test for solid fuel appliances

When a visual test cannot be conducted, or is inconclusive, the coring ball test should be conducted as follows:

- A suitable concrete or metal ball should be attached to a strong cord or rope.
- The ball should be slowly lowered from the flue outlet to the bottom of the flue (the fireplace recess or the appliance connection).
- Where a blockage or obstruction is found, it must be removed and the test repeated until the flue is completely clear of obstruction.

#### Smoke test for solid fuel appliances

This test is designed to show that a flue draws adequately and that there are no leaks between the appliance and the terminal. It must be conducted when neither the flue to be tested or adjacent flues are in use. The test should be conducted as follows:

- The flue should be warmed for 10 minutes with a heat source such as a blow lamp. Where an appliance is fitted, all doors, including flue access doors, should be closed.
- Two purpose-made smoke pellets should be placed in the appliance firebox or in the bottom of the flue and ignited, then, closed or sealed off and the smoke allowed to rise.
- When smoke appears at the top of the flue, the outlet should be sealed with a blow-up rubber ball or other airtight closing system.
- The whole structure forming the flue should be inspected externally for smoke leakage. This should include the top of cavity walls and any other possible smoke paths, even those terminating some distance from the flue.
- The test should be continued for a minimum of five minutes.

#### Flues for gas appliances

For gas appliances, more sophisticated flue tests may be required and should be conducted by the appliance installer.

#### Flues for oil appliances

Flues for oil fired appliances should be tested as required by the appliance manufacturer.

### Further information <sup>6.8.30</sup>

- *Approved Document Part J 'Heat producing appliances'*
- *Building Standards (Scotland) Regulations*
- *Building Regulations (Northern Ireland) Technical Booklet L 'Combustion appliances and fuel storage systems'*
- *Institution of Gas Engineers publications: 'Guide for gas installation in timber framed housing' and 'Specification for flues for Class II appliances in timber framed housing'.*

# Curtain walling and cladding

## CHAPTER 6.9

This chapter gives guidance on meeting the Technical Requirements for curtain walling and cladding.

6.9.1	Compliance	03
6.9.2	Provision of information	03
6.9.3	Certification	03
6.9.4	Loads	03
6.9.5	Support and fixings	04
6.9.6	Durability	05
6.9.7	Interfaces	05
6.9.8	Insulation	05
6.9.9	Damp proofing and vapour control	06
6.9.10	Installation, and tolerances	07
6.9.11	Electrical continuity and earth bonding	07
6.9.12	Maintenance	07
6.9.13	Glazing, gaskets and sealants	08
6.9.14	Cavity barriers and firestops	08
6.9.15	Ventilation screens	08
6.9.16	Handling and storage	08
6.9.17	Curtain walling	09
6.9.18	Rainscreen cladding	11
6.9.19	Insulated render and brick slip cladding	12



Raising Standards. Protecting Homeowners

### Introduction

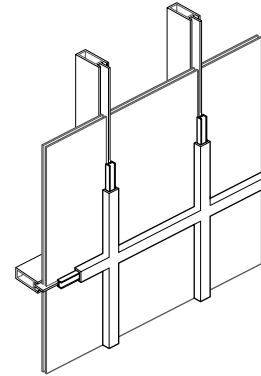
This chapter gives guidance on the forms of curtain walling and cladding acceptable to NHBC. Curtain walling and cladding systems that do not conform to the descriptions in this chapter will not generally be acceptable. Conservatories are not covered by this chapter.

Guidance on the use of other types of cladding, including brickwork, rendered masonry, vertical tile and slate cladding and timber cladding, is given in Chapter 6.1 'External masonry walls' and Chapter 6.2 'External timber framed walls'.

#### Curtain walling

Comprising a prefabricated or site assembled support framework with infill panels and/or wall sections with glazing systems which include:

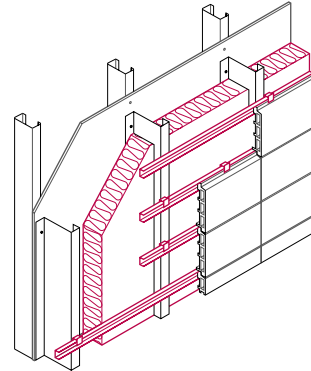
- structural silicone glazing
- mechanically fixed structural glazing
- slope glazing, excluding patent glazing
- coupled door and window frame assemblies (including spandrel panels) which are one storey or more in height, or not contained between a floor and ceiling.



#### Rainscreen cladding

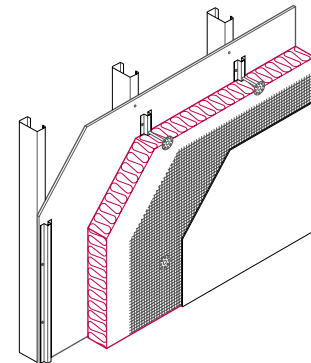
Comprising:

- an outer skin of panels which have unsealed, open, baffled or labyrinth (rebated) joints
- a minimum 50mm pressure equalised air gap between the insulation and the panels
- an insulated and airtight backing wall.



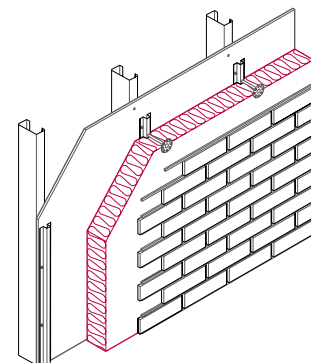
#### Insulated render

Comprising insulated render systems fixed to a backing wall.



#### Brick slip cladding

Comprising brick slip cladding fixed to a backing wall.



#### Stone and precast concrete cladding

Stone and precast units should be designed as curtain walling or rainscreen cladding in accordance with this chapter.

**Definitions for this chapter**

<b>Air barrier</b>	A continuous layer that limits air leakage through the backing wall.
<b>Air cushion</b>	Balancing external and internal air pressure to create a cushion within the air gap.
<b>Air gap</b>	The space between the back of the cladding panels and the external face of the insulation in a rainscreen system.
<b>Backing wall</b>	A framed or masonry wall to which the system is fixed.
<b>Brick slip cladding system</b>	A brick slip system fixed to masonry or framed backing walls, generally supported by a proprietary carrier.
<b>Cavity</b>	The space between the cladding system and the backing wall. The cavity should be adequately drained, and ventilated where required.
<b>Cladding panels</b>	The outer units of a rainscreen cladding system which provide some protection.
<b>Compartmentation</b>	The provision of baffles and cavity closers to form compartments within the air gap of a rainscreen cladding system to equalise pressure.
<b>Curtain walling</b>	A form of enclosure that supports no load other than its own weight and the environmental forces that act upon it, e.g. wind, water and solar.
<b>Curtain walling system</b>	The vertical building enclosure system, including frames, brackets, fixings, flashings, gutters, copings, glass, panels, gaskets and sealant, that forms the assembly.
<b>CWCT</b>	The Centre for Window and Cladding Technology at Bath University.
<b>CWCT Standard</b>	The current Centre for Window and Cladding Technology Standard for systemised building envelopes.
<b>Design life</b>	The period for which materials, products and systems should be designed to be durable, assuming routine inspection and maintenance.
<b>DPC/DPM</b>	Prevents the passage of moisture. In curtain walling terminology, a DPC is often referred to as a DPM.
<b>Façade</b>	The external facing part of the building envelope.
<b>Fire and smoke stopping</b>	Prevention of the transmission of fire and smoke through voids or cavities.
<b>Fixing</b>	Componentry used to attach or secure other components, e.g. curtain walling or a cladding system, to the structure.
<b>Gasket</b>	A compressible material used to form an airtight and/or watertight seal.
<b>In-service performance</b>	The manner or quality of functioning of a material, product or system.
<b>Insulated render system</b>	A cladding system applied externally to an insulating layer which is fixed to a backing wall.
<b>Interstitial condensation</b>	Condensation caused by vapour from within the building condensing on colder surfaces within the wall construction, often occurring due to a cold bridge.
<b>Negative pressure</b>	Where the air pressure on the internal face of the system is greater than that on the external face.
<b>Positive pressure</b>	Where the air pressure on the external face of the system is greater than that on the internal face.
<b>Primary components</b>	Components and parts of the system that are not easily replaceable. These may include: <ul style="list-style-type: none"> <li>■ cladding panels</li> <li>■ fixings</li> <li>■ framing</li> <li>■ insulation</li> <li>■ vapour control layers</li> <li>■ weathering components.</li> </ul>
<b>Pressure equalisation</b>	The creation of an air cushion within the cavity to reduce the amount of water passing through the joints of a rainscreen. Compartmentation and adequately large joints are required to achieve pressure equalisation.
<b>Rainscreen</b>	The part of the assembly, generally the outermost, that prevents the majority of rain from penetrating the wall. Some water may pass through the joints of a rainscreen, but this should be limited by appropriate detailing of open joints or the provision of baffled or labyrinth joints.
<b>Rainscreen cladding system</b>	A façade that provides a barrier to wind and rain and which typically includes a vapour control layer, air barrier, supporting framework and fixings, insulation, breather membrane, cavity/air gap and cladding panels. Traditional tile hanging and timber cladding are not classed as rainscreen cladding systems under the definitions of this chapter.
<b>Replaceable components</b>	Those which are readily replaceable without compromising the design and durability of the building or the need for progressive dismantling of the envelope. Where this cannot be achieved, components should be designed as primary components. A method statement should be provided to demonstrate how components will be replaced with specific reference to accessibility as detailed in this chapter.
<b>Secondary components</b>	Components and parts of the system that are easily replaceable. These may include: <ul style="list-style-type: none"> <li>■ cladding panels</li> <li>■ external finishes</li> <li>■ glazing and gaskets</li> <li>■ internal linings</li> <li>■ seals and sealant</li> <li>■ window and door furniture.</li> </ul>

<b>Separating floors and walls</b>	Floors and walls designed to provide separation between homes.
<b>Slope glazing</b>	A drained and ventilated sloped roofing system.
<b>Systems</b>	For the purposes of this chapter, this term refers to acceptable forms of curtain walling, rainscreen cladding, insulated render systems and brick slip cladding systems.
<b>Spandrel panel</b>	A panel used in place of glazing units to hide the edges of floor slabs, ceiling details, insulation, and other building elements.
<b>Test pressure</b>	The pressure at which testing is conducted.
<b>Vapour control layer</b>	A layer used to restrict the passage of water vapour into the construction to reduce the risk of interstitial condensation.

### Compliance <sup>6.9.1</sup>

*Also see: Chapter 2.1*

#### **Curtain walling and cladding systems shall comply with the Technical Requirements.**

Curtain walling and cladding that comply with the guidance in this chapter will generally be acceptable.

### Provision of information <sup>6.9.2</sup>

#### **Designs and specifications shall be produced in a clearly understandable format, include all relevant information and be distributed to appropriate personnel.**

Clear and fully detailed drawings should be available on site to enable work to be carried out in accordance with the design. Design and specification information should be issued to site supervisors, relevant specialist subcontractors and suppliers, and include the following information:

- A full set of drawings.
- A schedule of revisions.
- Manufacturer's specification.
- Specific details of all interfaces.
- Fixing schedules.
- Manufacturer's recommendations for proprietary items.
- Details of the on-site testing regime.

### Certification <sup>6.9.3</sup>

#### **Curtain walling and cladding systems shall be adequately tested, certified and designed in accordance with appropriate standards.**

Curtain walling and cladding systems should have certification confirming satisfactory assessment, undertaken by an independent technical authority. Where applicable, certification should be in accordance with CWCT Standard for systemised building envelopes (or a suitable alternative acceptable to NHBC). Independent technical approvals authorities acceptable to NHBC include:

- British Board of Agrément (BBA)
- Building Research Establishment (BRE), or
- certification bodies considered by NHBC to be a suitable alternative.

Certification and test documentation should be:

- made available to NHBC before work begins on site
- used as reference to ensure compliance.

The use of the system should be within the scope of the certification and test documentation.

### Loads <sup>6.9.4</sup>

#### **Curtain walling and cladding systems, including brackets and fixings, shall allow movement without causing damage or deformation, and safely transfer loads to the building.**

Dead loads and live loads should:

- be transferred safely to the building's structure without undue permanent deformation or deflection of any component
- be calculated in accordance with BS EN 1991-1-1 and BS EN 1991-1-4, and take account of internal and external pressures, the location, shape and size of the building.

The following should be accommodated without any reduction in performance:

- Thermal-induced loads due to differential stresses caused by temperature gradients within materials or components.
- Stresses in components and materials (these should not exceed the permissible values recommended by the product manufacturer).
- Movement within the curtain walling or cladding.

Causes of movement include:

- dead and live loads
- changes in temperature
- changes in the moisture content of components
- freezing of retained moisture
- creep.

Allowance for movement should be provided in accordance with the design.

### Support and fixings <sup>6.9.5</sup>

**Curtain walling and cladding systems shall be securely fixed with suitably durable fixings to ensure adequate in-service performance.**

The cladding system and associated fixings should be correctly located and securely fixed in accordance with the design and the manufacturer's recommendations. Fixings and supports, including the type, size and positioning of anchors, fixing rails, frames, fixings, fasteners and bracketry, should be in accordance with the design, and:

- accommodate specified loads
- account for packing of brackets to achieve surface tolerance, in accordance with the manufacturer's recommendations
- be accurately set out
- generally be stainless steel, suitable non-ferrous metal or appropriate plastics
- be installed ensuring dissimilar metals are separated to avoid bimetallic corrosion
- be installed ensuring aluminium components are separated from direct contact with cementitious surfaces.

Mechanically fixed systems should be in accordance with the manufacturer's recommendations, and fixings should:

- have the correct embedding, spacing and edge distances
- be installed to the correct torque settings
- have suitable locking nuts and washers.

Fixings should be manufactured from:

- phosphor bronze
- silicon bronze
- BS EN ISO 3506 stainless steel
- mild steel with coatings to BS EN 12329, BS EN 12330, BS EN 1461, or other appropriate treatment in accordance with BS EN ISO 12944 or BS EN ISO 14713
- BS EN 573 and BS EN 755 aluminium alloy
- appropriate plastics
- materials assessed in accordance with Technical Requirement R3.

Materials that comply with recognised standards and which provide equal or better performance to those above will generally be acceptable to NHBC.

Pull-out or destructive testing of anchors and fixings should:

- comply with BS 5080
- comply with the Construction Fixings Association Guidance Note 'Procedure for Site Testing Construction Fixings'
- be carried out in accordance with the design
- carried out at a frequency agreed with NHBC.

The test report should be made available to NHBC.

Adhesive-fixed systems should be installed to a suitably prepared backing wall, providing:

- an assessment of the backing wall is available to confirm suitability
- it is used in accordance with the design.

Adhesive fixing of rails, frames, fixings and fasteners should:

- only be specified where there is no suitable alternative
- be used in accordance with the manufacturer's recommendations.

Timber should only be used where it is:

- easily inspected and replaced without disturbing the curtain walling system
- treated in accordance with Chapter 3.3 'Timber preservation (natural solid timber)'.



### Durability <sup>6.9.6</sup>

*Also see: Chapter 3.3*

**Curtain walling and cladding systems shall provide satisfactory durability (subject to routine inspection and maintenance). Timber shall be either naturally durable or preservative treated to provide adequate protection against rot and insect attack.**

The system should be designed to avoid the need for disproportionate work when repairing or replacing individual components. In addition:

- primary components should provide satisfactory in-service performance for the design life of the building
- secondary components should provide satisfactory in-service performance for a minimum of 25 years.

The curtain walling system should be constructed with corrosion resistant or adequately protected materials. The risk of bimetallic corrosion should be avoided by the isolation of dissimilar metals.

Systems should not include materials liable to infestation by micro-organisms, fungi, insects or vermin.

### Interfaces <sup>6.9.7</sup>

**Curtain walling and cladding systems shall have suitable interfaces and resist the penetration of water and wind.**

The design should indicate the contractor responsible for constructing interfaces.

Interfaces, including those between curtain walling and cladding systems, and those between curtain walling and cladding systems and other elements of the building (e.g. walls, roof, doors and windows), should be carefully designed and detailed to be weather resistant, and prevent moisture reaching parts of the wall that it could adversely affect.

The design should take account of:

- differing profile characteristics
- movement
- continuity of insulation, vapour barriers and breather membranes
- tolerances and deviation
- the erection sequence
- planned maintenance.

### Insulation <sup>6.9.8</sup>

**Insulation shall be suitable for the intended use.**

Insulation should be:

- in accordance with the design and the manufacturer's recommendations
- installed correctly to minimise the risk of thermal bridging, surface and interstitial condensation
- securely fixed to the support frame or backing wall with appropriate fixings and/or adhesive in accordance with the manufacturer's recommendations
- returned into window and door openings, and continuous around penetrations through the wall
- neatly cut around fixings and brackets.

Insulation materials should:

- be inert, durable, rot and vermin proof
- not be adversely affected by moisture
- be one of the materials listed in Table 1.

**Table 1:** Materials for insulation

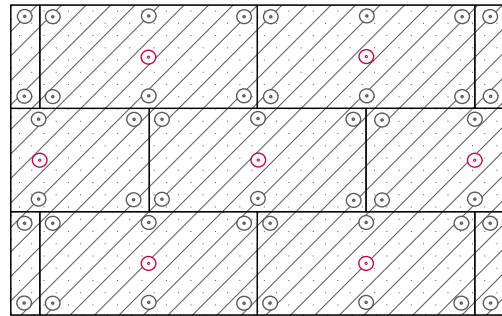
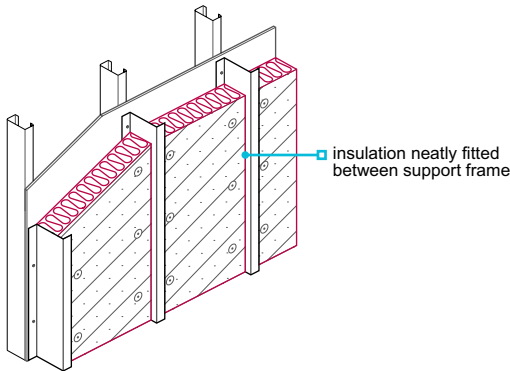
Insulation type	Relevant standard
Mineral wool	BS EN 13162
FR grade (flame retardant) expanded polystyrene	BS EN 13163
FR grade (flame retardant) extruded polystyrene	BS EN 13164
Rigid polyurethane foam and polyisocyanurate	BS EN 13165
Phenolic foam	BS EN 13166
Cellular glass	BS EN 13167
Other materials	Technical Requirement R3

Reference should be made to BRE document BR135 – 2003 'Fire performance of external thermal insulation for walls of multi-storey buildings' when specifying the type of insulation system to be installed.

**Rainscreen cladding**

The backing wall should be adequately insulated, particularly at exposed areas. Where open joints are used, a continuous and durable breather membrane should be provided over the outer face of the insulation.

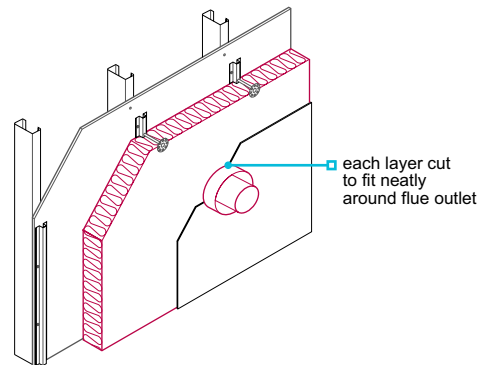
Where the insulation is fixed to the backing wall, a minimum of one non-combustible fixing per 1m<sup>2</sup> or per insulation batt, whichever is the lesser, should be provided in addition to the other fixings.



**Insulated render**

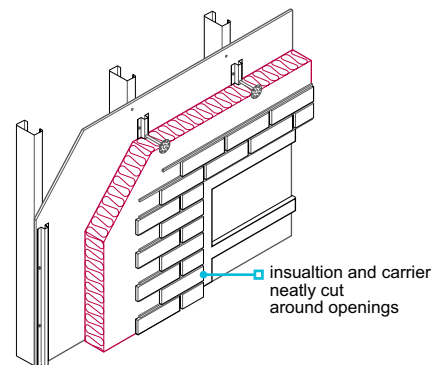
A minimum of one non-combustible fixing per 1m<sup>2</sup> or per insulation batt, whichever provides the greater number, should be provided in addition to the other fixings. Non-combustible fixings should be fixed through the mesh reinforcement.

Insulation should be suitable to receive the render finish, and keyed where appropriate.



**Brick slip cladding**

Where the insulation is fixed to the backing wall, a minimum of one non-combustible fixing per 1m<sup>2</sup> or per insulation batt, whichever is the lesser, should be provided in addition to the other fixings.



**Damp proofing and vapour control <sup>6.9.9</sup>**

**Curtain walling and cladding systems, including damp proofing materials and breather membranes, shall adequately resist the passage of water into the building and allow water vapour to pass outwards.**

Damp proofing should:

- be installed correctly to provide a physical barrier to the passage of water, and to ensure water is directed to the outside
- include cavity trays with stop ends at the base of the system, above openings, above cavity barriers, interfaces and other interruptions to the cavity where necessary
- use DPCs/DPMs where necessary, including the junction between the system and any other component or systems
- use only appropriate tapes and sealant (but not solely rely on sealant) in accordance with the design and the manufacturer's recommendations.

For curtain walling systems, the DPC/DPM should extend the full height of the system and have appropriate details at each interface (including floors, walls, roofs, balconies and terraces).

### DPCs/DPMs and flexible cavity trays

Damp proofing should be:

- formed from materials which are compatible with adjoining components
- the correct dimensions to suit the detailed design
- constructed from preformed components at complicated junctions.

The following materials are acceptable for use as DPCs/DPMs:

- BS 6515 polyethylene.
- EPDM.
- Neoprene.
- Materials assessed in accordance with Technical Requirement R3.

### Flashings

The following materials are acceptable as flashings:

- BS EN 12588 rolled lead sheet (minimum Code 4).
- BS EN 485 and BS EN 573 aluminium and aluminium alloys.
- BS EN 988 zinc alloys.
- Stainless steel.

### Breather membranes

Breather membranes should:

- comply with BS 4016 (Type 1 in areas of very severe exposure), or
- be in accordance with Technical Requirement R3.

## Installation and tolerances <sup>6.9.10</sup>

*Also see: Chapter 9.1*

### Curtain walling and cladding systems shall:

- a) be installed by competent operatives
- b) be installed to achieve design tolerances and established standards.

#### Installation

Systems should be installed by operatives who:

- are competent
- are familiar with the system being installed
- hold a certificate confirming that they have been trained by the system manufacturer, supplier or installer.

#### Tolerances

Systems should be completed, within reasonable tolerances, in accordance with the design, and allowing for the line, level, plumb and plane of the completed wall to be within reasonable tolerances for the materials involved.

## Electrical continuity and earth bonding <sup>6.9.11</sup>

### Curtain walling and cladding systems shall ensure electrical continuity and earth bonding.

Curtain walling and rainscreen cladding should comply with:

<b>BS 7671</b>	'IET Wiring Regulations Requirements for Electrical Installations', formerly 'IEE Wiring Regulations'.
<b>BS EN 62305</b>	'Protection against lightning. General principles'.
<b>BS EN 62305-3</b>	'Physical damage to structures and life hazard'.

## Maintenance <sup>6.9.12</sup>

### Curtain walling and cladding systems shall have appropriate access arrangements for the purposes of cleaning, inspection, maintenance and repair.

Provision should be made for safe future access to the façade. Access should generally be provided from a safe working platform, such as a cradle or mobile elevating platform.

Appropriate arrangements should be made for the replacement of failed insulating glass units without incurring excessive costs for gaining access.

**Glazing, gaskets and sealants** 6.9.13

**Glazing shall be carried out in accordance with relevant standards. Materials used for glazing, gaskets and sealants shall provide satisfactory performance.**

Glazing, including insulating glass units, should be in accordance with Chapter 6.7 'Doors, windows and glazing'. Extruded rubber gaskets should comply with BS 4255 or assessed in accordance with Technical Requirement R3.

Sealant and tapes should be selected and applied in accordance with:

- BS 6213
- BS EN ISO 11600.

Sealant used in locations where differential movement may be expected, e.g. interfaces between the façade and the structure, should be one of the following:

- One or two part polysulphide.
- One or two part polyurethane.
- One part silicone.
- Materials assessed in accordance with Technical Requirement R3.

**Cavity barriers and firestops** 6.9.14

**Materials used for cavity barriers and firestops shall be capable of producing adequate resistance to fire and smoke.**

Materials are acceptable where they are:

- specified in building regulations
- assessed in accordance with Technical Requirement R3.

Systems incorporating proprietary intumescent materials should follow the guidance provided by:

- the Intumescent Fire Seals Association (IFSA)
- the Association for Specialist Fire Protection (ASFP).

**Ventilation screens** 6.9.15

**Ventilation openings shall be protected from the entry of birds and animals.**

Where openings are larger than 10mm, a screen to prevent birds and animals entering the cavity should be provided:

- in accordance with the design
- at penetrations through the cladding.
- at the top and bottom of the rainscreen

**Handling and storage** 6.9.16

**Materials, products and systems shall be protected and stored in a satisfactory manner to prevent damage, distortion, uneven weathering and degradation.**

The handling and storage of curtain walling or cladding system should ensure:

- components are transported, lifted, handled and stored in accordance with the manufacturer's recommendations
- insulated glass units are carefully stored and protected in a sheltered dry area.

Practical steps should be taken to avoid the risk of damage to the curtain walling or cladding system during construction.

### Curtain walling <sup>6.9.17</sup>

Curtain walling shall ensure adequate in-service performance. Issues to be taken into account include:

- acoustic performance
- weather resistance
- thermal bridging condensation
- air infiltration
- opening doors and lights
- off-site testing
- site testing.

#### Acoustic performance

Noise from the curtain walling system caused by loads, movements and changes in the environmental conditions should be accommodated without being intrusive.

The curtain walling system should be designed to resist the passage of airborne and impact sound within the building. To reduce flanking transmission, precautions may be required at the:

- edges of separating floors
- outer ends of separating walls
- outer ends of partition walls
- junctions with roof constructions and parapets.

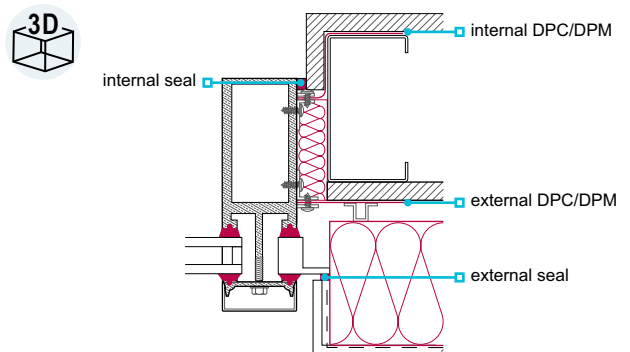
#### Weather resistance

Curtain walling systems should have:

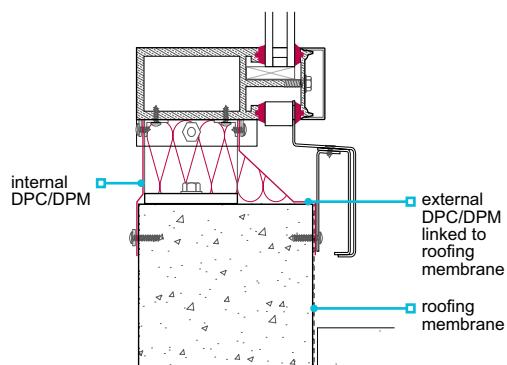
- external and internal air and water seals with a drained and ventilated cavity at each interface
- drained and ventilated glazing rebates including gaskets and seals.

The following illustrations show typical interfaces and general design principles:

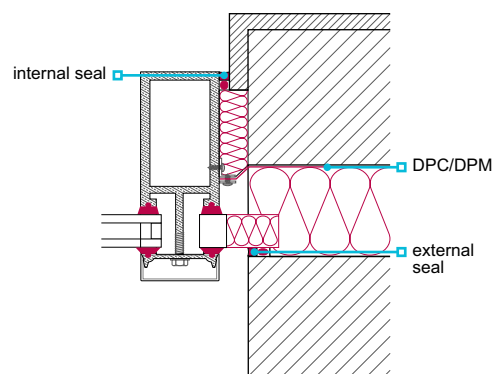
**Figure 1:** Curtain walling to insulated render system: horizontal section



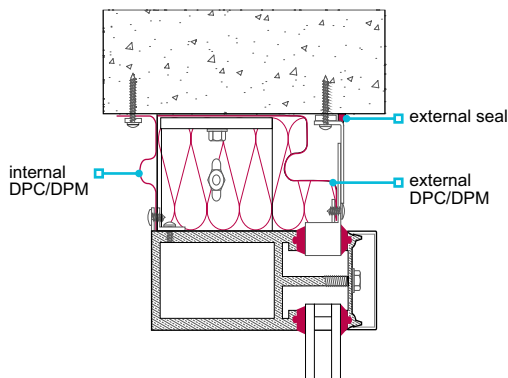
**Figure 2:** Curtain walling to balcony/terrace: vertical section



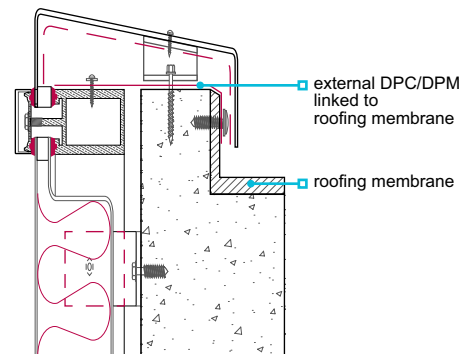
**Figure 3:** Curtain walling to conventional brick and block wall: horizontal section



**Figure 4:** Curtain walling to soffit: vertical section



**Figure 5:** Curtain walling to roof, including coping detail: vertical section



### Thermal bridging and condensation

The design and construction of curtain walls should:

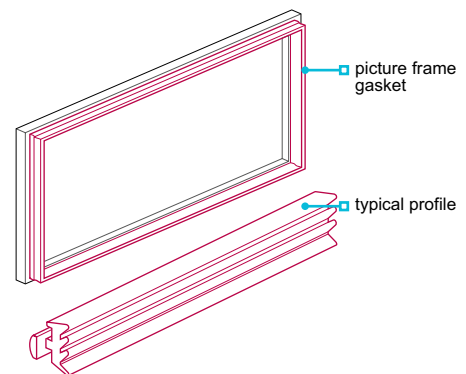
- ensure interfaces are adequately insulated and installed in accordance with the design
- minimise the risk of surface and interstitial condensation by providing thermal breaks and a continuous and durable vapour control layer in accordance with the design
- ensure thermal bridging is controlled so that no part of the curtain wall is more at risk from surface condensation than the glazing.

### Air infiltration

Curtain walling systems should be sealed with preformed factory-moulded 'picture frame' type vulcanised EPDM or silicone internal gaskets. Gaskets and sealants should:

- be used to resist the flow of air from the outside to the interior surface of the curtain walling system
- comply with BS 6213 and be used in accordance with manufacturer's recommendations.

Particular attention should be given to the interfaces between the curtain walling system and the walls, roof, doors, windows and cladding system.



### Opening doors and lights

Opening doors and lights should:

- hang square within the curtain wall frame
- fit neatly and with minimal gaps to ensure effective weatherproofing.

### Off-site testing

Air and water testing of the 'prototype' curtain walling system should be carried out in accordance with, and pass, the CWCT Standard (test sequence A or B), when tested at a test pressure of 600 pascals. Panels tested should be of a similar size and configuration to those to be used on the building.

Where the maximum calculated design wind pressure is above 2400 pascals, the test pressure should be increased to 0.25 x the design wind pressure.

The 'prototype' should remain watertight during and after the test.

At a test pressure of 600 pascals, an air infiltration rate no higher than 1.5m<sup>3</sup>/hr/m<sup>2</sup> for fixed glazed panels is permissible, provided there is no evidence of concentrated leakage.

Wind resistance, serviceability and safety testing should be carried out in accordance with the CWCT Standard.

### Site testing

Site testing should:

- be conducted to determine resistance to water penetration, including joints and interfaces which are intended to be permanently closed and watertight
- ensure a representative sample of the finished installation is hose tested in accordance with the current CWCT Standard for curtain walling
- ensure a minimum of 5% of the completed curtain walling system is tested, especially in vulnerable areas such as joints and interfaces.

Other testing may be acceptable where it is considered to be a suitable alternative by NHBC.

The results of the test should be made available to NHBC.

### Rainscreen cladding <sup>6.9.18</sup>

**Rainscreen cladding systems shall ensure adequate in-service performance. Issues to be taken into account include:**

- a) acoustic performance
- b) weather resistance
- c) thermal bridging and condensation
- d) air infiltration
- e) compartmentation
- f) certification
- g) site testing.

#### Acoustic performance

Noise from the rainscreen cladding system caused by rain striking the outer surface of panels should be accommodated without being intrusive through the use of material that is:

- noise absorbing, or
- anti-drumming.

#### Weather resistance

To ensure moisture is directed to the outside, DPC/DPM arrangements should be correctly formed with suitable upstands and stop ends, including at the junction between the rainscreen cladding and any other component or system. External and internal air and water seals and a drained cavity should be provided at all interfaces.

The air gap between the face of the insulation and the back of the panels should be of sufficient width and have suitably sized drainage, allowing any water passing the joints to:

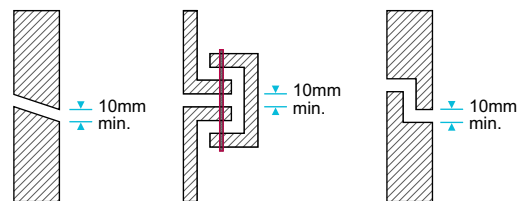
- run down the back of the rainscreen panels
- be discharged externally without wetting the insulation or the backing wall.

#### Free drainage

Air gaps should be adequately ventilated and the following minimum widths maintained behind all rainscreen panels:

- 50mm for panels with open joints, or
- 38mm for panels with baffled or labyrinth (rebated) joints.

Open, baffled or labyrinth (rebated) joints should have a minimum 10mm opening, unless specified otherwise.



#### Thermal bridging and condensation

The system should:

- be designed to minimise the risk of thermal bridging, surface and interstitial condensation
- be assessed using a BS 5250 condensation risk analysis
- generally include a vapour control layer fixed to the warm side of the wall insulation.

### Air infiltration

Before installation of the system, the backing wall should be reasonably airtight with:

- masonry walls jointed to a high standard, i.e. each joint filled
- framed walls, including a rigid sheathing on the cavity face, with each joint taped or sealed.

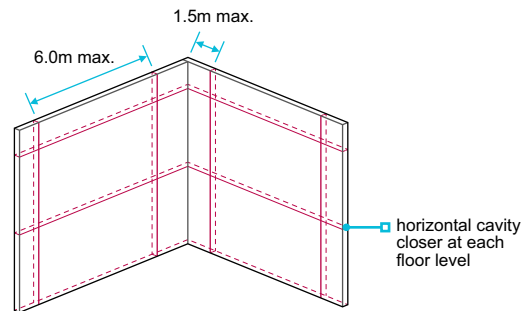
Where reasonable airtightness cannot be achieved:

- a separate continuous vapour permeable air barrier should be provided on the outer face of the backing wall
- joints should be taped or sealed.

### Compartmentation

Rainscreen cladding systems that have open joints between the panels should be designed to be pressure equalised. The cavity should be compartmented by:

- a horizontal cavity closer at each floor level
- vertical cavity closers at centres not exceeding 6m
- vertical cavity closers at centres not exceeding 1.5m within 6m of an internal or external corner
- a vertical cavity closer as close as possible to an external corner, generally within 300mm.



The NHBC Standard for compartmentation is in addition to building regulations (to control the spread of smoke and fire), but may be used for the same purpose.

Cavity closers should:

- be rigid and installed in accordance with the manufacturer's recommendations
- enable ventilation and drainage to be maintained in accordance with the design.

### Certification

Rainscreen cladding systems, including panels, should have current certification confirming satisfactory assessment by an appropriate independent technical approvals authority accepted by NHBC.

### Site testing

On-site hose or sparge bar testing should be carried out with emphasis on interfaces that are designed to be permanently closed and watertight.

The building should remain watertight during and after the test.

## Insulated render and brick slip cladding <sup>6.9.19</sup>

*Also see: Chapter 6.2*

**Insulated render and brick slip cladding shall be designed and installed to ensure adequate in-service performance. Issues to be taken into account include:**

- a) weather resistance
- b) thermal bridging and condensation
- c) air infiltration
- d) insulated render: reinforcement and render
- e) brick slip cladding: slips, carriers and joints.

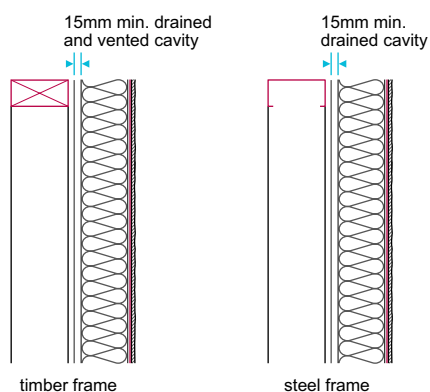


### Weather resistance

Timber and steel framed backing walls should have a cavity between the wall and the insulation which is:

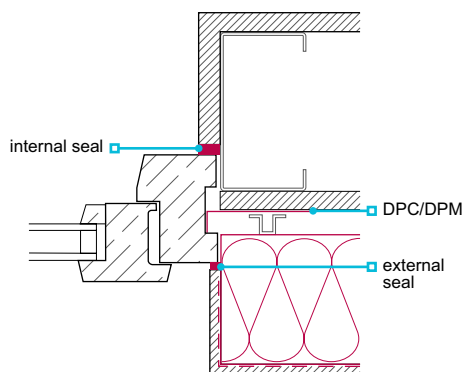
- a minimum of 15mm wide
- drained and ventilated (for timber frame)
- drained (for steel frame).

A cavity can increase the risk of damage from impact, especially at low level, around balconies and where cradle systems etc. can come into contact with the façade. Suitable precautions to resist impact damage should be provided e.g. by the provision of a rigid board behind the insulation whilst maintaining the cavity.

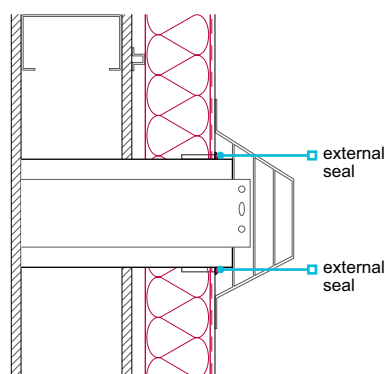


The following illustrations show typical interfaces and general design principles:

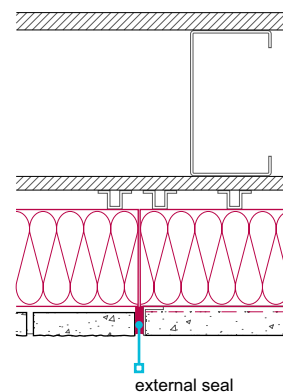
**Figure 6:** Insulated render system to windows and doors: horizontal section



**Figure 7:** Penetration of gas flue through insulated render system on light gauge steel frame: horizontal section



**Figure 8:** Brick slip cladding to insulated render system: horizontal section



Movement joints in the backing wall should be:

- continued through the insulated render system
- formed in accordance with the manufacturer's recommendations.

### Thermal bridging and condensation

The system should:

- be designed to minimise the risk of thermal bridging, surface and interstitial condensation
- be assessed using a suitable condensation risk analysis
- generally include a vapour control layer, fixed to the warm side of the wall insulation.

### Air infiltration

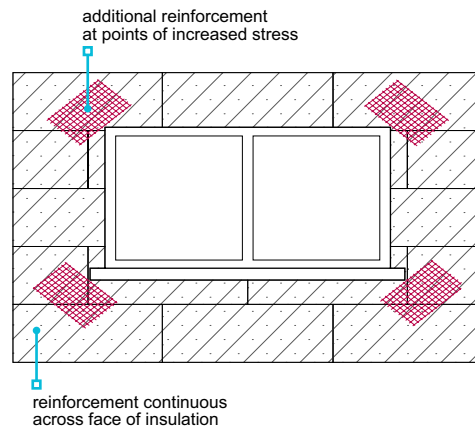
Before installation of the system, the backing wall should be reasonably airtight with:

- masonry walls jointed to a high standard, i.e. each joint filled
- each joint taped or sealed on framed walls, including a rigid sheathing on the cavity face.

**Insulated render: reinforcement and render**

Reinforcement should:

- be detailed in the design and be in accordance with the manufacturer’s recommendations
- be formed with appropriate trim at openings, corners, angles, interfaces and movement joints
- include additional mesh where there may be increased stress in the render system, i.e. at the corners of window or door openings
- be lapped to a minimum of 100mm.



Render should:

- not be applied where the surface has contamination, dust or loose particles
- have the appropriate number and thickness of coats in accordance with the manufacturer’s recommendations

- be mixed to ensure colour consistency where coloured pigments are specified
- be specified and used with the appropriate trims to form corners, returns and features in accordance with the manufacturer’s recommendations.

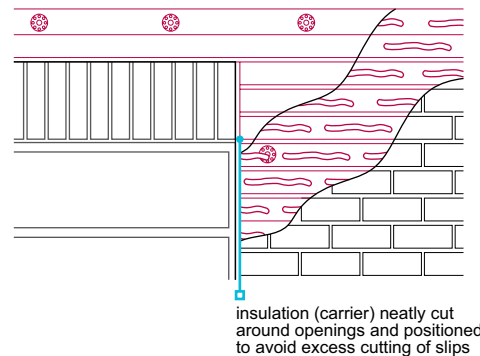
**Brick slip cladding: slips, carriers and joints**

Brick slip systems, including proprietary carriers forming an integral part of the system, should:

- be specified and fixed in accordance with the design and the manufacturer’s recommendations, taking account of relevant height restrictions
- be set out and designed to ensure that excessive cutting of brick slips is avoided, i.e. in the storey heights, at corners and around openings
- have coursing arranged to suit lintel heights.

Mortars, proprietary mortars and grouts should be specified:

- to enable each joint to be adequately filled and appropriately struck
- in accordance with the system manufacturer’s recommendations.



# Light steel framed walls and floors

## CHAPTER 6.10

This chapter gives guidance on meeting the Technical Requirements for light steel framed walls and floors and:

- applies specifically to 'warm frame' construction using 0.45-3.2mm thick framing
- does not apply to light steel framed walls used in basements.

6.10.1	Compliance	01
6.10.2	Provision of information	01
6.10.3	Certification	01
6.10.4	Load-bearing walls and floors	02
6.10.5	Control of fire	04
6.10.6	Acoustic performance	05
6.10.7	Steel and fixings	05
6.10.8	Detailing of steel joists	06
6.10.9	Restraint	08
6.10.10	Fixing floor decking and ceilings	08
6.10.11	Moisture control	08
6.10.12	Insulation	09
6.10.13	Vapour control layers	10
6.10.14	Breather membranes	10
6.10.15	Construction of load-bearing walls and external infill walls	10
6.10.16	Construction of non load-bearing walls	11
6.10.17	Panels, cladding and boards	12
6.10.18	Wall tiles	13
6.10.19	Services	13
6.10.20	Further information	13



Raising Standards. Protecting Homeowners

### Compliance <sup>6.10.1</sup>

Also see: Chapter 2.1

#### Light steel framed walls and floors shall comply with the Technical Requirements.

Light steel framed walls (including external and internal walls) and floors that comply with the guidance in this chapter will generally be acceptable.

For the purpose of this chapter, non load-bearing walls are those not designed to carry the principal dead and imposed loads or provide the overall stability for the building. In some circumstances (e.g. external infill walls), they will carry wind loads.

Construction should be 'warm frame' with sufficient insulation outside the steel envelope to ensure that condensation does not occur within the depth of the light steel members.

Where light steel framing is not of a type shown in this chapter, it should be assessed in accordance with Technical Requirement R3.

### Provision of information <sup>6.10.2</sup>

#### Designs and specifications shall be produced in a clearly understandable format, include all relevant information and be distributed to all appropriate personnel.

Clear and fully detailed drawings should be available on site to enable work to be carried out in accordance with the design. Designs and specifications should be issued to site supervisors, relevant specialist subcontractors and suppliers, and include:

- Relevant drawings and material specification.
- Fixing schedules and details of each connection that is to be made on site.
- Manufacturer's recommendations relating to proprietary items.
- Details of how wall panels are to be fixed to the substructure, adjacent panels and floor and roof framing.
- The number and spacing of bolts, screws and rivets.
- The size and type of each fixing, including corrosion protection.

### Certification <sup>6.10.3</sup>

Also see: [technical@nhbc.co.uk](mailto:technical@nhbc.co.uk)

#### Design of the superstructure shall be checked by an NHBC steel frame certifier.

Homes with load-bearing light steel framed walls or floors require two-stage certification confirming that both the system and the project have been checked. The project-specific design check should be undertaken by an NHBC approved steel frame certifier.

##### Stage 1 – system certification

NHBC requires manufacturers of steel frame systems, which form load-bearing walls or floor panels, to submit a system manual to the Steel Construction Institute (SCI) for assessment.

The manufacturer is the company which assembles the steel frame sections to form the wall and/or floor panels. If in doubt, consult NHBC Standards and Technical.

The manual should contain the information described in Table 1 (though SCI may ask for additional information).

**Table 1:** Items considered in the system manual

Topic	Description
Description of system	<ul style="list-style-type: none"> <li>■ Key features</li> </ul>
Application	<ul style="list-style-type: none"> <li>■ Usage, e.g. maximum number of storeys and type of cladding</li> </ul>
Durability	<ul style="list-style-type: none"> <li>■ Confirmation that minimum design life is 60 years</li> <li>■ Grade of steel</li> <li>■ Corrosion protection</li> <li>■ Supplementary protection</li> </ul>
Strength and stability	<ul style="list-style-type: none"> <li>■ Structural design philosophy (including codes of practice referenced and test reports)</li> <li>■ Grade of steel (traceability)</li> <li>■ Section properties</li> <li>■ Loading</li> <li>■ Ultimate limit state</li> <li>■ Serviceability limit state</li> <li>■ Resistance to overturning</li> <li>■ Racking resistance</li> <li>■ Holding down</li> <li>■ Connections</li> <li>■ Structural integrity</li> <li>■ Positions and sizes of holes through members</li> </ul>

**Table 1 (continued):** Items considered in the system manual

Topic	Description
Claddings	<ul style="list-style-type: none"> <li>■ Acceptable claddings</li> <li>■ Provision of cavity</li> <li>■ Type of wall ties</li> </ul>
Behaviour in relation to fire	<ul style="list-style-type: none"> <li>■ Necessary internal linings</li> <li>■ Fire stops and cavity barriers</li> </ul>
Condensation risk	<ul style="list-style-type: none"> <li>■ Type, thickness and location of insulation material</li> </ul>
Sound insulation	<ul style="list-style-type: none"> <li>■ Confirmation that the specification complies with building regulations/Robust Details</li> </ul>
Balconies, terraces and parapets	<ul style="list-style-type: none"> <li>■ Specific design considerations</li> </ul>
Other	<ul style="list-style-type: none"> <li>■ Other information of relevance to the designer and steel frame certifier</li> </ul>

Where there are choices (e.g. types of claddings), the manufacturer will need to specify which options the SCI is to consider in its assessment. Upon satisfactory completion, SCI will approve the manufacturer’s system manual and issue a numbered ‘system certificate’ which includes:

- a detailed description of the system
- details of usage limitations
- information for reference by the designer and steel frame project certifier.

**Stage 2 – project certification**

NHBC requires the builder to appoint a steel frame certifier to check the design for the home and the site.

The steel frame certifier should:

- check supporting details and calculations
- ensure that the proposals are in accordance with the manufacturer’s system certificate (issued by SCI) this chapter
- provide confirmation that the requirements have been satisfied for each project
- issue a ‘project certificate’ to the builder.

The certificate should be available on site for inspection by NHBC.

Project certificates can only be issued by steel frame certifiers who have been approved by NHBC. Applications to become a steel frame certifier should be made to NHBC.

**Load-bearing walls and floors** <sup>6.10.4</sup>

**Walls and floors shall be designed to support and transfer loads safely and without undue movement.**

**Issues to be taken into account include:**

- a) structural walls
- b) resistance to racking forces
- c) structural floors.

**Structural walls**

The structural design of the building should ensure adequate resistance to loadings including dead loads, imposed loads, wind loads and snow loads, in accordance with:

- BS EN 1991-1-1
- BS EN 1991-1-3
- BS EN 1991-1-4.

Individual studs should generally:

- be a minimum of 36mm wide
- have a maximum spacing of 600mm.

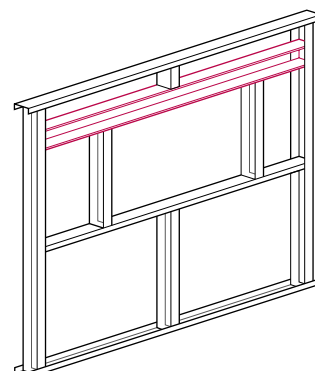
Alternative stud arrangements should be agreed with NHBC.

Lintels should be:

- provided to any opening in load-bearing panels where one or more studs is cut or displaced to form the opening, but are not required where an opening falls between studs
- securely fixed to supporting studs to ensure that loads are fully transferred.

At openings, additional studs may be required to provide support or fixing points for cladding, and wall linings.

Multiple studs should be included to support multiple joists, unless otherwise specified by the designer.



Where panels are diagonally braced with a flat strip, the brace should be fixed to each stud at the intersection to minimise bowing in the bracing member.

Account should be taken of uplift forces, and proper holding-down devices should be provided to resist uplift where necessary. The anchorage for holding-down devices should have sufficient mass to resist the uplift forces (See Clause 6.10.15).

Timber wall plates should be:

- fixed to the head rail of wall panels onto which timber roof trusses bear
- sized (including the head rail), to permit single timber trusses to be positioned at any point between studs.

Movement joints should:

- prevent load transfer onto a chimney or flue (a joint should be constructed between the frame and any chimney or flue)
- not be bridged by non load-bearing walls.

### Resistance to racking forces

Methods to resist racking forces should comply with:

- design to BS EN 1993-1-1, or
- be tested to BS EN 594.

Plywood sheathing should:

- have performance characteristics determined in accordance with BS EN 13986 Table 7
- be at least 5.5mm thick
- be suitable for use in humid conditions to BS EN 636
- be appropriate to the exposure of the building.

Cement bonded particle board sheathing should be in accordance with BS EN 634 and BS EN 13986.

Oriented strand board should be OSB3 to BS EN 300 and have a minimum thickness of 8mm. Proprietary sheathing materials should be in accordance with Technical Requirement R3.

Wall panels may provide resistance to racking forces using one or more of the following techniques:

- internal bracing
- external lining board
- crossed flat bracing
- rigid frame action.
- internal sheathing board

### Structural floors

Floors should:

- be designed to resist loading in accordance with BS EN 1991-1-1
- have a maximum joist spacing of 600mm centres
- have suitably sized trimmers around floor openings.

Light steel joists should be fixed to supporting walls by either:

- web cleats
- bearing onto the supporting structure (bearing stiffeners may be required).
- direct attachment to wall studs, or

The in-service performance of light steel joists should be controlled by the following four serviceability criteria.

Static criteria for the maximum permissible deflection of a single joist due to:

- imposed load, limited to (span/450).
- dead and imposed loads, limited to the lesser of (span/350) or 15mm.

Dynamic criteria:

- The natural frequency of the floor should be limited to 8Hz for dead load plus 0.2 x imposed load. This can be achieved by limiting the deflection of a single joist to 5mm for the given loading.
- The deflection of the floor (i.e. a series of joists plus the floor decking) when subject to a 1kN point load should be limited to the values in Table 2.

**Table 2:** Deflection with point loads of 1kN

Span (m)	Maximum deflection (mm)
3.5	1.7
3.8	1.6
4.2	1.5
4.6	1.4
5.3	1.3
6.2	1.2

The deflection of a single joist is dependent on the:

- overall floor construction
- number of effective joists that are deemed to share the applied 1kN point load (typical values are given in Table 3).

**Table 3:** Typical values

Floor configuration	Number of effective joists	
	400mm joist centres	600mm joist centres
Chipboard, plywood or oriented strand board	2.5	2.35
Built-up acoustic floor	4	3.5

**Ground floor construction**

Provision should be made to prevent ground moisture affecting light steel floors. This can be achieved by either:

- 50mm concrete or 50mm fine aggregate on a polyethylene membrane laid on 50mm sand blinding, or
- 100mm concrete.

Where necessary, oversite concrete should be protected against sulfate attack by the use of a polyethylene sheet DPM, not less than 1200 gauge (0.3mm) or 1000 gauge where assessed in accordance with Technical Requirement R3, properly lapped.

Floors should have a 150mm minimum void below the floor which is ventilated by:

- openings on at least two opposite sides
- 1500mm<sup>2</sup> per metre run of external wall or 500mm<sup>2</sup> per m<sup>2</sup> of floor area (whichever provides the largest area).

Where there is shrinkable soil, heave can occur. The minimum underfloor void ventilation requirement should be increased as follows:

- High potential – 150mm (300mm total)
- Medium potential – 100mm (250mm total)
- Low potential – 50mm (200mm total)

**Control of fire <sup>6.10.5</sup>**

**Walls and floors shall resist and control the spread of fire. Structural elements, fire stops and cavity barriers should have adequate resistance to fire and smoke. Issues to be taken into account include:**

- a) walls, floors and ceilings
- b) cavity barriers and fire stops
- c) materials suitable for fire stopping.

**Walls, floors and ceilings**

Fire resistance should be in accordance with:

- relevant building regulations
- the design.

Ceilings should provide the necessary fire protection to floors constructed with light steel joists. This requires one or two layers of plasterboard, with at least one being fire-rated. Where two layers of board are used:

- joints should be staggered between layers
- they should be attached using self-drilling, self-tapping screws.

**Cavity barriers and fire stops**

Service penetrations in floors between homes should be fire stopped and there should be no holes or gaps for smoke to penetrate once the fire stopping has been installed.

Horizontal cavity barriers should be protected by:

- a DPC tray with a 100mm minimum upstand
- a polyethylene-encased cavity barrier with a 100mm minimum upstand, or
- the eaves.

**Materials suitable for fire stopping**

Materials for fire stopping are acceptable where they are:

- specified in supporting documents to building regulations
- assessed in accordance with Technical Requirement R3.

**Acoustic performance** <sup>6.10.6</sup>**Walls and floors shall have adequate resistance to the passage of sound.**

Internal walls and floors should be in accordance with relevant building regulations.

**Separating walls**

Separating walls should be in accordance with the design. Gaps should be avoided in the:

- mineral wool quilt or batts
- wallboard layers
- fire stopping.

Services in, or adjacent to, separating walls should be installed in accordance with the design.

**Separating floors**

The floating part of a floor should be separated from the main structure and surrounding walls by a resilient layer.

Where boards are laid loose over insulation without battens, joints should be glued.

**Steel and fixings** <sup>6.10.7</sup>**Steel and fixings shall be suitable for the intended use. Issues to be taken into account include:**

- a) steel grade
- b) protection against corrosion
- c) connections and fixings
- d) holes and notches.

**Steel grade**

Steel should be grade:

- S280 to BS EN 10326
- S350 to BS EN 10326, or
- S390 steel with a nominal yield strength of 390N/mm<sup>2</sup> (when compliant with BS EN 10326).

**Protection against corrosion**

Steel should be pre-galvanised in accordance with BS EN 10326 (minimum 275 g/m<sup>2</sup> zinc coating). Joists should not be altered without the approval of the designer. Welded or flame cut edges should be cleaned and treated with a zinc-rich paint to prevent corrosion.

The junction between the ground floor joists and their support should be designed to maintain the durability of the floor. Light steel floor joists and ring beams in ground floors should be galvanised to 450g/m<sup>2</sup>. Alternatively, they can be galvanised to 275 g/m<sup>2</sup> with additional protection of a two-coat bitumen based coating to BS 1070, BS 3416 or BS 6949, or have a two-coat liquid asphaltic composition applied. Ring beams to ground floors should be totally protected, and joists protected for 300mm adjacent to an external wall support or ring beam.

**Connections and fixings**

Where two metals are to be joined, they should either be:

- compatible and not cause bimetallic corrosion, or
- isolated from each other.

Connections should be:

- properly installed
- securely made by clinching, crimping or by one of the methods detailed in Table 4
- justified in accordance with BS EN 1993-1-3 or a test method acceptable to NHBC.

**Table 4:** Types of connections

Type of connection	Relevant standard
Cleats	BS EN 1993-1-1
Countersunk bolts (tightened to the correct torque)	BS 4933
Ring shank nails	BS EN 10263
Rivets including self-piercing rivets	Manufacturer's recommendations
Screws	BS 5427
Welded connections	BS 5135 (using welding wire to BS 2901)
Zinc-plated bolts	BS 4190



**Holding-down devices**

Holding-down devices should be suitable for the environment they will be exposed to, and manufactured from:

- mild steel with zinc coating to BS 729 or BS 706
- stainless steel to BS EN 10095 (suitable for most environments).

**Holes and notches**

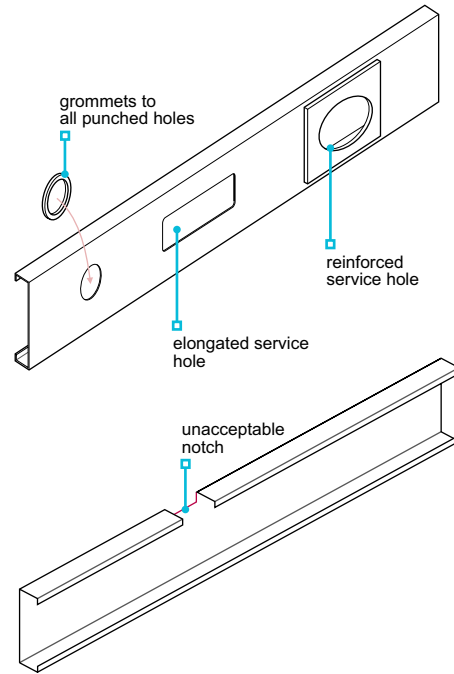
Joists should not be altered without the approval of the designer. Drilling or punching through the web should be carried out within recognised limits.

Unstiffened holes through the web should:

- have a minimum spacing equal to the depth of the member, and be a minimum of 1.5x the depth from the end of the member
- have rectangular holes not exceeding 40% of the overall depth of the member; the length of the hole should not exceed 3x the depth of the hole
- limit the diameter of circular holes to a maximum 60% of the depth of the member.

End notching of light steel joists may be required for the interconnection of trimming joists and should be in accordance with the design. Notches elsewhere in the span are not acceptable.

Also see Clause 6.10.19.



**Detailing of steel joist <sup>6.10.8</sup>**

**Steel joists, fixings and connections shall be suitably detailed and provide satisfactory performance. Issues to be taken into account include:**

- a) installation details
- b) support cleats
- c) prevention of roll.

**Installation details**

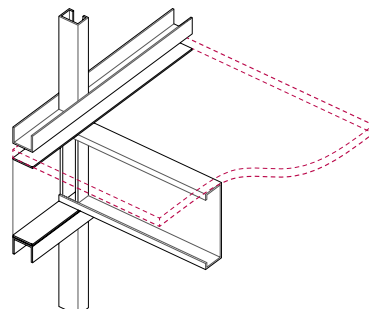
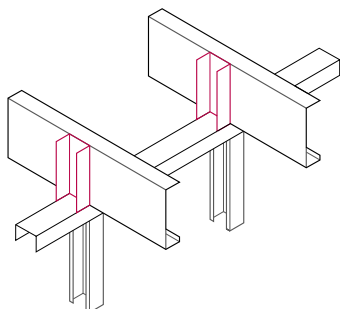
Joists should be:

- spaced as shown in the design
- accurately cut to length in the factory to ensure a tight fit
- joined with the correct type, size and number of fixings.

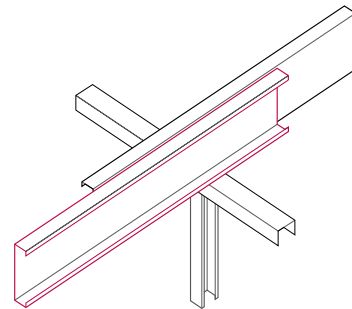
Where light steel joists are supported by steel joists, cleats or web stiffeners should be used in accordance with the design.

Joists may be doubled up to support partitions or to form trimmers.

Ends of floor joists directly supported on walls should be stiffened. Continuous joists on load-bearing intermediate walls should be reinforced as required by the design.



Where joists overlap on load-bearing intermediate walls should be fixed together with bolts or screws. This is to prevent the floor decking being pushed up, or the ceiling being cracked, when the cantilevered part of the joist moves upwards.

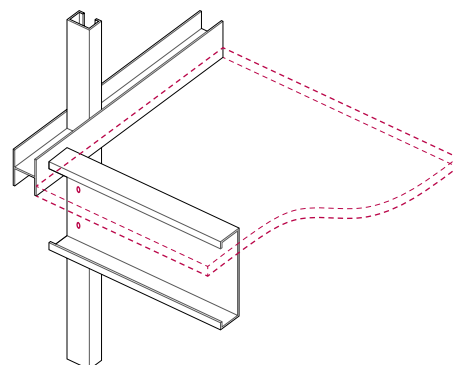
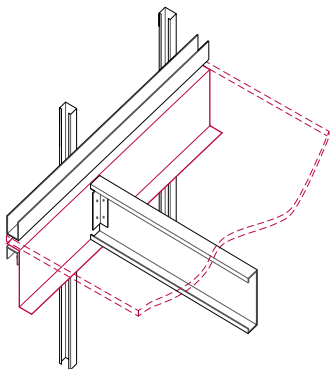


### Support cleats

Joist support cleats should:

- be of the correct type
- be fitted in the specified location
- use fixings as specified in the design.

Where required, web stiffeners should be properly fitted.



bolted web to web connection

Where joists are fitted directly to light steel wall studs, pre drilled holes should be correctly aligned before making the final connection.

Fixing holes should not be enlarged, and additional holes should not be cut without prior approval of the designer.

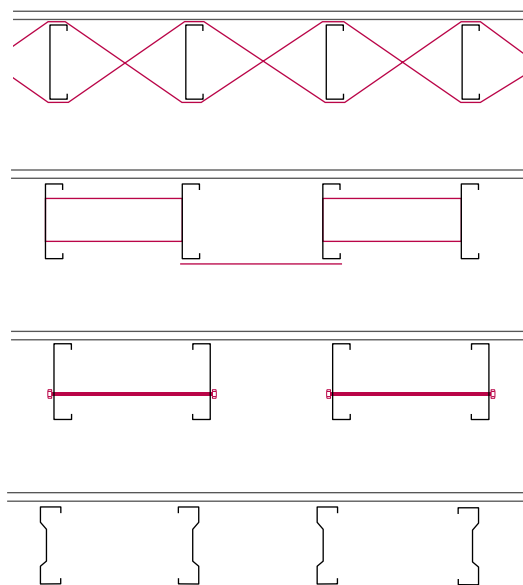
### Prevention of roll

Bridging and blocking should be provided in accordance with the design to prevent roll.

Floors constructed using joists with an asymmetric web, e.g. of C or Sigma profile, can cause the floor to roll. To avoid roll, unless otherwise specified in the design, one of the following alternatives should be used where the span exceeds 3.5m for C joists, or 4.2m for Sigma joists:

- A continuous line, or lines, of proprietary steel herringbone struts provided between the joists. The pairs of struts should have a physical gap between them so that they do not rub against each other at the cross-over point and create noise.
- Solid blocking provided to every third pair of joists with ties between them.
- Joists alternately reversed and tied together in pairs.
- Joists alternately reversed and continuous ties (e.g. resilient bar) fixed to the joist flanges.

Where joists bear onto steelwork or are supported by cleats, blocking is not necessary adjacent to the supports.



**Restraint** <sup>6.10.9</sup>

**Restraint strapping shall be provided in accordance with the design.**

Where external walls, not constructed from light steel framing, are to be stabilised by a connection to the floor, straps may be required. Straps will generally be fixed to the web of the joist, to suit the masonry courses.

Where joists run parallel to the wall, straps should be supported on noggings fixed between the joists. Straps should be placed at a maximum of 2m apart and carried over three joists. Packing should be provided between the wall and the first joist.

Straps should be fixed with suitable bolts, screws or rivets and should bear on the centre of bricks or blocks, not across mortar joints.

**Fixing floor decking and ceilings** <sup>6.10.10</sup>

*Also see: Chapter 6.4*

**Floor decking and ceilings shall be adequately fixed using a material of adequate strength and moisture resistance.**

Joist spacing and decking thickness should be compatible. Material standards and minimum board thicknesses for domestic loads (imposed load of 1.5kN/m<sup>2</sup>) are shown in Table 5.

**Table 5:** Joist spacing and decking type

Material	Standard	Thickness of decking (mm)	
		400mm joist centres	600mm joist centres
Chipboard	BS EN 312 moisture-resistant type P5	18	22
Plywood	BS EN 636	15	18/19
Oriented strand board type OSB3	BS EN 300	15	18/19

Decking materials not listed should comply with Technical Requirement R3.

Oriented strand board should be laid with the stronger axis at right angles to the supports.

In England and Wales, the thicknesses listed above may not achieve the 15 kg/m<sup>2</sup> mass required to meet sound insulation requirements.

Fixings and supports should be as recommended by the manufacturer.

Flooring should be fixed at maximum 300mm centres using the following:

- Self-drilling or self-tapping screws.
- Ring shank nails, or
- Other approved fixings.

Tongue and groove joints should be glued.

Plasterboard should be fixed in accordance with Chapter 9.2 'Wall and ceiling finishes', using self-drilling, self-tapping screws.

**Moisture control** <sup>6.10.11</sup>

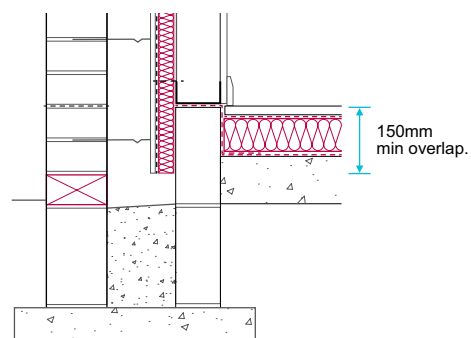
**The structure shall be adequately protected from the effects of moisture. Issues to be taken into account include:**

- a) cavities in external walls
- b) DPCs, DPMs and cavity trays.

**Cavities in external walls**

A clear cavity should be provided to reduce the risk of rain penetrating the frame.

The minimum cavity widths (measured between the claddings and sheathings) to suit the cladding type should be provided in accordance with Table 6.



**Table 6:** Minimum cavity widths

Cladding	Cavity width
Masonry	50mm nominal
Render on backed lathing	25mm nominal
Vertical tile hanging without underlay	No vertical cavity required where a breather membrane is provided
Other cladding <sup>(1)</sup>	15mm nominal

Notes

1 See Chapter 6.9 'Curtain walling and cladding'

The cavity should:

- extend at least 150mm below the DPC
- be kept clear to allow drainage
- be provided with weep holes or other suitable means of drainage where necessary.

### DPCs, DPMs and cavity trays

DPCs, DPMs and cavity trays should:

- be provided at openings to prevent rain penetration
- be installed underneath the full width of the lowest section of framing, e.g. all ground floor walls and internal partitions, to protect the steel from corrosion due to moisture
- be wide enough to lap with the DPM.

Materials acceptable for use as DPCs include:

- BS 6515 polyethylene
- BS 6398 bitumen
- materials assessed in accordance with Technical Requirement R3.

### Insulation <sup>6.10.12</sup>

*Also see: BRE Report Thermal insulation: avoiding risks*

**Insulation materials shall be correctly installed, be of a suitable thickness to comply with building regulations and reduce the risk of interstitial condensation.**

Insulation should:

- be inert, durable, rot and vermin proof and should not be adversely affected by moisture or vapour
- cover the whole external face of the wall
- extend 150mm below the bottom rail to minimise thermal bridging and maintain a warm frame
- be tightly butted with joints of rigid board insulation taped, where required by the design.

Foil-faced insulation boards with an integral facing on one side only should be fixed with the foil face on the cavity side.

**Table 7:** Acceptable insulation material

Material	Relevant standard
Mineral wool	BS EN 13162
FR (flame retardant) grade expanded polystyrene	BS EN 13163
FR (flame retardant) grade extruded polystyrene	BS EN 13164
Rigid polyurethane foam and polyisocyanurate	BS EN 13165
Phenolic foam	BS EN 13166
Cellular glass	BS EN 13167
Other insulation materials	Technical Requirement R3

In England and Wales, account should be taken of Accredited Construction Details for Part L.

**Vapour control layers** 6.10.13

**Vapour control layers shall restrict the passage of vapour from within the home to the steel frame and be correctly installed.**

Vapour control layers should be provided, unless a condensation risk analysis in accordance with BS 5250 shows it is not necessary. Where they are provided, vapour control layers should be:

- 500g polyethylene sheet, vapour control plasterboard, or material assessed in accordance with Technical Requirement R3
- fixed on the warm side of the wall insulation and frame
- in accordance with the design
- placed to cover the external wall, including base rails, head rails, studs, lintels and window reveals
- overlapping the base rail
- fully sealed and punctures made good.

Where polyethylene sheet is used:

- each joint in the vapour control layer should be located on studs or noggings and lapped by 100mm minimum
- double-sided tape or adhesive should be used as a temporary fixing before the wall board is fixed.

Where vapour control plasterboard is used:

- joints between sheets should be positioned on studs or noggings
- care should be taken not to displace the vapour control material when cutting vapour control plasterboard.

**Breather membranes** 6.10.14

**Breather membranes shall be capable of allowing vapour to pass into the cavity, and provided to protect the sheathing and frame from external moisture.**

Breather membranes should be:

- vapour resistant to less than 0.6MNs/g (according to a BS 3177 test at 25°C and 75% relative humidity)
- capable of resisting water penetration
- self-extinguishing
- durable
- adequately strong when wet to resist site damage
- installed so that each joint is protected and moisture drains outwards
- lapped to a minimum of 100mm at horizontal joints and a minimum of 150mm at vertical joints
- Type 1 to BS 4016 when in areas of very severe exposure.

**Construction of load-bearing walls and external infill walls** 6.10.15

**Construction of load-bearing walls and external infill walls shall ensure adequate stability. Issues to be taken into account include:**

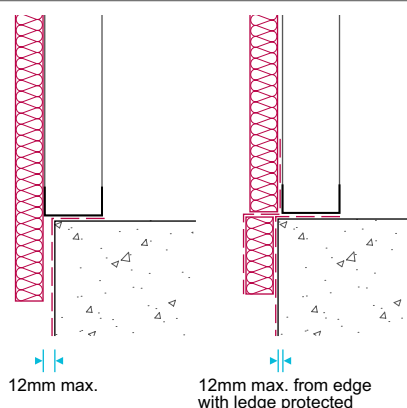
- a) preparation
- b) anchoring
- c) panels, cladding and boards.

**Preparation**

The following should be in accordance with the design:

- The setting out of the structure onto which the light steel frame is to be erected.
- The transfer of loads from the light steel frame.

The supporting structure may have local deviations in level along its length, and some packing will be required to achieve the required tolerances and to provide for effective load transfer.



**Table 8:** Acceptable methods of packing under frames

Gap under base rail	Acceptable packing
Less than 10mm	Provide shims under each stud position.
10-20mm	Provide shims under each stud position, and grout under the whole length of the base rail with cement: sand mortar.
More than 20mm	Obtain advice from the frame designer/manufacturer. Remedial work to the substructure may be required before erection commences.

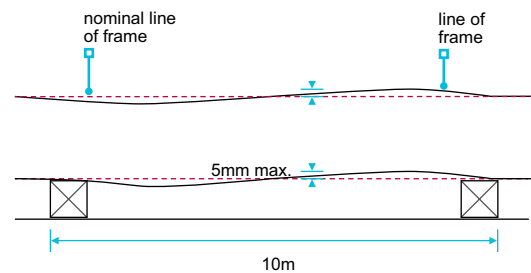
Shims should:

- be of pre-galvanised steel
- not be of plastic or timber.

Wall frames should be checked to ensure that they are dimensionally accurate before erection commences.

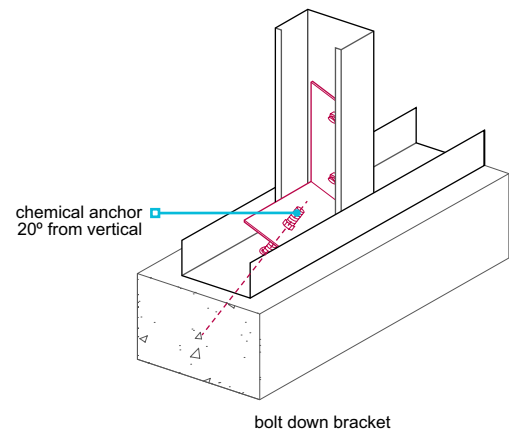
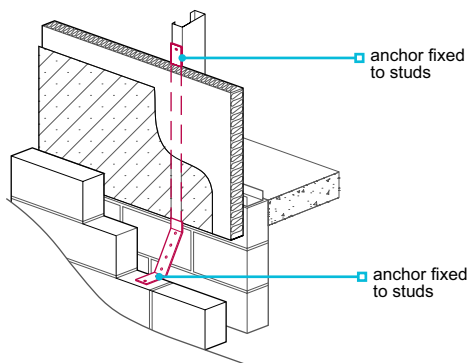
Light steel framing should be correctly positioned, square and plumb, and within the following tolerances:

- The vertical position of members should be within +/-5mm per storey relative to the base.
- The horizontal position of base rails should not vary in alignment by more than 5mm in 10m.



### Anchoring

The frame should be anchored to resist both lateral movement and uplift in accordance with the design.



Anchoring should ensure:

- that appropriate edge details are provided to avoid spalling of masonry slabs or slabs
- fixings into masonry are into solid concrete blocks with a minimum crushing strength of 7.3N/mm<sup>2</sup> and positioned to receive fixings.

Where the design incorporates gas membranes (methane or radon), fixings should not puncture them, but where this is unavoidable, the penetration should be sealed.

### Construction of non load-bearing walls <sup>6.10.16</sup>

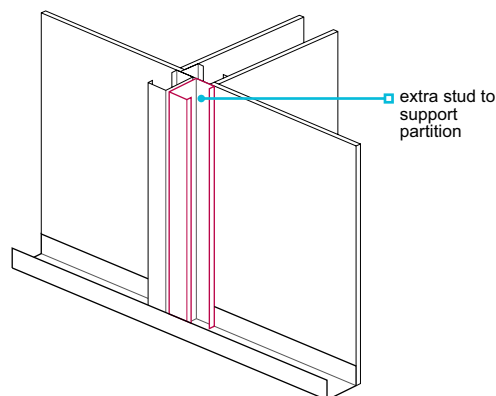
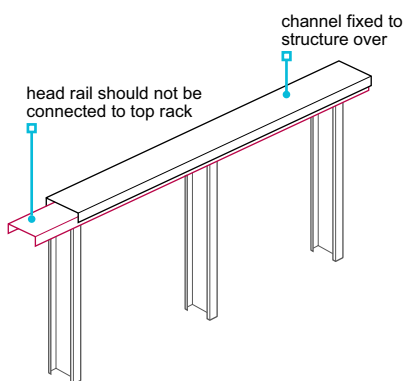
**Non load-bearing walls shall be suitably constructed.**

Acceptable construction includes light steel partitions using studs, and head and base rails, from a minimum section of 43mm x 32mm x 0.45mm, with:

- 9.5mm plasterboard with studs spaced at a maximum of 450mm, or
- 12.5mm or thicker plasterboard with studs spaced at a maximum of 600mm.

Noggings or straps should be provided as required to support fittings, such as radiators, wall-mounted boilers, sanitary fittings, kitchen units, etc. Non load-bearing partitions should not be wedged against floor joists, ceiling joists or roof trusses. Allowance should be made for the floor joists, ceiling joists or roof trusses to deflect so that the partition does not become load-bearing. They should be:

- constructed in accordance with the design
- correctly positioned, square and plumb
- supported on a structural floor, but not a floating floor that incorporates a compressible layer, unless specifically designed for that purpose
- fixed to the floor at the head, to each other and to abutting walls
- provided with extra studs at openings where required
- finished in accordance with Chapter 9.2 'Wall and ceiling finishes'.



### Panels, cladding and boards <sup>6.10.17</sup>

**Panels, cladding and boards shall be compatible with the steel frame, be of a suitable thickness for the intended use, and be adequately fixed and installed.**

In external walls, a clear cavity should be provided between the sheathing and the cladding. The cavity should:

- be drained
- have cavity trays and weep holes installed where the cavity is not fully maintained, e.g. at cavity barriers
- be kept clean, free of obstructions and capable of draining freely
- have drainage at the base of the cladding system equivalent to 500mm<sup>2</sup> /m run, e.g. for masonry, one open perpend every 1.5m
- have drainage openings placed to prevent the ingress of rain.

Wall panels should be:

- fixed in accordance with the design
- securely fixed together and to floors.

#### Masonry cladding

Masonry cladding should:

- not be supported by the light steel framed walls unless shown in the design
- be tied to the light steel framed walls with flexible wall ties fixed through to the studs
- be constructed in accordance with Chapter 6.1 'External masonry walls'
- be provided with soft joints to allow for differential movement.

To allow for movement, a 1mm gap per metre of masonry should be provided at openings and soffits.

#### Lightweight cladding

Lightweight cladding should be supported by:

- the light steel framed walls on battens, or
- other suitable means.

#### Wallboards

Wallboards should be:

- fixed in accordance with the design and the manufacturer's recommendations
- attached to light steel studs using self-drilling, self-tapping screws at a maximum of 300mm centres.

In addition to the general guidance for wallboards, plasterboard should:

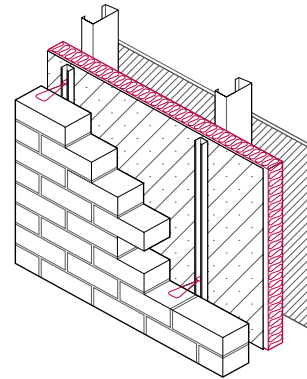
- be fire-rated where used to provide fire resistance
- comply with BS 1230 and be in accordance with Chapter 9.2 'Wall and ceiling finishes'
- be a minimum of 9.5mm for stud spacings up to 450mm
- be a minimum of 12.5mm for stud spacing up to 600mm.

**Wall ties** 6.10.18

**Wall ties shall be suitable to connect the steel frame to the cladding.**

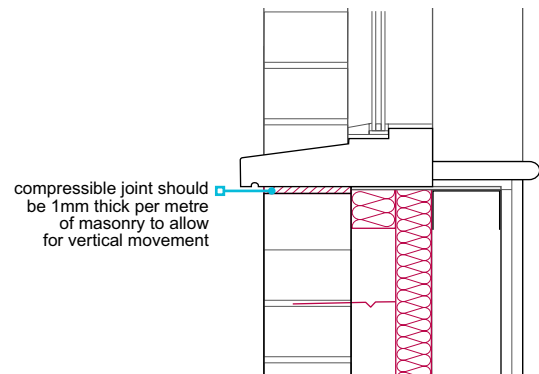
Generally, wall ties should be:

- fixed to the studs and not the sheathing
- inclined away from light steel framing
- austenitic stainless steel and of a type which accommodates the differential movement between the light steel frame and the cladding, or assessed in accordance with Technical Requirement R3.



Wall ties for masonry cladding should be:

- installed at a minimum density of 3.7 ties/m<sup>2</sup>, e.g. spaced at a maximum of 600mm horizontally and 450mm vertically
- spaced at jambs of openings, a maximum of 300mm vertically within 225mm of the masonry reveal (additional studs may be needed to achieve this)
- kept clean and free from mortar droppings.

**Services** 6.10.19

**Services shall be adequately protected from damage.**

Service mains and service outlets should be:

- designed to ensure the fire resistance of walls and floors is not impaired
- installed in accordance with the design
- on the warm side of the insulation.

Light steel studs should not be notched to accommodate services. Holing of structural light steel members should be carried out in accordance with this chapter. On-site hole cutting should be avoided, as badly cut edges can have an adverse effect on the durability of the frame and may cause damage to pipes and cables.

Grommets should be used around the edge of service holes to protect electrical cables and reduce the risk of bimetallic corrosion between the light steel framing and copper pipes. Swaged holes for electric cables and plastic piping do not require grommets.

In Scotland, services are not permitted within:

- framed separating walls
- separating wall cavities.

**Further information** 6.10.20

- *The Steel Construction Institute (SCI), Silwood Park, Ascot, Berkshire, SL5 7QN*



# Render

## CHAPTER 6.11

This chapter gives guidance on meeting the Technical Requirements for factory-made and traditional render applied to external walls, and render onto board backgrounds.

Render intended for below ground waterproofing is outside the scope of this chapter (see Chapter 5.4 'Waterproofing of basements and other below ground structures'). Chapter 6.9 'Curtain walling and cladding' contains guidance for insulated render systems.

6.11.1	Compliance	01
6.11.2	Provision of information	01
6.11.3	Weather conditions	02
6.11.4	Backgrounds	03
6.11.5	Accommodation of movement	03
6.11.6	Mixes	05
6.11.7	Detailing	07
6.11.8	Render onto board backgrounds	09
6.11.9	Finishes	11



Raising Standards. Protecting Homeowners

## Introduction

This chapter is arranged in sections covering:

- site and factory-made render
- render onto board backgrounds
- detailing.

## Definitions for this chapter

<b>Background</b>	The surface to which the render is applied.
<b>Base coat</b>	The first render coat.
<b>Cured</b>	The finished render state when all chemical reactions have taken place.
<b>Decorative finishes</b>	An aesthetic finish not generally contributing to weathertightness.
<b>Dry dash</b>	Aggregate applied to finish the render.
<b>Factory-made</b>	Render mortar arriving on site premixed, generally including admixtures and colouring, and either ready to use or requiring only the addition of water.
<b>Final coat</b>	The last render coat.
<b>Movement joint</b>	A joint designed to accommodate predicted movement in the background or render.
<b>Preparation coat</b>	An application to provide an appropriate key or bond, including a spatterdash or stipple coat.
<b>Proprietary render systems</b>	Renders and their specified backgrounds with proven compatibility, which fall outside the guidance given for site and factory-made renders.
<b>Ribbed metal lathing</b>	Metal lathing that can be used as a carrier for render.
<b>Site-made</b>	Renders made on site to recognised designated or prescribed mix proportions.
<b>Structure</b>	Structural elements of the building providing support to the render or proprietary render system.
<b>Substrate</b>	The wall composition which offers support to the background intended to be rendered (the substrate and background may sometimes be the same).
<b>Undercoat</b>	The coats preceding the final coat.
<b>Wet dash</b>	A traditional render consisting of aggregate bound in slurry applied to the undercoat prior to setting.

## Compliance <sup>6.11.1</sup>

*Also see: BS EN 13914 and BS 8000-0*

**Render, including site-made, factory-made and render onto board backgrounds shall comply with the Technical Requirements.**

Render that complies with the guidance in this chapter will generally be acceptable.

## Provision of information <sup>6.11.2</sup>

**Designs and specifications shall be produced in a clearly understandable format, include all relevant information and be distributed to all appropriate personnel.**

Design and specifications should be issued to site supervisors, relevant specialist subcontractors and/or suppliers and, where relevant, include the following:

- A full set of drawings indicating areas to be rendered, and construction details, e.g. the position of movement joints and how interfaces are formed.
- The render manufacturer's technical information, including parts of the system design manual or installation guidance relevant to the specific site and construction type.
- Mix proportions for site-made render.
- Details of the substrate and background.
- Details of any technical assessments (i.e. third-party certifications).
- Details of interfaces and abutments, such as joints, junctions and service penetrations.
- Ancillaries that form part of a rendering system.

**Table 1:** Process chart for the application of site - and factory-made render to masonry backgrounds

Process	Steps	See clause
Structure design	Identify a suitable background material compatible with the intended render finish and consider any preparation requirements	6.11.4
	↓	
	Consider how movement will be controlled, i.e. are movement joints or bed joint reinforcement needed?	6.11.5
Render design	↓	
	Select an appropriate render strength that is compatible with the background	6.11.6
	↓	
	Determine the exposure zone which will influence the render's thickness	6.11.6
Construction	↓	
	Protect the background from adverse weather conditions at the earliest opportunity during and following construction	6.11.3
	↓	
	Assess the likely weather conditions prior to and after rendering	6.11.3
	↓	
	Assess the background, e.g. suction and surface preparation, and apply a preparation coat where necessary	6.11.4
	↓	
	Protect the completed render as it cures	6.11.3

### Weather conditions <sup>6.11.3</sup>

**Rendering shall only be carried out in suitable weather conditions, unless appropriate precautions are taken.**

Consideration should be given to likely weather conditions and, where required, measures taken to allow render to cure satisfactorily.

When applying render in wet conditions:

- the background should not be saturated
- downpipes or temporary downpipes should be used to prevent the background or completed render from becoming saturated
- curing render should be protected from heavy rainfall
- specialist preparation coats should be used in accordance with the manufacturer's recommendations.

When applying render in hot conditions the following precautions should be considered:

- avoid curing render from being directly exposed to strong sunlight
- lightly spray the render with clean water to prevent rapid drying.

When applying render in cold conditions:

- the air temperature should be at least 2°C and rising
- the background should be free from visual signs of frost
- the background should not be saturated.

Where the air temperature is at, below or likely to fall below 5°C, appropriate precautions such as covering with a hessian sheet should be used to protect curing render.

Factory-made render should be installed in accordance with the manufacturer's recommendations for weather conditions.

Acrylic renders have different curing requirements which should be taken into account.

**Backgrounds** 6.11.4

**Backgrounds shall be appropriate for their intended purpose and suitably prepared to receive render.**

**Issues to be taken into account include:**

- a) preparation of masonry backgrounds
- b) preparation of clay brick backgrounds
- c) ribbed metal lath.

**Preparation of masonry backgrounds**

Masonry backgrounds should be constructed in accordance with Chapter 6.1 'External masonry walls' and include DPCs and cavity trays. The thickness of single-leaf masonry walls should be in accordance with PD 6697.

The surface to be rendered should be free from dust, loose particles, efflorescence and organic growth, and, where applicable, be prepared in accordance with the render manufacturer's recommendations.

Masonry backgrounds with a smooth surface or close texture should be treated to provide an adequate key by either applying:

- lath, or
- a spatterdash or stipple coat.

The suction of the block should be appropriate for rendering. High or low suction will generally require a preparatory coat. The likely suction of the block can be gauged by applying a small quantity of water to the surface and observing the effects:

- Water being absorbed instantly is an indication of high suction.
- Water running from the surface with little absorption suggests the background has low suction.

A spatterdash coat typically comprises cement and sand at a ratio of 1:3 mixed with water and often a bonding agent, such as styrene butadiene rubber (SBR) or ethylene vinyl acetate (EVA). The mix should be applied by dashing onto the background to give a rough texture approximately 3-7mm thick.

Generally, raking out mortar joints to blockwork will not sufficiently improve the key, and may extend the curing time of the base coat.

**Preparation of clay brick backgrounds**

The brick manufacturer's recommendations for rendering should be followed.

Where S1 bricks are used, the render mix should resist sulfate.

To provide an appropriate bond, clay brick backgrounds with a water absorption rate of between 9% and 15% should generally have sufficient suction to provide a mechanical key. Alternatively, when rendering onto bricks, one or more of the following methods of improving the key can be adopted:

- Keyed bricks used.
- Mortar joints raked out to a depth of 10-12mm (although this may increase curing time).
- A spatterdash coat applied.

Render on an external leaf of clay bricks (F2,S1 or F1,S1 designation bricks to BS EN 771) in severe or very severe exposures is not permitted where the cavity is to be fully filled with insulation.

**Ribbed metal lath**

Ribbed metal lath should be:

- fixed in accordance with the manufacturer's recommendations
- fixed with the correct side to be rendered facing out
- supported at 350mm and up to 600mm centres for stiffer metal profiles
- fixed with a 25mm drained and vented cavity when applied to framed structures
- austenitic stainless steel to BS EN 10088-1.

Render onto ribbed metal lath can be vulnerable to damage where impact is likely to occur, such as beside communal paths. Appropriate reinforcement may be used to help improve the render's impact resistance.

**Accommodation of movement** 6.11.5

*Also see: PD 6697*

**Rendered walls shall be detailed to reduce the risk of damage due to movement in the background. Issues to be taken into account include:**

- a) movement in masonry background
- b) dissimilar materials
- c) movement in ribbed metal lath render.

The construction should include appropriate measures to reduce the risk of damage to the render caused by movement in the background, such as shrinkage, thermal or differential movement. The designer should follow the guidance in this chapter, together with the render/background manufacturer's recommendations. Alternatively, provision for movement should be designed by an engineer in accordance with Technical Requirement R5.

Areas of the building to be rendered should be identified prior to construction, and movement control considered as part of the design.

### Movement in masonry background

Render and masonry backgrounds should be detailed to reduce the likelihood of cracking and crazing in the render. Issues to be taken into account include:

- the potential for movement in the background and render
- size, quantity and positioning of openings
- compatibility with the background
- density of the masonry
- the size and geometry of rendered panels
- the orientation of the building
- thermal shock
- moisture content of the materials
- exposure conditions.

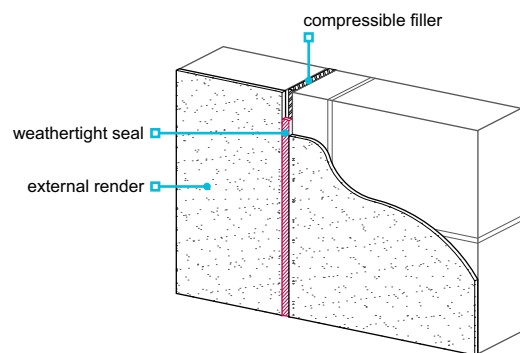
Where length/height ratios are greater than 3:1, consideration should be given to providing suitably designed:

- movement joints, or
- bed joint reinforcement.

Where movement joints are provided, they should:

- be continued through the background and render (including any horizontal beads)
- be made weathertight with an appropriate sealant
- not align with openings such as windows, doors or meter boxes.

Bed joint reinforcement should be provided in the first two courses of the external masonry leaf above and below any opening. Where possible, the reinforcement should project 600mm beyond the opening.



**Table 2:** Concrete block categorisation

Category	Compressive strength of the blockwork	Dry density
Low density aircrete	2.9-3.6N/mm <sup>2</sup>	<500kg/m <sup>3</sup>
Normal density aircrete	3.6-9.0N/mm <sup>2</sup>	500kg/m <sup>3</sup> +
Ultra lightweight aggregate	3.6-7.3N/mm <sup>2</sup>	<950kg/m <sup>3</sup>
Lightweight aggregate	3.6-7.3N/mm <sup>2</sup>	950-1500 kg/m <sup>3</sup>
Dense aggregate	7.3N/mm <sup>2</sup> +	1,500kg/m <sup>3</sup> +

**Table 3:** Preparation of blockwork backgrounds<sup>(1)</sup>

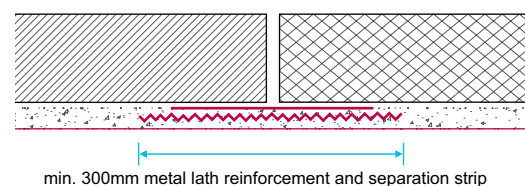
Category	Normal movement joint spacing	Maximum distance of joint from restrained end, i.e. corners	Suction control
Low density aircrete	Specialist advice required <sup>(2)</sup>		
Normal density aircrete	6m	3m (half normal spacing)	Yes
Ultra lightweight aggregate	6m	3m (half normal spacing)	Not generally required
Lightweight aggregate	7.5 - 9m	Half normal spacing	Not generally required
Dense aggregate	7.5 - 9m	Half normal spacing	Not generally required

- Notes:
- 1 The guidance in this table is generally acceptable for render coats in accordance with Table 5 and factory-made one-coat render based on 1:1:6 mix = 3.5N/mm<sup>2</sup>.
  - 2 Specialist advice from the block and render manufacturer should be sought.
  - 3 Specialist advice should be sought where clay brick backgrounds are used.

### Dissimilar materials

Backgrounds should not be constructed from materials of different densities. Where possible, render should not be continuous across dissimilar materials. Where this cannot be avoided the render should:

- be stopped at appropriately formed movement joints, or
- have austenitic stainless steel lath reinforcement carried across the joint with a separation strip, such as building paper, behind.



Where significant differential movement is likely to occur, such as the junction between masonry and board backgrounds, render should be stopped either side of an appropriately formed joint.

### Movement in ribbed metal lath render

To avoid cracking, ribbed metal lath backgrounds should be divided with movement joints into bays no more than 5m wide and:

- site-made render should be applied in three coats
- factory-made render should be applied in accordance with the manufacturer's recommendations.

### Mixes <sup>6.11.6</sup>

Also see: Chapter 6.1

**The render mix shall be appropriate for the intended purpose, be compatible with the background and be designed to minimise the risk of de-bonding, cracking and crazing. Issues to be taken into account include:**

- |                                       |                                    |
|---------------------------------------|------------------------------------|
| a) sand                               | e) application of site-made render |
| b) mix design                         | f) factory-made renders            |
| c) admixtures and bonding agents      | g) lime.                           |
| d) coat thickness of site-made render |                                    |

Render coats should not be stronger than the background or any previous coat to which they are applied. Weaker coats can be achieved by reducing the cement content of each coat or by using the same mix but decreasing the coat thickness.

Potable water should be used for mixing render.

### Sand

Sand for render should be well-graded category 2, in accordance with BS EN 13139. Sand with excessive fine material, clay or silt can shrink and crack so should be avoided.

A sharp gritty or coarse sand is required for strength in the backing coats, but finer sand should be used for the finishing coat.

Typical sand grades should be:

- 5mm down to 0.075mm – undercoat(s)
- 1.18mm down to 0.075mm – final coat.

### Mix design

Designation ii, iii and iv (strength class M6, M4 and M2) mixes are generally used for rendering.

Stronger mixes are generally more moisture resistant; however, they are also more prone to shrinkage, which increases the likelihood of the render cracking. Weaker mixes may be appropriate for weaker backgrounds in less exposed zones.

For exposure zone classification, see Clause 6.1.6.

**Table 4:** Designation mix proportions for cement-based mixes

	Mix designation	Mortar compressive strength class equivalent	Mix proportions by volume based on damp sand				Masonry cement:sand <sup>(1)</sup>
			Cement:lime:sand	Cement:ready-mixed lime/sand <sup>(1)</sup>	Cement:sand <sup>(1)</sup> (using plasticiser)	Ready-mixed lime:sand	
Weaker – stronger	i	M12	1:¼:3	1:12	1:3	-	-
	ii	M6	1:½:4 - 4½	1:9	1:4 - 4½	1:3 - 4	1:2½ - 3½
	iii	M4	1:1:5 - 6	1:6	1:5 - 6	1:5 - 6	1:4 - 5
	iv	M2	1:2:8 - 9	1:4½	1:8 - 9	1:7 - 8	1:5½ - 6½
	v	-	1:3:10 - 12	1:4	1:10 - 12	-	-

- Notes:
- 1 With fine or poorly graded sands, the lower volume of sand should be used.
  - 2 Where soluble salts could be present in the background, mixes should have sulfate-resisting properties.
  - 3 Where pigments are specified, batching should be undertaken with care to ensure colour consistency pigments to BS EN 12878 can be used but should not exceed 10% of the cement weight, or 3% where carbon black is used (white Portland cement may be used).

Render mixes should be:

- in accordance with BS EN 13914 'Design, preparation and application of external rendering and internal plastering'
- appropriate to the strength of the background
- checked against the specification
- of adequate strength and thickness to achieve durability.

Where enhanced water-resisting properties are required:

- Portland cement with a waterproofing agent already incorporated may be used in the undercoat, or
- a waterproofing agent should be added to the render mix in accordance with the manufacturer's recommendations.

Rendering mortar should not be left turning over in the mixer for longer than necessary.

### Admixtures and bonding agents

Admixtures and bonding agents should:

- be assessed in accordance with Technical Requirement R3
- be compatible with the render
- be used in accordance with the manufacturer's recommendations
- not be used with factory-made renders without the prior approval of the render manufacturer.

The effect on the adhesion of subsequent render coats should be considered when water-repelling agents are used.

Plasticisers and air entrainers should comply with BS EN 934 and not be used in mortars containing masonry cement.

### Coat thickness of site-made render

The number of coats should be designed to take account of the background and exposure conditions of the site.

The mix and its application should be suitable for the specific background. Items to consider include:

- the number and thickness of coats
- the strength of the coat (subsequent coats should be weaker than the background or the previous coat).

Render should have a nominal total finished thickness of not less than:

- 16mm for sheltered and moderate exposure zones, or
- 20mm for severe and very severe exposure zones.

**Table 5:** Site-made render designation and typical thickness

	Typical two-coat application
<b>Normal density aircrete</b>	
Undercoat	8-12mm designation iii (M4)
Final coat	6-8mm designation iv (M2) <sup>(1)</sup>
<b>Ultra lightweight and lightweight aggregate blockwork</b>	
Undercoat	8-12mm designation iii (M4)
Final coat	6-8mm designation iv (M2) <sup>(1)</sup>
<b>Dense aggregate blockwork</b>	
Undercoat	8-12mm designation ii (M6)
Final coat	6-8mm designation iii (M4)
<b>Clay brick</b>	
Undercoat	8-12mm designation ii (M6)
Final coat	6-8mm designation iii (M4)
<b>Ribbed metal lath</b>	
First coat	8-12mm designation i (M12)
Undercoat	10-12mm designation ii (M6)
Final coat	6-8mm designation ii (M4)

Notes:

- 1 Designation iii (M4) should be used for the final coat in severe or very severe exposure zones.
- 2 For block classifications, see Table 2.
- 3 Specialist advice should be sought for low density aircrete backgrounds.

Where a three-coat render is used, this should include a second undercoat that is:

- the same thickness but a slightly weaker mix than the first undercoat, or
- a slightly thinner coat of the same strength mix.

### Application of site-made render

When applying render, previous coats should be allowed to cure before applying the next coat (typically three to four days).

To avoid surface crazing:

- properly graded sand should be used with limits on fine sand proportions
- overworking (polishing) of the render should be avoided, as this causes laitance to be drawn to the surface.

Surfaces should be appropriately prepared to receive following coats. This can be achieved by either combing or scratching. The final coat should be applied to an undercoat that is suitably keyed.

The size of the background to be rendered should be assessed to determine if it can be rendered in the time available. This will help to establish the most suitable location for day joints.

The final coat should be of uniform thickness and not used to even out irregularities, which should be accommodated in previous coats.

### Factory-made renders

Factory-made renders should be applied in accordance with the manufacturer's recommendations, including those for ancillary components.

Factory-made renders with a declared mix in accordance with Table 4, applied to the thickness recommended in Table 6, and that otherwise comply with the recommendations for site-made renders, will generally be acceptable to NHBC.

**Table 6:** Minimum thickness of factory-made single-coat renders

Background	Sheltered and moderate exposure zone	Severe and very severe exposure zone
Single-leaf masonry wall	20mm	In accordance with the render manufacturer's recommendations.
Masonry cavity wall partially filled	15mm	
Masonry cavity wall fully filled	20mm	
Lath <sup>(1)</sup>	15mm	

- Notes:
- Lath backgrounds generally require two coats.
  - Alternative single-coat thicknesses may be acceptable when accompanied by appropriate third-party assessment in accordance with Technical Requirement R3.

### Lime

Render mixes containing hydrated lime can improve the ability of the render to accommodate movement, improving resistance to cracking and crazing. The use of lime should be in accordance with BS EN 459.

Natural hydraulic lime (NHL) is used without cement, which can allow greater moisture vapour movement through the structure. Specialist advice may be required for the use of NHL render.

### Detailing <sup>6.11.7</sup>

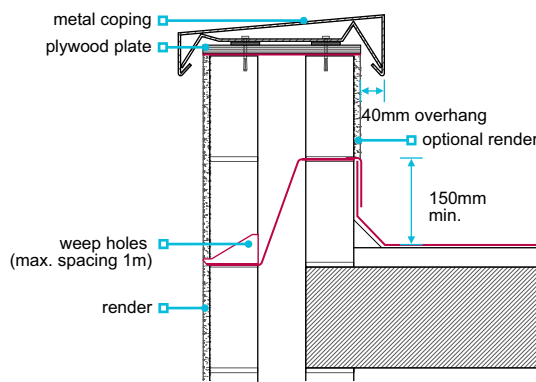
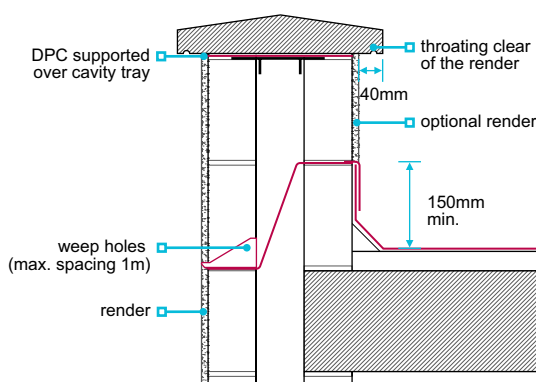
**Rendering shall be detailed to ensure appropriate weathertightness and durability. Issues to be taken into account include:**

- |                                |                                  |
|--------------------------------|----------------------------------|
| a) copings, cappings and sills | e) exposed elements              |
| b) abutments and interfaces    | f) ancillary items               |
| c) weepholes                   | g) render below the DPC          |
| d) detailing at openings       | h) resistance to sulfate attack. |

### Copings, cappings or sills

Render should be protected from damage by copings, cappings or sills made of a material of low permeability or with suitably detailed DPCs. A minimum 40mm projection with a throating or drip detail should be provided to all copings, cappings and sills.

Extending sills or sub-sills beyond window reveals can help to disperse water and prevent staining.





### Abutments and interfaces

Where raked roof abutments occur against a rendered masonry wall, preformed cavity trays and appropriate flashings should be provided. Clauses 6.1.17 and 7.2.20 contain guidance for stepped cavity trays and flashings to masonry walls.

Render abutting exposed features, such as stone string courses or quoins, should be finish neatly without gaps.

Abutments between render and exposed masonry should be detailed to prevent moisture passing in behind the render or adversely affecting the building.

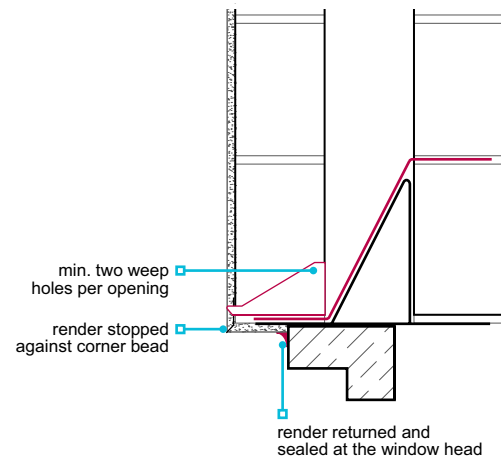
When rendering into window or door frames, the render should be stopped against a bead and sealed, or a bead of sealant applied between the frame and render.

### Weepholes

Weepholes should be provided:

- where required for ventilation to timber frame construction
- to the last tray at stepped abutments
- where rendering is returned back into the window or door head (weepholes are not required where the render is not returned)
- to cavity trays on parapet walls.

To prevent staining, weepholes should be of a type which restricts the entry of wind-driven rain.

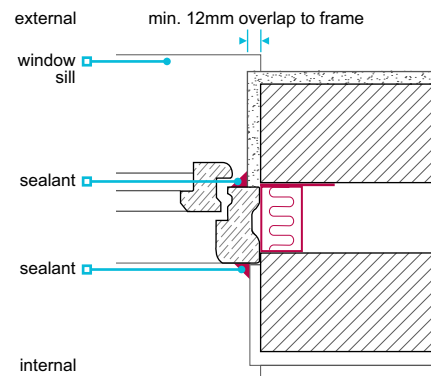


### Detailing at openings

Design features around openings and at the head of the rendering should provide shelter and help shed water away from the surface below.

In areas of very severe exposure, and in Scotland, a check reveal should be provided at openings.

Proprietary render systems should be detailed at abutments in accordance with the manufacturer's recommendations.



### Exposed elements

Render to exposed masonry elements, such as parapets, freestanding walls, pillars, retaining walls or chimneys, should be of a type appropriate for severe exposure conditions.

When rendering both sides of freestanding or parapet walls of single leaf construction, care should be taken to prevent damage caused by moisture becoming trapped. For example:

- the detailing should prevent the masonry from becoming saturated
- the wall should be protected from rain during construction
- rendering both sides of single leaf walls in areas of very severe exposure to frost attack should be avoided (see Clause 6.1.6c).

Bricks with S1 or S0 designation are not recommended for exposed elements that are to be rendered.

### Ancillary items

Stop beads and render stops should be austenitic stainless steel or PVC. Long runs of steel beads and stops should be avoided due to their expansion potential.

Corner beads should have an appropriate projection to prevent thin tapering of the render which reduces the its overall thickness.

Beads should be:

- adhesive-fixed using a material appropriate for external use and in accordance with the manufacturer's recommendations, or
- mechanically fixed using suitably durable fixings.

### Render below the DPC

To prevent damage caused by prolonged periods of wetting -, it is preferable to stop the render at DPC level. Where rendering is continued below the DPC, the following precautions should be taken:

- for site-made render, use a stronger mix (M4) that is sulfate resisting, or
- factory-made render used in accordance with the manufacturer's recommendations.

Consideration should be given to providing:

- appropriate drainage installed along the perimeter or ground falling away from the building
- adjacent surface finishes which do not promote splashing.

Admixtures may be required to enhance performance.

### Resistance to sulfate attack

To prevent sulfate attack, the wall construction should restrict moisture from entering into the background and having a detrimental effect on the performance of the render.

When detailing between the render and exposed brickwork, it is advisable to use appropriate materials resistant to, or without sources of, sulfate.

### Render onto board backgrounds <sup>6.11.8</sup>

**Render onto board backgrounds shall be suitable for the intended use and detailed to provide satisfactory performance. Issues to be taken into account include:**

- |  |                       |
|--|-----------------------|
| a) provision of a system manual                    | d) weather resistance |
| b) compatibility between the render and background | e) movement joints    |
| c) fixing back to the structure                    | f) board backgrounds. |

### Provision of a system manual

Where render is applied to a board background, the render manufacturer should clearly define the system in a manual, including:

- materials and components
- common details
- design guidance
- installation guidance.

The system should be used in full accordance with the manufacturer's guidance and recommendations.

### Compatibility between the render and background

The background should be appropriate for its intended use. Issues to be taken into account include:

- compatibility between the board and render
- durability classification of the board and its suitability for use in exterior conditions, including resistance to weather prior to the render being applied.

Render onto board backgrounds should:

- not be applied where the surface has contamination, dust or loose particles
- consider the effects of solar radiation (colour, orientation and shading)
- be mixed to ensure colour consistency where coloured pigments are specified
- be specified and used with the appropriate ancillary items, such as trims to form corners and returns.

Boards should not be left exposed prior to rendering for longer than is necessary.

### Fixing back to the structure

Board backgrounds should be fixed back to the structure in accordance with the manufacturer's recommendations.

The fixing design should consider:

- wind load
- pull-through resistance
- pull-out strength
- anticipated movement.

Fixing battens and rails should be installed vertically and not block drainage paths. Timber battens should be suitably treated.

### Weather resistance

Timber and steel framed backing walls should have a minimum 25mm cavity.

Cavities to timber framed walls should be drained and vented, and cavities to steel framed walls should be drained.

To reduce the risk of damage from impact, especially at low level, where people have access around balconies and where cradle systems etc. can come into contact with the façade, appropriate precautions such as closer supports should be considered.

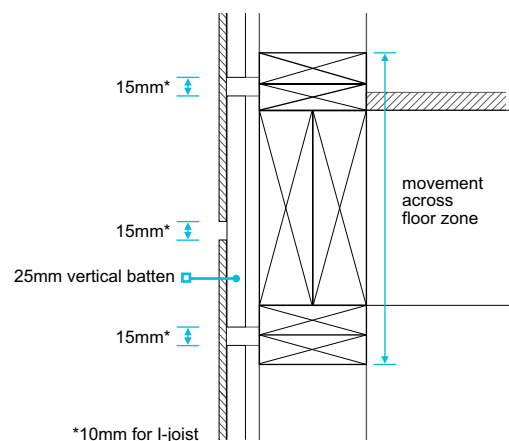
Cavity barriers should be appropriately detailed to ensure satisfactory performance and:

- be provided in accordance with building regulations
- account for movement in the frame
- not block ventilation or drainage paths
- be used in accordance with the manufacturer's recommendations.

### Movement joints

Movement joints should be provided to accommodate movement in timber frame structures. Where board backgrounds are used, movement joints should be:

- formed in accordance with the system manufacturer's recommendations
- continued through the background board
- positioned to accommodate calculated deflection or movement
- provided at floor zones.



### Board backgrounds

Board backgrounds to be rendered should be external grade and recommended for use in the render manufacturer's system manual.

Boards should be set out in accordance with the system manufacturer's recommendations, taking account of possible compression, deflection and alignment of joints in relation to openings in the external wall, such as windows and doors.

The render should have alkali-resistant mesh embedded into the base coat across the whole surface.

Edges of boards should be suitably treated to provide protection from weather during construction and to maintain durability after the render is completed.

### Finishes <sup>6.11.9</sup>

**Finishes shall be to a satisfactory standard. Issues to be taken into account include:**

- a) decorative finishes
- b) appearance.

#### Decorative finishes

The choice of decorative finish should take account of :

- the exposure zone
- background movement potential.

Scraped or textured finishes can reduce the risk of crazing and can break up the drainage path of rain-water as it runs down the face of the wall.

Wet dash and dry dash finishes should have an aggregate size generally between 6mm and 14mm. Dry dash should be applied to the final coat before it has fully cured.

#### Appearance

Render on external walls should be reasonably consistent in texture, finish, colour and line. Clause 9.1.2b provides further guidance on tolerances to render finishes.

Consideration should be given to detailing that will avoid obvious staining (e.g. the positioning of discharge pipes).

Completed render should be protected from damage that could be caused by construction activities.

Render may not be resistant to staining and may require periodic maintenance such as cleaning.

# Flat roofs and balconies

## CHAPTER 7.1

This chapter gives guidance on meeting the Technical Requirements for flat roofs and balconies.

Waterproofing using profile sheet is outside the scope of this chapter.

7.1.1	Compliance	01
7.1.2	Provision of information	01
7.1.3	Flat roof and balcony design	01
7.1.4	Timber and timber decks	02
7.1.5	Profiled metal decks	04
7.1.6	Concrete decks	04
7.1.7	Thermal insulation and vapour control	05
7.1.8	Waterproofing and surface treatments	05
7.1.9	Green and proprietary roofs	07
7.1.10	Detailing of flat roofs	09
7.1.11	Accessible thresholds	11
7.1.12	Drainage	12
7.1.13	Guarding to balconies	14



Raising Standards. Protecting Homeowners

### Definitions for this chapter

For the purposes of this chapter, the following definitions apply:

<b>Flat roof</b>	A roof with a maximum slope of 10° from the horizontal. Systems may be used at a greater pitch where they meet the requirements of this chapter, and materials are adequately held in place.
<b>Deck</b>	The structural substrate of the flat roof.
<b>Decking</b>	The upper trafficked surface of the balcony.
<b>Warm roof</b>	Insulated above the deck.
<b>Cold roof</b>	Insulated below the deck.
<b>Inverted warm roof</b>	Insulated above the waterproofing.
<b>Intensive green roof</b>	Vegetation contained within soil.
<b>Extensive green roof</b>	Vegetation contained in the sedum.

### Compliance <sup>7.1.1</sup>

Also see: Chapter 2.1

#### Flat roofs and balconies shall comply with the Technical Requirements.

Flat roofs and balconies which comply with the guidance in this chapter will generally be acceptable to NHBC.

Other sources of information include:

- BS 6229 'Flat roofs with continuously supported coverings. Code of practice'
- National Federation of Roofing Contractors (NFRC)
- Mastic Asphalt Council (MAC)
- Single Ply Roofing Association (SPRA)
- Liquid Roofing and Waterproofing Association (LRWA).

Where the flat roof or balcony is a terrace above another home, it should provide satisfactory acoustic performance in accordance with relevant building regulations.

### Provision of information <sup>7.1.2</sup>

#### Designs and specifications shall be produced in a clearly understandable format, include all relevant information and be distributed to all appropriate personnel.

Design and specification information should be issued to site supervisors, relevant specialist subcontractors and suppliers, and include the following information:

- Extent and direction of falls, and position of rainwater outlets.
- Sections through the construction, indicating how falls are formed and ventilation is provided.
- Size, specification and position of the components, including treatments for durability and the position of the vapour control layer, insulation and waterproofing layers.
- Details at critical junctions.
- Details of fixings and fixing methods, including those for insulation and surfacing.
- Specification for intensive, or extensive green roofs.
- Details and fixing methods of balcony support and guarding components.

### Flat roof and balcony design <sup>7.1.3</sup>

#### Flat roofs and balconies shall support and transmit loads safely to the structure.

The structural design of flat roofs and balconies should:

- be produced by an engineer in accordance with Technical Requirement R5, and be in accordance with BS EN 1991-1-1, BS EN 1991-1-3 and BS EN 1991-1-4
- resist wind uplift by either being of sufficient self-weight or by being anchored to the main structure – where required, holding-down straps should be provided at a maximum spacing of 2m
- have adequate provision for the additional loads where a flat roof is to act as a roof terrace, roof garden or car parking area
- have adequate provision for movement in larger roofs, particularly where the span of the roof deck changes, e.g. in L-shaped buildings; joints should be continuous through the vertical upstands, walls and edges of the building
- include support steelwork and purlins which are square, true and free from twists or sagging.

Where joists and concrete roof elements are used to provide lateral restraint, they should:

- have a minimum bearing of 90mm, or
- have restraint straps at 2m centres (maximum) where joists or concrete beams are parallel to walls.

**Timber and timber decks** <sup>7.1.4</sup>

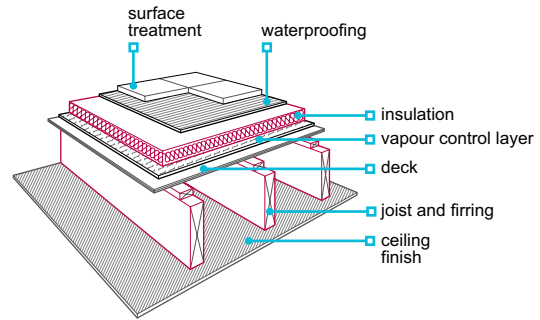
**Timber flat roofs and balconies shall be of adequate strength and durability, and be installed to form a satisfactory substrate for the waterproofing system. Issues to be taken into account include:**

- a) structure and durability
- b) joist hangers, straps and strutting
- c) installing timber substrates.

**Structure and durability**

Timber should be:

- checked for conformity with the design upon delivery
- rejected where excessively wet, damaged or not of a suitable quality or shape
- stored under cover to prevent wetting
- preservative treated or naturally durable, in accordance with Chapter 3.3 'Timber preservation (natural solid timber)'
- retreated along the cut edges with a coloured preservative, where preservative treated timber has been cut.



Timber decks should:

- be in accordance BS EN 1995-1-1 or appropriate load/span tables published by TRADA in support of building regulations
- be from regularised timber, dry graded to BS 4978 and marked 'DRY' or 'KD' where softwood is used internally
- have I-joists or metal web joists specified in accordance with the manufacturer's recommendations and not used where any part of the joist is exposed to external conditions
- have joists which are sized and spaced in accordance with the design and at a maximum of 600mm centres
- be temporarily covered to prevent wetting, unless the waterproofing is to be installed immediately
- be level and, where necessary, using hard packing such as tiles or slates bedded in mortar to adjust joists (loose or soft packing, including timber, should not be used)
- formed with one of the materials listed in Table 1.

**Table 1:** Materials used for decking

Material	Thickness of deck (mm)	
	450mm joist centres	600mm joist centres
Plywood to BS EN 636, Class 3	15	18
Oriented strand board, type OSB3	15	18
Pretreated timber planking, tongue and grooved (close boarded timber) Maximum board width 100mm	19	19

Structural elements of balconies should have a service life of at least 60 years.

Timber in balconies should be limited to elements which are supported by materials other than timber. Timber should not be used for:

- gallows brackets supporting a balcony
- posts or columns supporting a balcony
- guardrails or their support
- cantilevered decks or joists
- infill joists.

Decking boards should be specified and fixed in accordance with:

- guidance from the Timber Decking Association, or
- an engineer's design, in accordance with Technical Requirement R5.

### Joist hangers, straps and strutting

Masonry carrying joist hangers should be level and at the correct height.

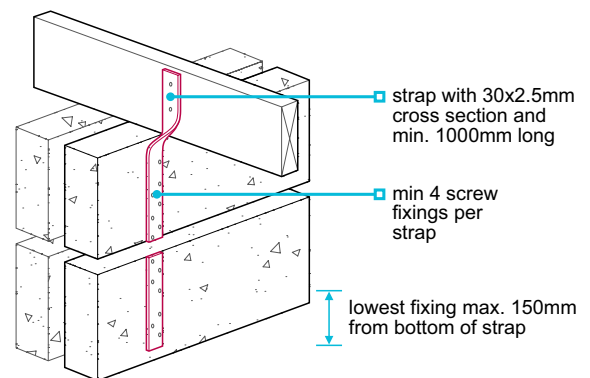
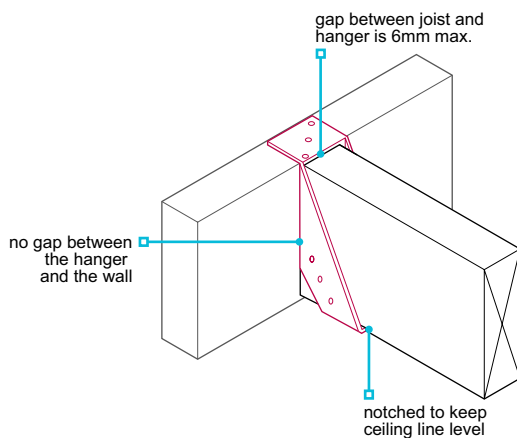
Mild steel straps and fixings should be protected against corrosion in accordance with BS EN 845-1.

Joist hangers should be:

- in accordance with BS EN 845
- the correct size for the timber joist or trimmer
- fixed in accordance with the design.

Where holding-down straps are required to prevent the roof from lifting from the supporting structure, they should be:

- spaced at a maximum of 2m centres
- fixed with a minimum of four hardened nails 4mm in diameter x 75mm long, or No 12. wood screws x 50mm long, into plugs (where fixed to masonry)
- fixed with the lowest fixing secured within 150mm of the bottom of the vertical strap
- 30mm x 2.5mm and 1m long
- predrilled for fixings.



Strutting should be provided to prevent excessive movement, and::

- be either herringbone type (timber 38mm x 38mm), solid blocking (38mm thick timber x 0.75 depth of joist) or proprietary steel strutting
- not prevent cross ventilation in cold deck roofs.

**Table 2:** Spacing for strutting

Joist span (m)	Rows of strutting
Up to 2.5	None needed
2.5-4.5	One (at centre of span)
Over 4.5	Equally spaced along the span at maximum 2.5m centres

### Installing timber substrates

When installing timber substrates:

- conditions should be dry, and materials protected from wetting until the roof is complete
- the area of deck installed should be of a size which can be quickly covered in the event of rain
- joints in sheet materials which are precovered or coated should be sealed immediately after fixing
- materials that have been damaged or adversely affected by moisture should be discarded.

Plywood and oriented strand board should:

- have tongued and grooved boards installed with the long edge at right angles to the joists, and short edges supported on a joist or noggings
- have a maximum movement gap between boards of 3mm for square edge boards
- have a minimum movement gap of 10mm where boards abut a rigid upstand
- be supported on noggings where the edges of boards situated along the roof perimeter do not coincide with joists
- be fixed at a maximum of 100mm centres (unless the design specifies closer)
- be fixed with flat-headed ring shank nails (50mm long x 3mm for plywood, 3mm x 2.5 x board thickness for OSB).

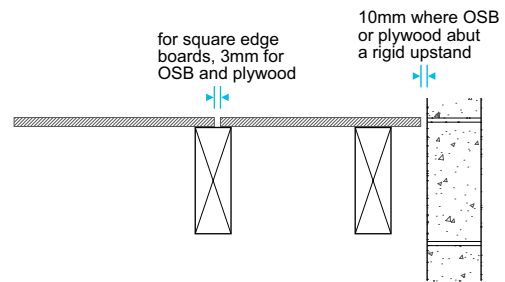


OSB should be:

- installed over supports in the direction indicated on the boards, with the stronger axis installed at right angles to the supporting joists
- fixed a minimum of 9mm from the edge of the board.

Softwood tongued and grooved boarding should be:

- closely clamped together with end joints staggered
- fixed with two ring shank nails to each joist or firring, with nail heads punched below the timber surface.

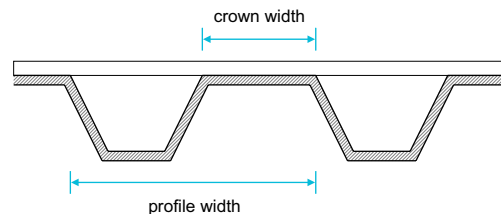
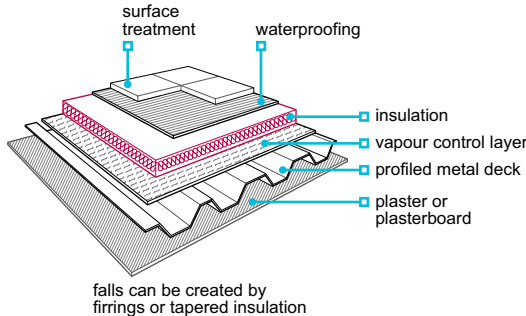


### Profiled metal decks <sup>7.1.5</sup>

**Profiled metal flat roofs and balconies shall form a satisfactory substrate for the waterproofing system.**

Profiled metal flat roofs should:

- be constructed to ensure they achieve the required strength and durability, and be checked for conformity with the design upon delivery
- be suitably stored to prevent damage
- comply with the manufacturer's load and span tables and the relevant applied safety factor
- resist loads in accordance with BS EN 1991-1-4 and be fixed in accordance with the manufacturer's instructions
- be galvanised steel to BS EN 10147 or aluminium to BS EN 485-2 and used in accordance with BS EN 1993-1-3
- have a crown which is a minimum of 50% of the profile width (for bonded systems)
- have a crown which is a minimum of 45% of the profile width (for mechanically fixed systems)
- be side stitched to ensure it performs as a continuous plane layer (unless the manufacturer recommends otherwise)
- be fixed and installed in accordance with the design and variations approved by the designer
- be adequately protected from construction loads
- be of suitable quality and finish before the waterproofing and insulation system is installed.



### Concrete decks <sup>7.1.6</sup>

**Concrete flat roofs and balconies shall form a satisfactory substrate for the waterproofing system.**

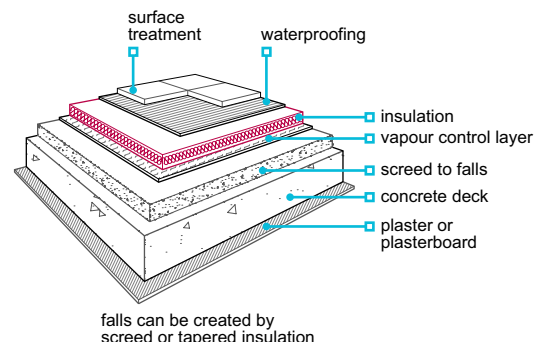
Concrete flat roofs should be constructed to ensure they achieve the required design, strength and durability, and be in accordance with BS EN 1992-1-1 and Chapter 3.1 'Concrete and its reinforcement'.

In-situ reinforced concrete decks should:

- be formed using a mix which has low shrinkage characteristics
- have accurately constructed and suitably supported formwork
- be protected until adequately cured and dried (permanent waterproofing should not be installed until the deck has fully dried).

Precast concrete decks should:

- be installed on an even and true supporting structure
- have a minimum 90mm bearing (unless the design specifies a smaller dimension)
- have allowance for continuity or anti-crack reinforcement
- have allowance for movement approximately every 15m and at abutments
- be installed to provide an even surface
- be grouted, as specified in the design.



### Thermal insulation and vapour control <sup>7.1.7</sup>

Also see: BRE Report 'Thermal insulation: avoiding risks' and BS 5250

**Thermal insulation, vapour control and ventilation shall ensure satisfactory performance, and prevent the formation of condensation which could adversely affect the construction.**

Insulation should be:

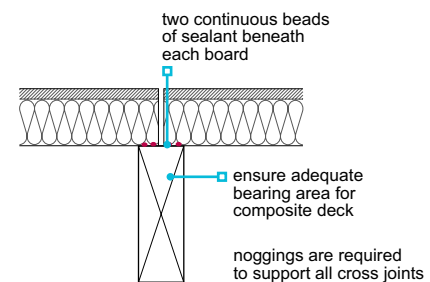
- bonded or mechanically fixed in accordance with the manufacturer's recommendations; where mechanically fixed, it should be installed using fixings of sufficient length to ensure adequate penetration into the supporting structure
- kept dry and installed in quantities which can be quickly covered if it rains (to aid bonding and to avoid trapping moisture).

Cold flat roofs are difficult to detail correctly but, where used, they should be in accordance with BS 5250 and have:

- an effective vapour control layer at ceiling level
- an unobstructed 50mm ventilation space above the insulation
- adequate cross ventilation (openings at both ends of each joist void).

Composite decks should:

- have two beads of sealant along each board joint at the foil underface (to maintain the integrity of the vapour control layer).



Insulation for inverted roofs should be:

- extruded polystyrene (XPS), extruded polystyrene with a cementitious surface or suitably assessed in accordance with Technical Requirement R3
- suitable for external use
- suitable for the weight of the ballast and able to withstand anticipated traffic
- protected by a geo-textile layer to prevent fines from reaching the membrane surface.

Vapour control layers should be provided to warm roofs, and:

- include at least one layer of bitumen roofing membrane (S2P3) below the insulation, fully bonded or mechanically fixed to the structural deck as appropriate, or a suitable self-adhesive or torch-on membrane.
- sealed at laps to the waterproofing, at the perimeter and at each penetration, e.g. at outlets and pipes (where the roof is a single-ply system, the vapour control is generally not sealed to the waterproofing).
- where a mechanically fixed system is used, the vapour control layer should consist of suitable polyethylene sheet sealed at all laps.

### Waterproofing and surface treatments <sup>7.1.8</sup>

**Flat roofs, and balconies forming roofs, shall adequately resist the passage of water to the inside of the building. Issues to be taken into account include:**

- installation of waterproofing
- waterproofing systems
- surface treatments.

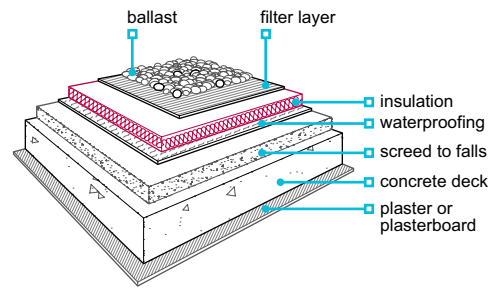
#### Installation of waterproofing

Prior to the waterproofing being installed:

- the structure and receiving surface should be checked and approved by the waterproofing contractor
- the manufacturer's recommendations for preparation, including priming upstands, roof outlets, etc. should be followed to achieve a satisfactory bond with the waterproofing
- the surface should be even and dry and nails should be punched below the surface
- the manufacturer's recommendations for conditioning, and unrolling in advance of laying, should be followed
- concrete and screed surfaces should be adequately dry.

Environmental conditions should be suitable for installing waterproofing. Issues to be taken into account include the following:

- Sheet membranes should not be installed or handled when the air temperature is 5°C or less (unless otherwise agreed with the manufacturer).
- Self-adhesive reinforced bitumen membranes should not be installed below 10°C, and the manufacturer's recommendations should be followed.
- Membranes should not be installed on damp or frosted surfaces or when any rain, sleet or snow is falling.



Waterproofing should be:

- installed in accordance with the design and the manufacturer's recommendations
- installed by a specialist roofing contractor approved by the manufacturer, where a proprietary system is used
- installed by the same contractor who installs the vapour control layer, insulation and surface finish

- checked by the contractor to ensure that the deck and insulation boards are waterproofed at the end of each day, and before inclement weather
- installed so that membrane laps near outlets do not impede drainage
- installed so that successive layers do not trap water.

Inverted roofs should:

- not be used for slopes greater than 10°
- be designed to support the loads, particularly from ballast needed to retain the insulation material

- be ballasted to the depth specified in the design
- be ballasted using paving slabs or minimum 19mm diameter rounded pebbles.

### Waterproofing systems

#### Reinforced bitumen membrane

Reinforced bitumen membrane should be high performance and reinforced with polyester reinforcement, e.g. type 5U, 5B/180, 5E/250 to BS 747 (type 5 reinforced bitumen membranes are colour-coded blue for identification).

**Table 3:** Reinforced bitumen membrane used in warm roof construction

Insulation material	First/preparatory layer	Second layer/underlay	Final layer/cap sheet
Rigid urethane foam (RUF) boards – polyurethane (PU) and polyisocyanurate (PIR).	Type 3G perforated layer (loose laid and lapped, to produce partial bonding).	S2P3	S5P5 with either integral mineral finish or separate solar protection.
		Elastomeric underlay achieving S2P3	Elastomeric capsheet achieving S2P3, mineral surfaced where exposed.
Compressed cork, rock fibre or glass fibre boards, cellular glass slabs, perlite boards or composite products.	S2P3 (fully bonded in accordance with BS 8217).	S2P3	S5P5 with either integral mineral finish or separate solar protection.
		Elastomeric underlay achieving S2P3	Elastomeric capsheet achieving S2P3, mineral surfaced where exposed.

**Table 4:** Reinforced bitumen membrane for an inverted warm roof

Deck material	First/preparatory layer	Second layer/underlay	Final layer/cap sheet
Concrete, or concrete with sand/cement screed.	Type 3G perforated layer (loose laid and lapped, to produce partial bonding).	S2P3	S5P5 with either integral mineral finish or separate solar protection.
		Elastomeric underlay achieving S2P3	Elastomeric capsheet achieving S2P3, mineral surfaced where exposed.

Torching onto insulation boards, except rockwool or perlite, is not acceptable.

Elastomeric (i.e. SBS polymer-modified) bitumen membranes offer increased extensibility and flexibility, especially at low temperatures, and can provide a longer service life.

#### Mastic asphalt

Mastic asphalt should be:

- to BS 6925, type 988 T25, 20mm thick on the flat and installed on black sheathing felt
- (for green roofs) 3 x 10mm layers on horizontal surfaces and 2 x 10mm layers on vertical surfaces, for green roofs.

Polymer modified asphalt should be assessed in accordance with Technical Requirement R3.

### Thermoplastic single-ply membranes

Thermoplastic single-ply membranes, including materials such as PVC (polyvinyl chloride) and TPO (thermoplastic polyolefine) should be:

- either bonded to the insulation, mechanically fixed to the deck or loose-laid, and sealed and ballasted in accordance with the manufacturer's recommendations
- welded at laps using either hot air or a specific solvent
- assessed in accordance with Technical Requirement R3.

### Surface treatments

Surface treatments should be in accordance with Table 5.

**Table 5:** Surface treatments for flat roofs

	Access for maintenance only – roofs up to 10°	Access roof, walkway or terrace deck
Reinforced bitumen membranes	<ul style="list-style-type: none"> <li>■ Mineral surfaced capsheets (e.g. type S5P5).</li> <li>■ Reflective stone chippings<sup>(1)</sup>, bedded in a dressing compound.</li> <li>■ A suitable thickness of washed, rounded 20-40mm shingle ballast laid loose.</li> </ul>	<ul style="list-style-type: none"> <li>■ Precast semi-porous concrete tiles bedded in bitumen or approved adhesive.</li> <li>■ Precast concrete proprietary paving slabs on supports or sand/cement blinding<sup>(2)</sup>.</li> <li>■ Proprietary timber decking systems<sup>(3)</sup>.</li> </ul>
Mastic asphalt	<ul style="list-style-type: none"> <li>■ Reflective stone chippings<sup>(1)</sup>, bedded in a bitumen based compound.</li> <li>■ A solar reflective paint approved by the MAC.</li> </ul>	<ul style="list-style-type: none"> <li>■ Precast semi-porous concrete tiles bedded in bitumen or approved adhesive.</li> <li>■ Precast concrete proprietary paving slabs on supports or sand/cement blinding<sup>(2)</sup>.</li> </ul>
Thermoplastic single-ply membranes	<ul style="list-style-type: none"> <li>■ Supplementary solar reflective coatings or other finishes not required.</li> <li>■ Where laid loose, membranes can be ballasted with a suitable thickness of washed, rounded 20-40mm shingle installed on a non-woven polymeric protection layer.</li> </ul>	<ul style="list-style-type: none"> <li>■ Proprietary flexible, non-slip walkway sheets or tiles, compatible with the membrane product.</li> <li>■ Precast concrete proprietary paving slabs on adjustable supports or suitable non-woven polymeric protection layer.</li> <li>■ Proprietary timber decking systems with bearers set on an additional membrane or suitable non-woven polymeric protection layer.</li> </ul>
Cold applied liquid roofing membranes	<ul style="list-style-type: none"> <li>■ Products generally do not require supplementary solar reflective coatings or other finishes.</li> </ul>	<ul style="list-style-type: none"> <li>■ Proprietary surface treatments compatible with the membrane product.</li> <li>■ Proprietary flexible, non-slip walkway tiles, compatible with the membrane product.</li> <li>■ Precast concrete proprietary paving slabs on supports on a suitable non-woven polymeric protection layer.</li> <li>■ Proprietary timber decking systems with bearers set on additional pads on a suitable non-woven polymeric protection layer.</li> </ul>
Hot melt rubberised bitumen systems	<ul style="list-style-type: none"> <li>■ Use in inverted/buried roof membrane applications or in roof garden/green roofs.</li> <li>■ Must be protected with a substantial reinforced bitumen membrane protection sheet.</li> <li>■ All upstands/details where the membrane becomes exposed need a protective membrane to be applied to prevent UV degradation.</li> </ul>	

#### Notes

- 1 Loose surface finishes should be prevented from being removed by weather and discharged into gutters and drain pipes. Chippings should be a minimum of 12.5mm limestone or white spar, not pea gravel.
- 2 Cement/sand blinding should be installed on two layers of waterproof building paper or two layers of 1000 gauge polyethylene separating membrane. Slabs should be kept back 75mm at perimeters and a 25mm movement gap incorporated for every 9m<sup>2</sup> of paving.
- 3 Timber decking systems should only use compatible preservative treatments. The undersides of the bearers should have large, smooth contact areas, with no sharp edges or corners.

### Green and proprietary roofs <sup>7.1.9</sup>

#### Green roofs and proprietary roofing systems shall be suitable for their intended use.

Green roofs should:

- be clearly defined by the supplier as a complete system
- have supporting data to demonstrate compliance with relevant standards
- include waterproofing suitable for use in the green roof system.

Rainwater outlets should be accessible and have a visible inspection hatch.

Green roof systems that do not comply with the principles of this chapter should be assessed in accordance with Technical Requirement R3.

The complete green roof should be installed by a contractor trained and approved by the system supplier.

Waterproofing for green roofs should be either:

- reinforced bitumen membrane
- mastic asphalt
- single-ply membrane, or
- a liquid applied system.

The system should be installed in accordance with the design and the membrane manufacturer's recommendations.

Before covering:

- the membrane should be visually inspected and electronically tested for waterproofing integrity, faults rectified, and retested before further layers are placed: the results should be made available to NHBC
- any damage to the vapour control layer should be repaired, using a full width section of membrane.

Other issues that should be taken into account when installing green roofs include the:

- provision of root barriers
- height of upstands in relation to soil height and flashings
- protection, reservoir and filter layers
- moisture control of the soil.

**Table 6:** Principles for green roofs

	Intensive	Extensive
<b>Features</b>	<ul style="list-style-type: none"> <li>■ Provides a normal garden environment.</li> <li>■ Uses natural topsoil 150mm deep and 'normal' plants.</li> <li>■ Requires regular 'intensive' maintenance, i.e. similar to a normal garden.</li> <li>■ Requires protection of the waterproofing membrane from possible damage during maintenance of the garden, e.g. from weeding/planting.</li> </ul>	<ul style="list-style-type: none"> <li>■ Requires minimal maintenance, i.e. annual attention.</li> <li>■ A sedum blanket contains the plants.</li> </ul>
<b>Structure</b>	<ul style="list-style-type: none"> <li>■ 20° maximum roof pitch, accounting for full weight of wet soil (generally supported by a concrete deck).</li> </ul>	<ul style="list-style-type: none"> <li>■ 45° maximum roof pitch deck (profiled metal decks may be an alternative to concrete, depending on loadings).</li> </ul>
<b>Drainage falls</b>	<ul style="list-style-type: none"> <li>■ 1:60min.</li> </ul>	
<b>Moisture control</b>	<ul style="list-style-type: none"> <li>■ Irrigation system may be required.</li> <li>■ Can be designed to retain some water in order to maintain the vegetation and to reduce run off.</li> </ul>	
<b>Vapour control layer</b>	<ul style="list-style-type: none"> <li>■ Fully bonded polyester-reinforced RBM (S2P3), a suitable self-adhesive membrane or torch-on membrane.</li> </ul>	
<b>Insulation</b>	<ul style="list-style-type: none"> <li>■ Insulation material should have adequate compressive strength to withstand likely applied loads. Where the insulation is above the weatherproofing, only extruded polystyrene (XPS) should be used.</li> </ul>	
<b>Roots</b>	<ul style="list-style-type: none"> <li>■ A root resistant element, such as a copper foil or Preventol treatment, is required above the waterproofing membrane. Alternatively, an approved root resistant waterproofing membrane can be used.</li> </ul>	
<b>Protection and filter layers</b>	<ul style="list-style-type: none"> <li>■ A protection layer (or board) should be placed above the waterproofing membrane.</li> <li>■ A filter layer should be placed above the reservoir layer.</li> </ul>	<ul style="list-style-type: none"> <li>■ In accordance with the manufacturer's recommendations.</li> </ul>

### Detailing of flat roofs <sup>7.1.10</sup>

**Flat roofs shall be detailed to ensure satisfactory performance.**

The following illustrations are intended as a guide to demonstrate the general principles of flat roof detailing commonly used on warm flat roofs and balconies. Where indicated, the principles are applicable to other types of roof construction. Further information on specific waterproofing systems may be obtained from BS 6229 and BS 8217.

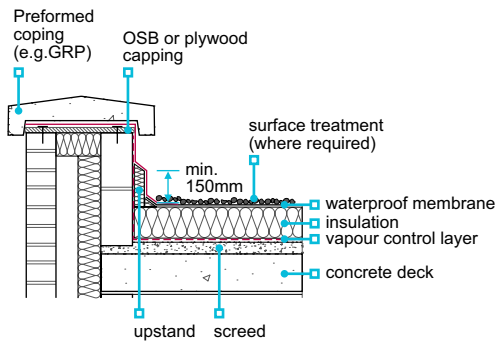
#### Concrete decks

##### Upstands

Upstands may be fixed to the wall.

Upstands should be a minimum of 150mm high.

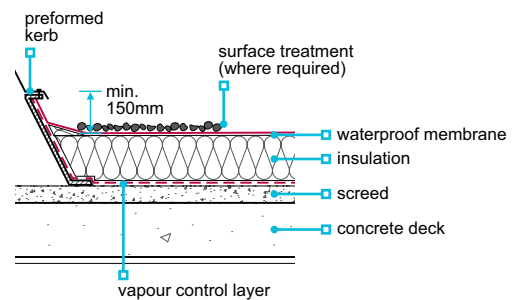
Similar details apply to inverted roofs with concrete decks.



##### Skirting to rooflights or ventilator kerb

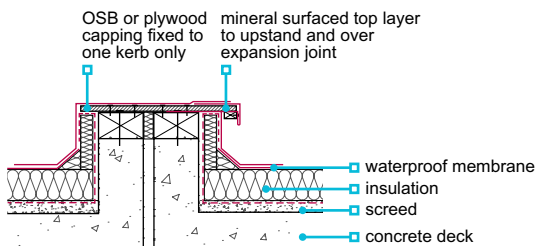
Similar details apply to inverted roofs.

Allow for thickness of ballast to achieve a minimum 150mm upstand.



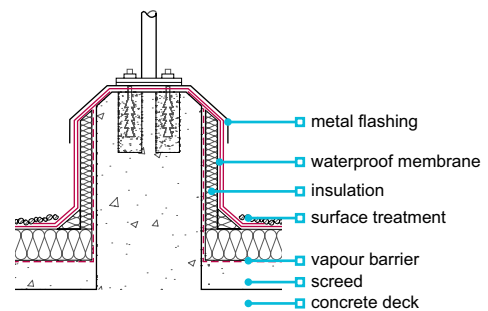
##### Twin-kerb expansion joint

Similar details apply to inverted roofs.



##### Handrail fixing

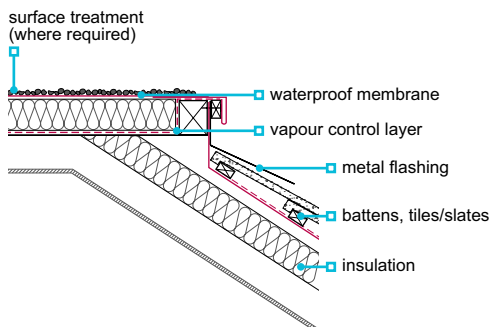
An upstand should be formed in concrete roofs.



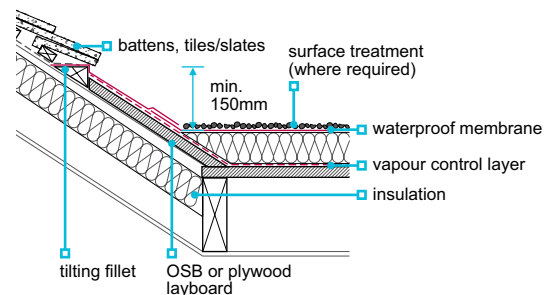
#### Timber decks

##### Mansard edge

Elements should be firmly fixed to prevent peelback in high winds.

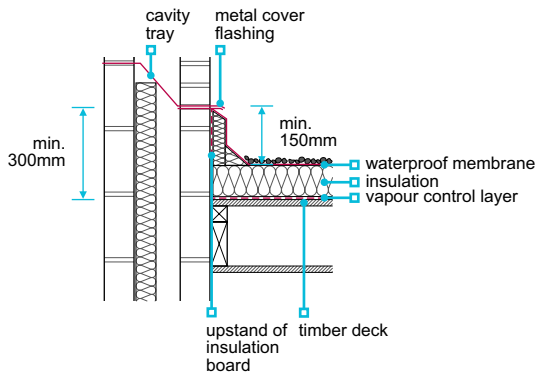


##### Pitched roof abutment



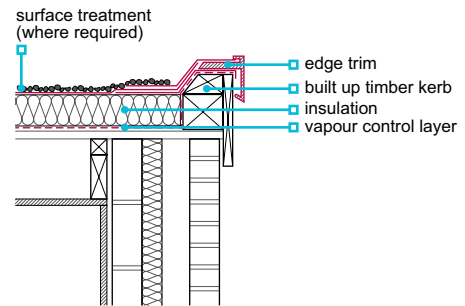
### Independent skirting detail

Upstand should be kept separate from wall, and allow for movement. Upstand should be a minimum of 150mm high. Similar details apply to cold deck timber roofs.



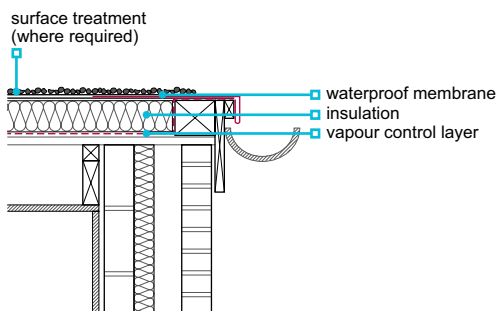
### Verge detail

Similar details apply to inverted decks.



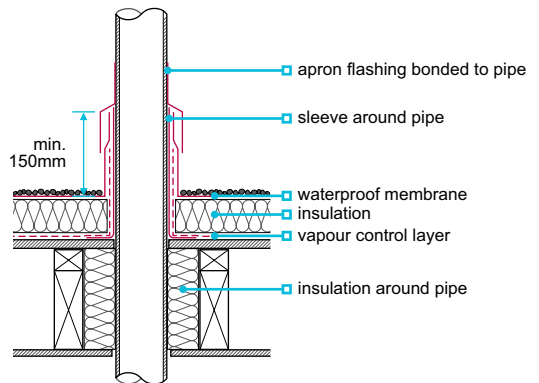
### Welled drip to external gutter

Inverted timber decks should be detailed to avoid insulation being lifted by wind suction and an alternative detail used.



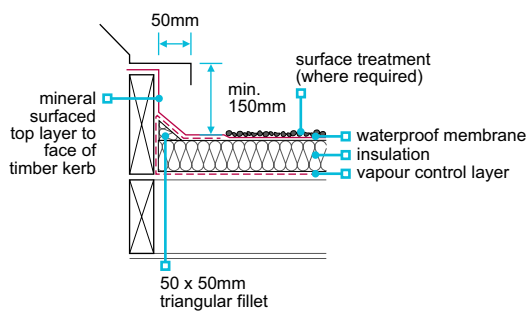
### Pipe passing through roof

Vapour control layer should be bonded to the waterproofing. Detailing of upstand and flashing is similar for all roofs.



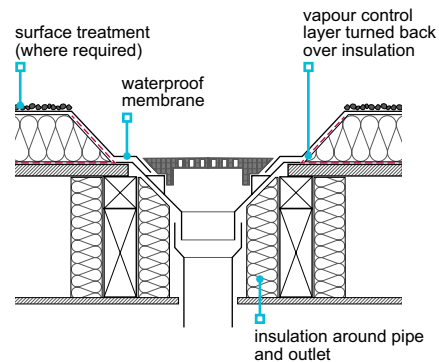
### Upstand to ventilator or rooflight kerb

Similar details apply to cold and inverted roofs. Allow for the thickness of ballast in inverted roofs, to achieve upstand dimensions.



### Rainwater outlet

The opening should be properly trimmed. The outlet should be at the lowest point in roof. Ensure that the outlet is fixed securely to decking to prevent displacement by thermal expansion of rainwater pipe. Similar details apply to concrete roofs.

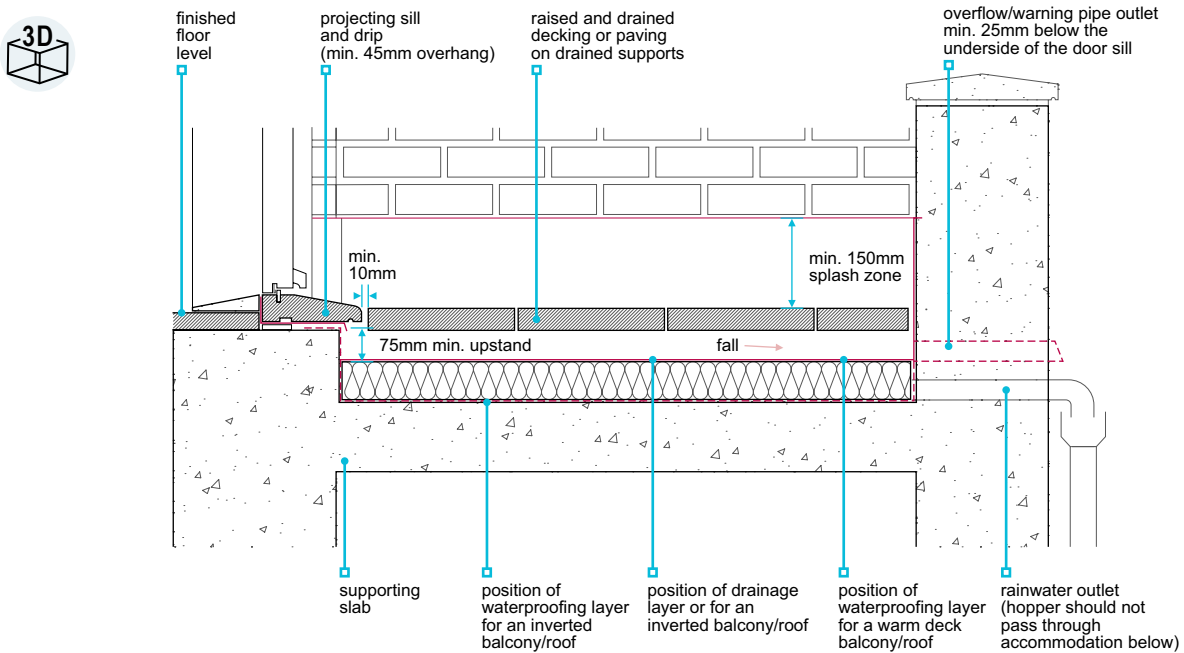


### Accessible thresholds <sup>7.1.11</sup>

Accessible thresholds shall be protected by adequate weatherproofing and drainage.

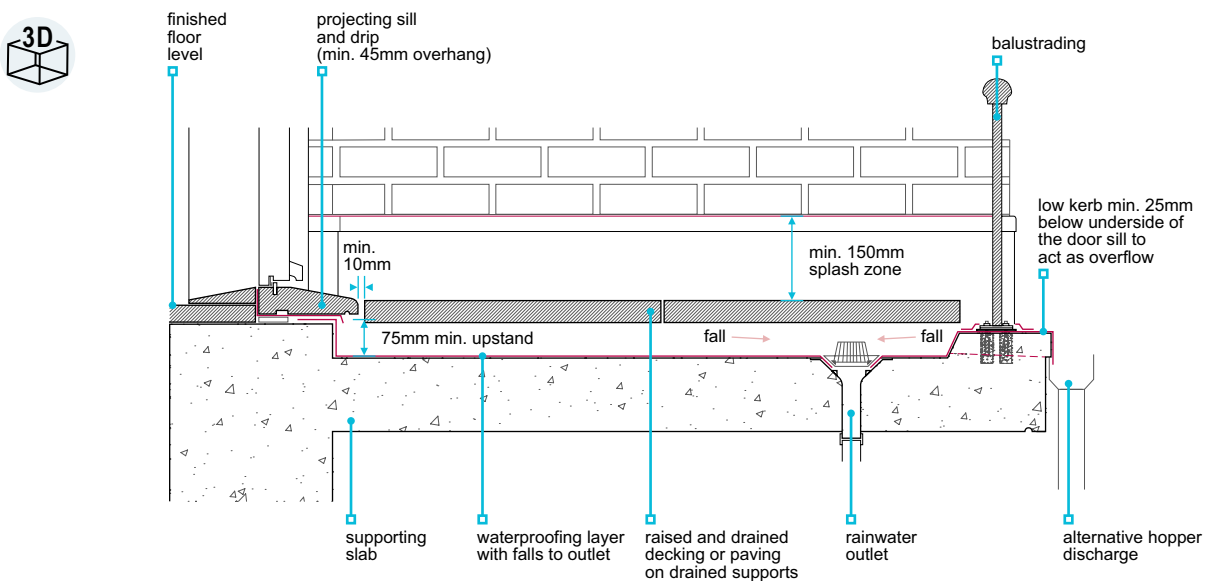
Accessible thresholds should:

- be in accordance with the design – specific fire, thermal and acoustic precautions may be required
- have a maximum 15mm upstand (measured at the door position) at the door threshold; additional sloping transition elements, such as a small internal ramp and external sill, may be provided either side of the upstand; the maximum slope on ramps and sills should be 15 degrees
- have a minimum 45mm projecting sill to shed rainwater away from the interface with the waterproofing layer
- have a 75mm minimum balcony upstand below the underside of the projecting sill, measured from the balcony drainage layer.



Note

The drainage layer is not necessarily the waterproofing layer (i.e. the top of the insulation of an inverted roof should be considered as the drainage layer).





Waterproofing layers should:

- prevent ponding and associated stagnant water
- generally fall a minimum of 1:80 away from the building to the rainwater outlet(s)
- be subject to specific third-party assessment where falls are zero degrees
- be designed to ensure that where falls are towards or parallel to the building, blockage of the outlet(s) cannot cause flooding to the building
- be fully protected from direct trafficking
- be capable of withstanding point loads from supports to decking or paving
- be UV resistant or fully protected from daylight.

Drainage arrangements should be effective and have a suitable overflow. The building should not flood where an outlet or downpipe is blocked. This can be achieved by using:

- at least one outlet and an overflow with the capacity of the outlet
- at least one outlet chute and hopper (sized to serve both the discharge and overflow capacities)
- two outlets connected to independent downpipes, or
- setting the balcony kerb a minimum of 25mm below the door threshold.

Outlets beneath decking or paving should be clearly identifiable and accessible for maintenance.

To ensure adequate drainage:

- gaps should be provided between decking and paving at balcony perimeters
- minimum 10mm gaps should be provided between individual units of decking or paving and the threshold sill, perimeter walls and kerbs
- spacers and supports which raise decking or paving should not obstruct the flow of rainwater to outlet(s).

A splash barrier should be provided:

- to ensure water does not reach any part of the wall that could be adversely affected by the presence of moisture
- to a minimum of 150mm above the decking or paving
- using an impervious wall finish or cladding, or extending the waterproofing layer to form an upstand with cover flashings and cavity trays.

### Drainage 7.1.12

**Flat roofs and balconies shall have adequate and effective rainwater drainage to a suitable outfall. Issues to be taken into account include:**

- a) falls
- b) outlets.

The principles for drainage given in Chapter 7.2 'Pitched roofs' are applicable to flat roofs and balconies.

Rainwater disposal from roofs and balconies 6m<sup>2</sup> or less in area should be considered. Where run-off may cause damage or staining to a façade, or damage to landscaping, then rainwater gutters and downpipes should be provided. The cumulative effect of water discharging from multiple balconies in vertical alignment should be taken into account.

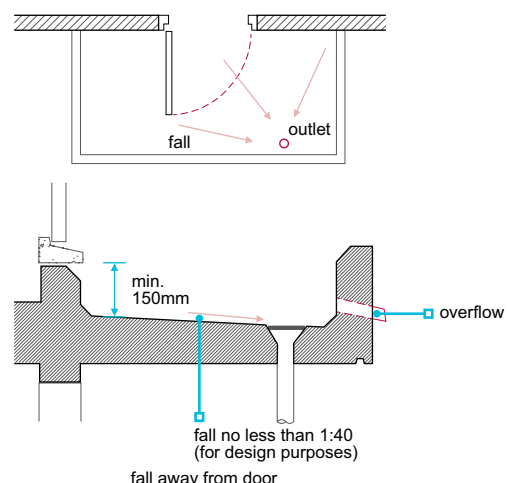
Open slatted balcony decking should drain away from the home.

### Falls

Flat roofs and balconies should:

- be designed with a fall no shallower than 1:40 to ensure a finished fall of no less than 1:80, unless a detailed analysis which includes overall and local deflection is used as justification
- have a minimum finished fall of 1:80 (green roofs 1:60), unless it has a metal sheet covering
- account for deflection in the structural design where falls are achieved using screeds (particularly on large roofs).

Where decking or paving is installed above the waterproofing and is less than 150mm below the sill, it should be of a type and design that prevents a build-up of standing water.



Where tapered insulation is used:

- drainage should be designed by the insulation manufacturer, with falls of no less than 1:60
- construction should comply with the design and manufacturer's recommendations
- the sequence of installation should ensure that boards are waterproofed and the roof sealed at the end of each day, or before the arrival of inclement weather
- it should be installed directly onto the vapour control layer, with the primary waterproofing above
- cross falls should be formed with mitred joints
- successive roof layers should be installed with a minimum of delay, to avoid trapping water during construction.

### Metal sheet roofs

Flat roofs with metal sheet roof coverings should be designed with a fall of no less than 1:30 to ensure a finished fall of no less than 1:60.

### Concrete roofs

Concrete roofs can be finished with sand/cement screed topping set to achieve the falls. Screed finishes should be:

- free from ridges and indentations
- finished with a wooden float to provide a smooth, even surface for the vapour control layer and waterproof finish
- installed by specialist contractors where a lightweight finish is used, and have a topping of 1:6 (cement:sand), 13mm thick
- to the minimum thickness in Table 7 where a cement/sand screed, 1:4 (cement:sand) is used
- suitably dry and primed to receive the waterproofing system.

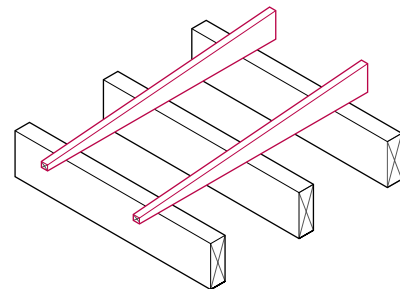
**Table 7:** Minimum screed thicknesses

Location of screed	Nominal thickness (mm)
Bonded monolithically to in-situ or precast concrete	40 (25 minimum.)
Unbonded (on separating layer)	70 (50 minimum.)

### Timber roofs

Furring pieces should be:

- used to form falls, unless the design specifies a sloping joist or ceiling
- of the sizes given in Table 8 where installed across the joists.



**Table 8:** Size of furring pieces used to form cross falls

Joist centres (mm)	Minimum width (mm)	Minimum depth (mm)
400 or 450	38	38
600	38	50

### Rainwater outlets

Rainwater outlets should:

- be of the size and number required to deal with the expected rainfall intensity in accordance with BS EN 12056-3
- be recessed to facilitate the free flow of water
- be accessible for maintenance.

Where a flat roof or balcony has an upstand on all sides, drainage should consist of either two outlets or one outlet plus an overflow. The overflow should be:

- provided through parapet walls or perimeter upstands
- sized and positioned to prevent water from entering the building
- of higher capacity than the combined capacity of the other outlet(s).

**Guarding to balconies** 7.1.13*Also see: Chapter 6.1*

**Balconies, and flat roofs to which persons have regular access other than for maintenance, shall be adequately guarded to minimise the risk of falling. Issues to be taken into account include:**

- a) guarding
- b) stability of guarding
- c) strength and movement of masonry balcony walls
- d) durability and fixing of balustrading and guard rails
- e) access for maintenance.

**Guarding**

Guarding should:

- not be easily climbed
- be to an adequate height
- be toughened glass, laminated glass or glass blocks where glazed balustrading is used
- not be fixed through the waterproofing unless suitable precautions are taken.

**Stability of guarding**

Guarding, including parapet walls, and balustrading used as guarding, should be designed in accordance with BS EN 1991-1-1 to resist horizontal loading and as required by the building regulations. Particular care is needed when the design incorporates balustrading fixed to parapet walls to ensure stability and prevent overturning. End fixings or returns may be needed to ensure stability.

In balcony walls (especially long balconies) the structural stability should be checked, as the DPC at the base of the wall can create a slip plane that can seriously limit the ability of the wall to resist horizontal forces. In such cases, it may be necessary to incorporate a ring beam or other support to ensure stability.

**Strength and movement of masonry balcony walls**

Masonry balcony walls should be built in accordance with Chapter 6.1 'External masonry walls'. In particular:

- walls should incorporate strengthening as required by the design
- movement joints should be provided in accordance with the design
- copings should be firmly fixed.

**Durability and fixing of balustrading and guard rails**

Balustrading and guard rails should be of adequate durability and fixed securely. Also see Clause 7.1.4(a).

**Access for maintenance**

Provision should be made for safe future access to flat roofs for the purposes of maintenance.

## Pitched roofs

### CHAPTER 7.2

This chapter gives guidance on meeting the Technical Requirements for pitched roofs, including:

- coverings
- vertical tiling
- fixings
- ventilation
- weatherproofing.

7.2.1	Compliance	01
7.2.2	Provision of information	01
7.2.3	Design of pitched roofs	01
7.2.4	Protection of trusses	03
7.2.5	Durability	04
7.2.6	Wall plates	04
7.2.7	Joints and connections	05
7.2.8	Restraint	06
7.2.9	Bracing for trussed rafter roofs	07
7.2.10	Strutting for attic trusses and cut roofs that form a floor	09
7.2.11	Support for equipment	09
7.2.12	Access	09
7.2.13	Dormer construction	09
7.2.14	Underlay and sarking	10
7.2.15	Ventilation, vapour control and insulation	11
7.2.16	Firestopping and cavity barriers	13
7.2.17	Battens	14
7.2.18	Roof coverings	14
7.2.19	Fixing tiles and slates	15
7.2.20	Weathering details	18
7.2.21	Valleys and hidden gutters	20
7.2.22	Drainage	21
7.2.23	Fascias and trim	21



Raising Standards. Protecting Homeowners

### Compliance <sup>7.2.1</sup>

*Also see: Chapter 2.1*

#### **Pitched roof structures and coverings shall comply with the Technical Requirements.**

Pitched roofs that comply with the guidance in this chapter will generally be acceptable.

Roofs with a tile or slate covering should be in accordance with BS 5534.

### Provision of information <sup>7.2.2</sup>

#### **Designs and specifications shall be produced in a clearly understandable format, include all relevant information and be distributed to the appropriate personnel.**

Designs and specifications should be issued to site supervisors, relevant specialist subcontractors and suppliers, and include the following information:

- The layout of trusses and associated items.
- Details of mono-pitch, lean-to roofs and roof intersections (i.e. hips and valleys).
- Details of girder trusses, multiple trusses and diminishing trusses, including how they are to be fixed together and supported on truss shoes, layboards or similar.
- Details of bracing requirements.
- Details of supports for equipment in the roof space.
- The type and position of vapour control layers.
- Details of restraint/holding-down strapping, including coatings and fixings.
- The position and thickness of insulation.
- The means of providing eaves ventilation.
- Details of firestopping at separating wall and boxed eaves.
- Details of coverings and fixings, including number and type.
- Details of flashing details at abutments, chimneys, etc.
- Details of trimming around chimneys, access hatches, etc.

For trusses, the design should be provided to the manufacturer in accordance with PD 6693-1, which includes:

- usage, height and location of building, referencing any unusual wind conditions
- rafter profile, referencing camber where required
- spacing, span and pitches
- method of support and position of supports
- type and weight of coverings, including sarking, insulation and ceiling materials
- eaves overhang and other eaves details
- size and approximate position of water tanks or other equipment to be supported
- positions and dimensions of hatches, chimneys and other openings
- type of preservative treatment, where required
- special timber sizes, where required to match existing construction.

### Design of pitched roofs <sup>7.2.3</sup>

*Also see: TRADA Eurocode 5 span tables (3rd edition) and BS 8103*

#### **The sizing and spacing of members shall ensure structural stability and provide restraint to the structure without undue movement or distortion. Issues to be taken into account include:**

- a) trussed rafter roofs
- b) traditional cut roofs.

The design of pitched roofs should:

- have dead and imposed loads calculated in accordance with BS EN 1991-1-1, BS EN 1991-1-3 and BS EN 1991-1-4
- be in accordance with PD 6693-1, and Technical Requirement R5, where appropriate
- be appropriate for the location, accounting for exposure and wind uplift
- ensure that the structure is coherent and that all forces are resolved
- ensure stability with the complete structure, including the connections and compatibility with the supporting structure and adjacent elements
- where trussed rafters and a cut roof are combined, the designer should provide details of the complete roof (particular care is needed in such circumstances).

Roofs should be designed by an engineer in accordance with Technical Requirement R5 where:

- the roof is not a basic pitched roof
- hips, valleys or other special features are included in a trussed rafter roof
- the spans, sizes, spacing or strength classes of the timber are outside the scope of authoritative tables
- trussed rafters support traditional cut roof members, or
- it is a proprietary system (designs supplied by manufacturers will generally be acceptable).

Structural timber should be of a suitable grade and specified according to the strength classes in BS EN 338, e.g. C16, C24 or TR26. When using the BS 4978 grading rules:

- the timber specification should be in accordance with BS EN 1912, or the timber species and strength class identified
- the timber should be marked accordingly.

### Trussed rafter roofs

Trussed rafters should be:

- installed in accordance with the design, and the structure or spacing should not be altered without prior consent from the designer
- fixed to the wall in accordance with the design (e.g. using double skew nailing or truss clips)
- vertical and suitably located (where necessary, temporary bracing should be used to maintain spacing and to keep trusses vertical)
- evenly spaced at maximum 600mm centres.

Where the maximum 600mm spacing cannot be achieved, e.g. to accommodate hatch openings or chimneys, spacing may be increased to a maximum of twice the nominal spacing, provided that the spacing  $X$  is less than, or equal to,  $2A-B$  where:

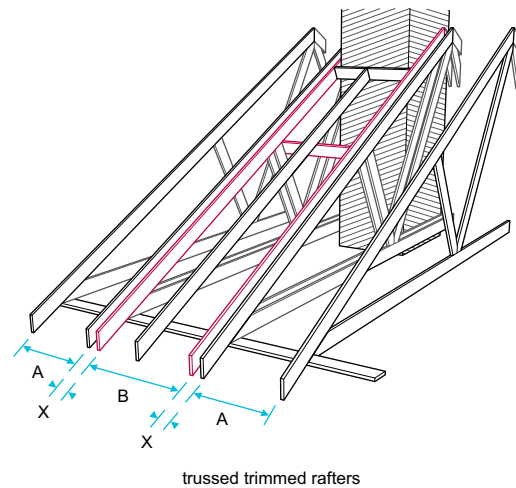
- $X$  = distance between centres of trussed trimmed rafters and the adjacent trussed rafter
- $A$  = design spacing of trussed rafters
- $B$  = nominal width of opening.

Where multiple and reinforcing timbers to simple or multiple trussed rafters are used, they should be:

- designed to be permanently fastened together
- either fixed together during manufacture, or fully detailed drawings and specifications showing the fixing method should be supplied.

Hipped roofs constructed with trussed rafters typically require a series of diminishing mono-pitched trusses supported by a girder truss.

The bearing of mono-pitched trusses into shoes should be in accordance with Table 1, unless designed by an engineer in accordance with Technical Requirement R5.



**Table 1:** Bearing length of mono-pitched trusses into shoes

Span	Minimum bearing length	Minimum thickness of trussed rafter
Less than 4m	50mm	35mm
4m or more	75mm	35mm

Ceiling finishes should be fixed according to the spacing of the support members and the thickness of the sheet.

Plasterboard should be fixed as follows:

- 9.5mm plasterboard should be fixed at a maximum support spacing of 450mm.
- 12.5-15mm plasterboard should be fixed at a maximum support spacing of 600mm.
- Additional members will generally be required to support coverings and finishes where trusses are spaced further apart.

Where the width of a gable ladder exceeds that of the trussed rafter centres, noggings should be used to reduce the span of the roofing tile battens.

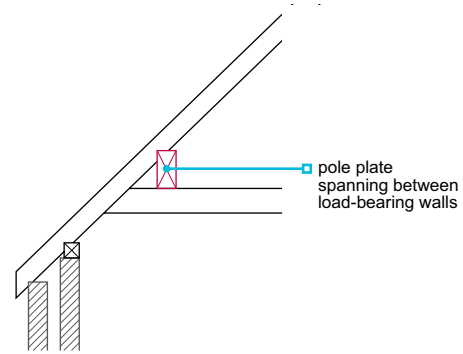
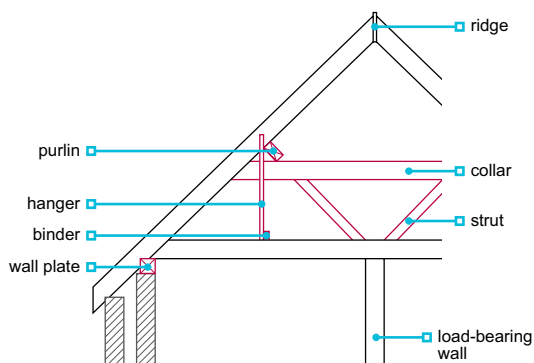
### Traditional cut roofs

For traditional cut roofs:

- the design should specify the details of each structural member and the method of fixing or jointing
- the roof should be in accordance with the design and members accurately located
- members should be fully supported and tied together where necessary, particularly where the roof is not a simple triangle
- temporary support to long span members should be used until framing is complete
- purlins and binders should be built in where necessary
- framing should be completed before coverings are installed.

**Table 2:** Basic timber members

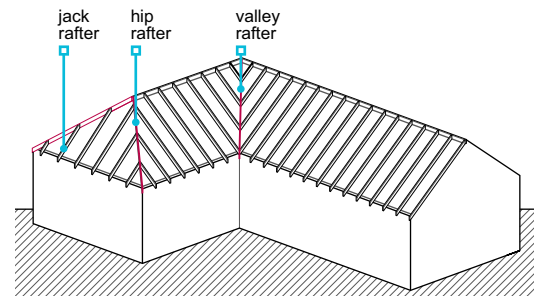
Member	Notes
Valley rafter	Provides support for loads from both sections of the roof and should: <ul style="list-style-type: none"> <li>■ be larger than ordinary rafters to take the additional load</li> <li>■ provide full bearing for the splay cut of jack rafters</li> <li>■ be provided with intermediate support where required.</li> </ul>
Hip rafter	Provides spacing and fixing for jack rafters and should: <ul style="list-style-type: none"> <li>■ have a deeper section than the other rafters to take the top cut of the jack rafters.</li> </ul> Purlins should be mitred at hips and lip cut to accept the bottom of the hip rafter.
Ceiling joist or ties	Provides support for the rafters and should: <ul style="list-style-type: none"> <li>■ stop the walls and roof spreading outwards</li> <li>■ provide support to the ceiling finish and walkways, etc.</li> </ul>
Ridge	Provides fixings and spacing for the tops of the rafters.
Purlin	Provides support to long span rafters to prevent deflection and increase stiffness.
Struts	Provides support to purlins to prevent deflection and to transfer roof loads to the load-bearing structure below.
Collar	Ties the roof together at purlin level.
Ceiling binders and hangers	Provides support to long span ceiling joists.
Pole plates	Similar to purlins, but used where ceiling joists are above wall plate level.



Generally sizes should be as Table 3, unless designed by an engineer in accordance with Technical Requirement R5.

**Table 3:** Typical sizes for timber members

Member	Minimum size
Struts	100mm x 50mm
Valleys	32mm thick
Ridges and hips	Rafter cut + 25mm



### Protection of trusses <sup>7.2.4</sup>

Also see: *International Truss Plate Association Technical Handbook*

#### Trusses shall be protected from damage.

Where the trusses or timber members are damaged, they should be rejected and not repaired. To avoid distortion and to prevent damage, trusses should be:

- protected against weather to prevent the corrosion of truss plates and the deterioration of the timber
- adequately ventilated during storage
- stored clear of the ground
- stored vertically and propped
- stored with level bearers under the joints
- carried upright (fasteners can loosen when carried flat).

**Durability** <sup>7.2.5</sup>

**Timber shall be of suitable durability.**

The following timber members should be naturally durable or treated in accordance with Chapter 3.3 'Timber Preservation (natural solid timber)':

- Porch posts.
- Tiling battens.
- Soffits.
- Bargeboard.
- Fascias and other trim.

Where the roof is to include a fully supported weatherproofing membrane, the following timber components should either be naturally durable or suitably treated:

- Rafters.
- Purlins.
- Ceiling joists.
- Bracing.
- Sarking.
- Wall plates.
- Battens for fixing vertical cladding.

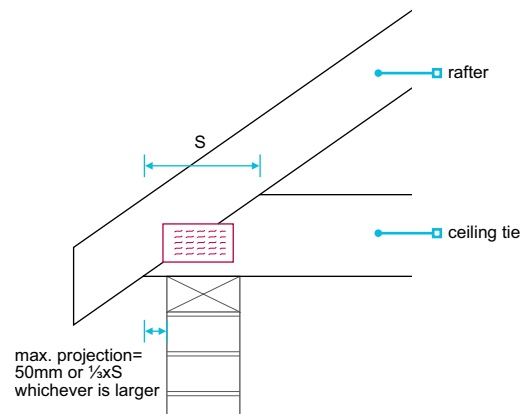
**Wall plates** <sup>7.2.6</sup>

**Wall plates and the roof structure shall be bedded and fixed to distribute and transmit loads, and to prevent uplift.**

Trussed rafter roofs and traditional cut roofs should be supported on timber wall plates. Trussed rafters should only be supported at the junction between the ceiling tie and rafter, unless specifically designed otherwise, e.g. as a cantilever.

Wall plates should be:

- bedded to line and level
- fixed using nails or straps
- a minimum of 3m, extending over at least three joists, rafters or trusses
- joined using half-lapped joints, including at corners
- 38 x 100mm or in accordance with local practice.



Fixings used to connect the roof structure to the wall plate should be specified according to the roof construction and exposure of the site.

Where trussed rafter roofs are not subject to uplift, a minimum of two 4.5mm x 100mm galvanized round wire nails, skew nailed, one on each side of the trussed rafter, or truss clips (fixed in accordance with the manufacturer's instructions) are acceptable.

Where the roof is required to resist uplift, skew nailing is unlikely to provide sufficient strength, and appropriate metal straps should be used. Holding-down straps should be:

- provided according to the geographical location and construction type
- provided where the self-weight of the roof is insufficient against uplift
- provided in accordance with the design
- a minimum cross section of 30mm x 2.5mm and spaced at a maximum of 2m centres (galvanised steel straps are generally acceptable)
- fixed to the wall, or turned into a bed joint.

Fixings for straps should be:

- in accordance with the design, and the lowest fixing should be within 150mm of the bottom of the vertical strap
- of a material or finish which is compatible with the straps
- where into masonry, hardened 4mm x 75mm nails or 50mm long No 12 wood screws (into suitable plugs).



### Joints and connections <sup>7.2.7</sup>

**Joints and connections shall be designed to ensure structural stability without undue movement or distortion.**

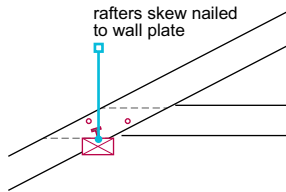
Members should:

- be accurately cut to fit tightly
- not be damaged or split.

The following joints should be used at the main connections of traditional cut roof members:

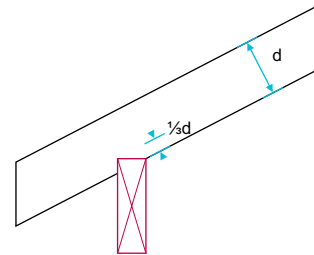
#### Rafters to ceiling joists using a nailed lapped joint

The rafter should be birdsmouthed and skew nailed to the wall plate.



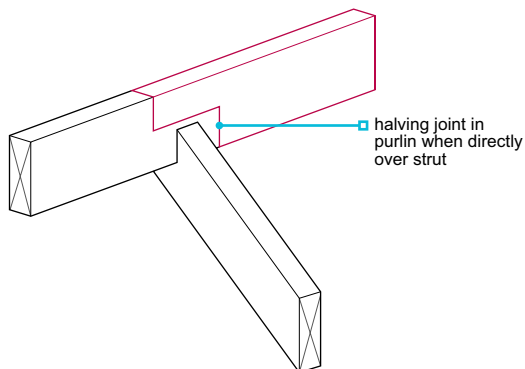
#### Rafter to purlin

A birdsmouth joint should be used generally the purlin is fixed vertically.



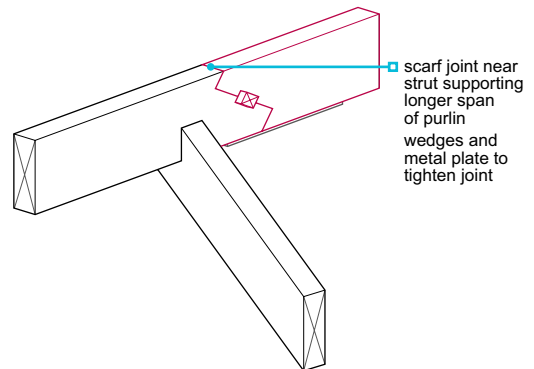
#### Purlin connections

Support should be provided directly under the joint or a scarf joint used. Scarf joints should be made near to a strut so that the joint supports the longer span.



#### Scarf joint

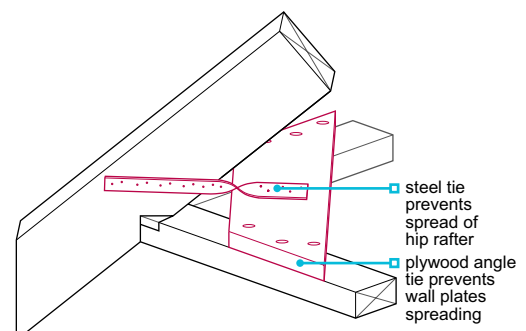
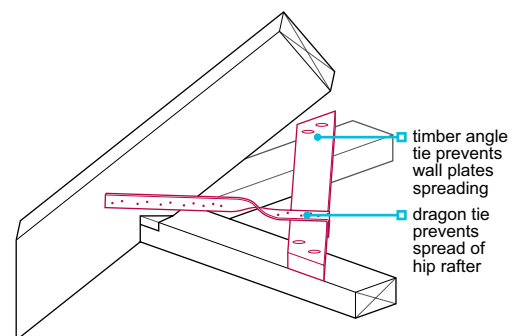
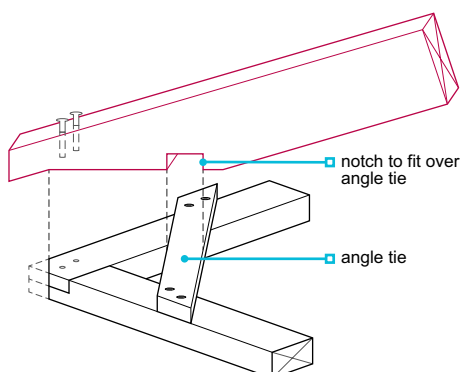
Used to support the long span of the purlin.



#### Hipped roof joints

Angle ties should be used at the corners of hipped roofs to prevent the wall plates from spreading.

Where hip rafters are heavily loaded, e.g. carrying purlins, they should be jointed using dragon ties, or similar, to prevent the hip rafter spreading.



**Restraint** <sup>7.2.8</sup>

*Also see: Chapter 6.1*

**Adequate restraint shall be provided to support the structure, distribute roof loads and prevent wind uplift. Strapping shall be of adequate strength and durability, and fixed using appropriate fixings.**

Restraint straps, or a restraining form of gable ladder, should be used where required to provide stability to walls, and be installed in accordance with the design.

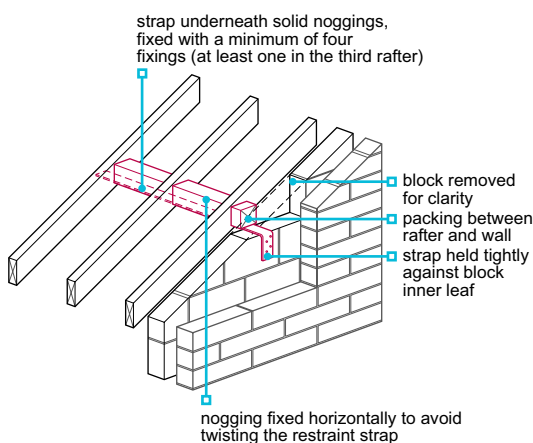
Lateral restraint straps should be located:

- for homes up to and including three storeys (two storeys in Scotland), at a maximum spacing of 2m
- for homes four storeys or over, fixed at a maximum spacing of 1.25m.

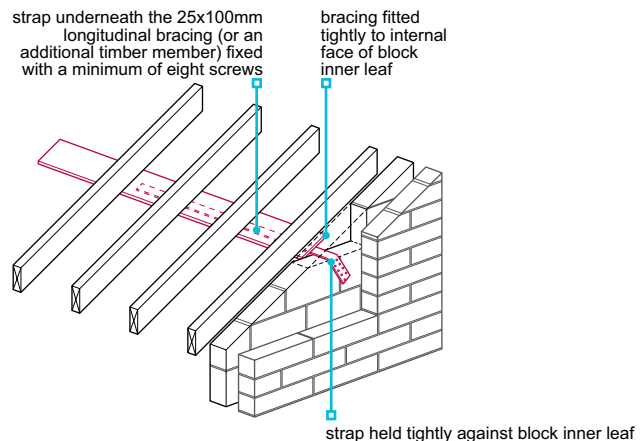
Lateral restraint straps should be fixed to the roof structure by either:

- fixing to solid noggings using four 50mm minimum x 4mm steel screws or four 75mm x 4mm (8SWG) round nails, with one fixing in the third rafter (Figure 1), or
- fixing to longitudinal bracing members using eight 25mm x 4mm steel screws evenly distributed along the length of the strap (Figure 2). Additionally, 100mm x 25mm timber members, fixed over four trusses and nailed in accordance with clause 7.2.9 can be used where the position of the strap does not coincide with a longitudinal binder.

**Figure 1**



**Figure 2**



Lateral restraint straps should be:

- ordered and supplied according to the design, i.e. the correct length and number of bends and twists
- provided at rafter level on gable walls, where the home is of masonry construction (larger or separating walls may require restraint at ceiling level)
- protected against corrosion in accordance with BS EN 845 - Tables A.1 and A.2 (sherardised straps or fixings are not acceptable in Northern Ireland and the Isle of Man)
- of sufficient length to be fixed to a minimum of three trusses
- a minimum size of 30mm x 5mm and have a minimum anchorage downturn to 100mm or proprietary straps in accordance with Technical Requirement R3 and installed in accordance with the manufacturer's recommendations
- fixed with the downturn on a substantial piece of blockwork, preferably fitted over the centre of an uncut block
- in accordance with BS EN 1995-1-1, where the home is of timber frame construction.

In framed roofs, as an alternative, purlins and pole plates can be used to provide restraint where the timber abuts a gable construction. Where purlins are used to provide restraint, the maximum permissible spacing is 2m unless the design shows otherwise.

Gable ladders can be used to provide restraint to the external wall where:

- there is blocking between the last trussed rafter and the inner leaf (maximum 2m spacing)
- the soffit board is cut carefully and then fixed securely to restrain the outer leaf.

### Bracing for trussed rafter roofs <sup>7.2.9</sup>

Also see: *ITPA Technical Handbook BS 5268-3 (AMD.5931) Appendix A*

**Trussed rafters shall be suitably braced to support applied loads and self-weight without undue movement.**

For the purposes of this chapter, the guidance and use of standard trussed rafter bracing does not apply to homes on or near exposed sites, e.g. flat coastal fringes, fens, airfields and moorland. In such cases, bracing should be designed by an engineer in accordance with Technical Requirement R5.

Standard trussed rafter bracing, in accordance with Table 4, is generally acceptable, where the home:

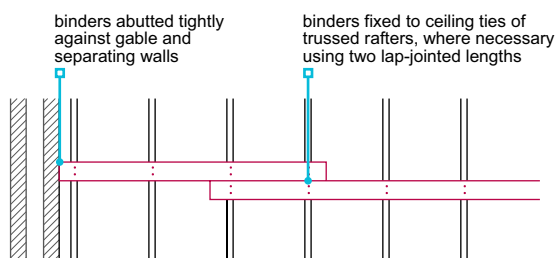
- has a rectangular roof (including hip ends) and is either a duo-pitched or a mono-pitch structure
- is not taller than 8.4m (to the underside of the ceiling tie)
- is braced in accordance with this chapter
- is braced according to the conditions of the site and in accordance with the design
- does not have trusses which span more than 12m
- has trusses which are only supported at each end
- does not have unsupported masonry spanning more than 9m (between buttressing walls, piers or chimneys)
- has a ceiling of plasterboard directly under each truss (where there is no plasterboard, i.e. garages, additional diagonal ceiling bracing and longitudinal binder bracing at each ceiling node point is required).

**Table 4:** Location, height and span for standard bracing conditions

	Type	Duo-pitch						Mono-pitch														
		Maximum pitch						35°			30°			35°			30°			25°		
		Storeys						1	2	3	1	2	3	1	2	3	1	2	3	1	2	3
Maximum span (m)	England and Wales	10.6	9.1	8.5	12	11.5	10.2	5.6	4.5	4.3	6.6	5.8	5.1	8.1	7.2	6.4						
	Scotland	9.8	7.7	7.2	11.6	10.0	8.8	4.9	4.2	3.6	5.8	5.0	4.4	7.3	6.4	5.6						
	Areas north or west of Ullapool	8.6	7.2	6.0	10.6	8.7	7.5	4.3	3.6	3.0	5.1	4.4	3.7	6.5	5.6	4.5						
	Northern Ireland and the Isle of Man	9.8	7.7	7.2	11.6	10.0	8.8	4.9	4.2	3.6	5.8	5.0	4.4	7.3	6.4	5.6						
	Areas north-east of Londonderry	8.6	7.2	6.0	10.6	8.7	7.5	4.3	3.6	3.0	5.1	4.4	3.7	6.5	5.6	4.5						

Roof bracing should be:

- in accordance with this chapter or PD6693-1
- in accordance with the design and not altered without prior approval from the designer
- appropriate for the site (where the site is in an exposed location, the design should be checked for additional requirements, and the bracing completed as specified suitably fixed to the wall plate)
- completed before the roof covering is laid
- provided using a minimum timber size of 100mm x 25mm (3mm tolerance)
- nailed twice to each rafter it crosses; fixings should be 3.35mm x 65mm (10 gauge) galvanized round wire nails
- where braces and binders are not continuous, they should be lap jointed and nailed to a minimum of two trusses.



When bracing pitched roofs:

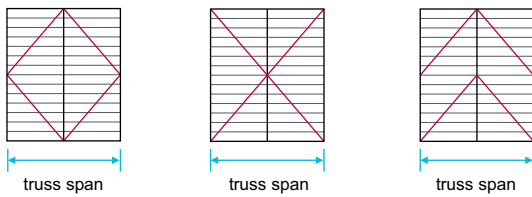
- diagonal and longitudinal bracing should be provided at rafter level (this may be omitted where rigid sarking boards are used, e.g. chipboard, plywood or OSB, which are fixed to each trussed rafter with 3mm x 50mm galvanised round wire nails at 200mm spacing)
- diagonal and chevron bracing should pass across each rafter in the roof, however, small gaps, such as two trussed rafters between sets of bracing, or one trussed rafter adjacent to gable or separating walls, is permitted in the middle of an otherwise fully braced roof
- longitudinal bracing members should extend the full length of the roof, tightly abut gable and party walls and permit diagonal bracing to pass (they may be lap-jointed providing the overlap is nailed to a minimum of two trussed rafters)
- there should be a minimum of four diagonal rafter braces in each roof; in narrow fronted roofs and mono-pitched roofs, where the braces cross, the intersection detail (below) should be used.

#### Diagonal rafter bracing

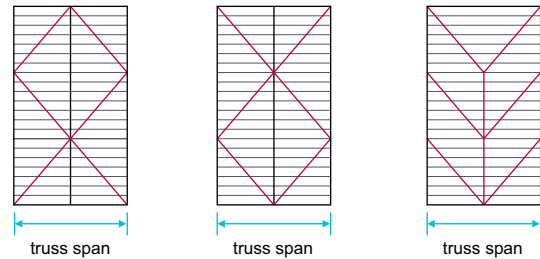
Applicable to all trussed rafter roofs unless rigid sarking, such as timber boarding or plywood, is used.

Diagonal rafter bracing should be approximately 45° to the rafters on plan.

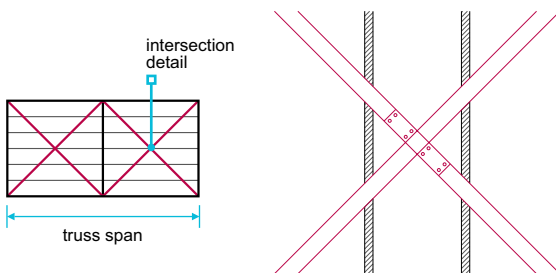
**Bracing for roofs that are approximately square**



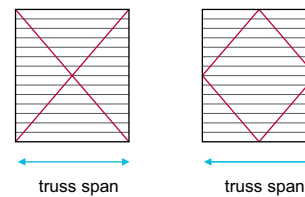
**Bracing for larger roofs**



**Bracing for roofs less than 6.6m wide on detached or staggered/stepped buildings**



**Bracing for mono-pitch trusses**



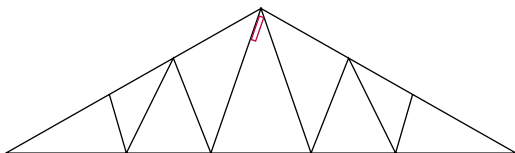
Intersection details should be formed by:

- 22mm x 97mm x 600mm timber splice plate

- nailing, using a minimum of four 35mm x 65mm galvanised round wire nails to each side of the intersection, with nails driven through bracing and clenched over.

**Longitudinal bracing member at ridge node point**

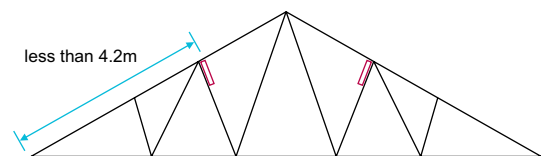
Applicable to all trussed rafter roofs. Not necessary where rigid sarking, such as OSB, timber boarding or plywood sheeting, is used.



**Longitudinal bracing member at rafter node point**

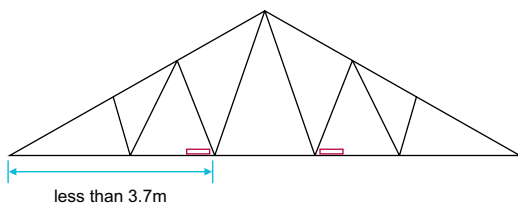
Applicable to all rafter node points. Not necessary where:

- spacing between braced nodes is less than 4.2m, or
- rigid sarking, such as OSB, timber boarding or plywood sheeting, is used.



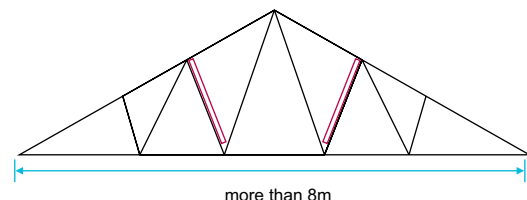
**Longitudinal binders at ceiling node points**

Applicable to all ceiling node points. Not necessary where the spacing between braced nodes is less than 3.7m.



**Chevron bracing between webs**

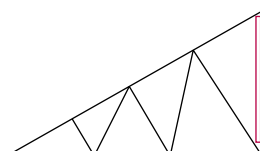
Where the span exceeds 8m. For mono-pitch roofs of any span and duo-pitch roofs over 11m span, bracing should be designed by an engineer in accordance with Technical Requirement R5. It should be approximately 45° to the web members.



**Diagonal bracing to end vertical of mono-pitch trusses**

Applicable where the truss is not restrained by:

- a masonry wall, or
- cladding, i.e. plywood.



### Strutting for attic trusses and cut roofs that form a floor <sup>7.2.10</sup>

**Strutting to attic trusses shall be provided to support the applied loads and self-weight without undue movement or distortion.**

Strutting should be provided:

- in accordance with the design
- where the span between the node points which form the width of the floor of the attic truss exceeds 2.5m
- where the span between the supports to a floor within a cut roof exceeds 2.5m
- using herringbone (38mm x 38mm timber) or solid strutting (a minimum of 0.75x the depth of the floor and a minimum of 38mm thick).

**Table 5:** Provision of strutting

Span of floor	Rows of strutting
Under 2.5m	None required
2.5m-4.5m	One (at centre of span)
Over 4.5m	Two (at equal spacing)

### Support for equipment <sup>7.2.11</sup>

**Permanent equipment in roof voids shall be adequately supported.**

Where equipment (e.g. water tanks and MVHR fan units) is located in the roof void, the structure should be designed in accordance with PD 6693-1 and the truss manufacturer's recommendations, to support the additional load.

### Access <sup>7.2.12</sup>

*Also see: Clause 7.2.15*

**Roof voids shall be provided with suitable access.**

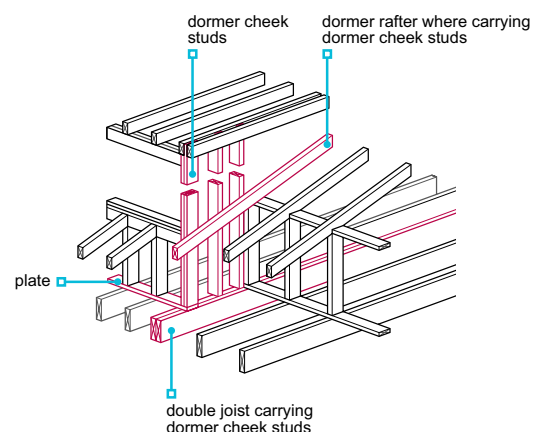
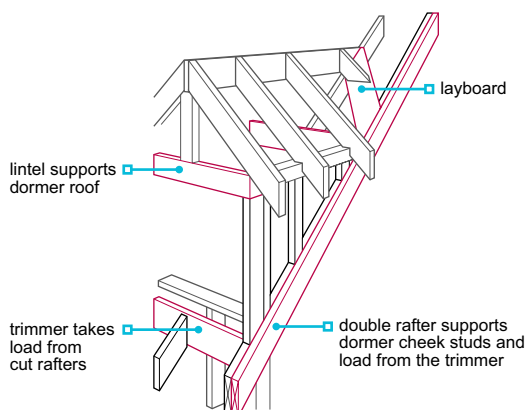
Access should:

- be provided to the main roof space and voids which contain cisterns and tanks etc. though it is not required to roof spaces which contain only water pipes
- permit the removal of permanent equipment (e.g. heating and ventilation plant) located in the roof space
- have a minimum opening width of 520mm in each direction
- not be located directly over stairs or in other hazardous locations
- include securely fixed boarded walkways between the opening and the cistern or other permanent equipment; boarding should be securely fixed without compressing the insulation; at each piece of permanent equipment or cistern, a minimum 1m<sup>2</sup> platform should be provided to facilitate maintenance.

Access hatches should be in accordance with Clause 7.2.15. Where an access hatch is required to provide fire resistance, the fire-resistance period should be supported by test evidence.

### Dormer construction <sup>7.2.13</sup>

**Dormer constructions shall be of adequate structural stability.**



For dormer roofs:

- construction should be in accordance with the design
- cheek studs should be supported by either a double rafter or a double floor joist
- where cheek frames do not extend to floor level, two fixed rafters should be used to provide the necessary support
- trimming members should be large enough to support additional loads from the main roof members, dormer framing and cladding
- a suitable lintel should be provided over the opening
- lintels should be structurally independent from the window frame.

### Underlay and sarking <sup>7.2.14</sup>

**Underlay and sarking shall be provided to resist the passage of moisture and condensation.**

Underlay and sarking should:

- be in accordance with the manufacturer's recommendations
- take account of the type and fixing of the roof covering
- be used in accordance with relevant assessments.

In areas of severe exposure, a rigid sarking with underlay is recommended.

**Table 6:** Acceptable materials for use as underlay and sarking

Material	Standard
Tongued and grooved or square-edged boarding	BS 1297
Bitumen impregnated insulating board	BS 1142-3 (sarking and sheathing grade)
Exterior grade plywood	BS EN 636 service class 3
Chipboard (type P5)	BS EN 312
OSB (type OSB3)	BS EN 300
Felt	BS EN 13707
Proprietary products	Technical Requirement R3

Underlay should:

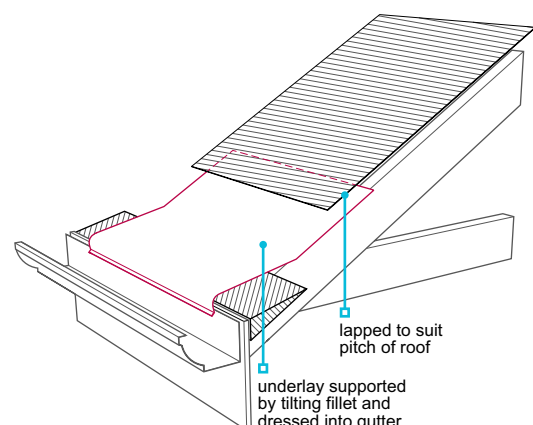
- be provided to all tiled roofs
- where it is above rigid sarking (fully supported), be of low vapour resistance, i.e. less than 0.25MNs/g (where the underlay is highly vapour-resistant, increased ventilation to the roof space or between the underlay and sarking should be provided as necessary)
- where exposed at eaves level, be UV resistant or of type 5U felt or a proprietary eaves guard used (type 1F may be used for the remainder of the roof)
- be supported by a continuous fillet or proprietary eaves support tray to prevent sagging (which can form a water trap)
- be securely fixed
- at vertical laps, be fixed only over rafters, and at horizontal laps, be held in place by battens (spaced at regular intervals)
- be cut neatly, fit tightly and not be torn, i.e. where pipes project through the underlay
- be dressed into the gutter and cut neatly to fit tightly around service penetrations
- where traditional mortar pointing is used to bed ridge tiles, extend over the ridge
- continue over hips to form a 150mm minimum lap parallel with the hip rafter
- at abutments, be supported and turned up by a minimum of 100mm
- be draped to allow water to drain behind the tiling battens.

**Table 7:** Horizontal laps for unsupported underlay

Pitch	Minimum horizontal laps
Less than 15°	225mm
15-34°	150mm
35° and above	100mm

At valleys:

- the main roof underlay should be cut to the valley batten line
- a strip of underlay should be laid under the main roof underlay and held down by the valley battens (where used).



### Ventilation, vapour control and insulation <sup>7.2.15</sup>

Roofs shall have adequate precautions against condensation and cold. Issues to be taken into account include:

- a) ventilation, vapour control and insulation
- b) dormer construction
- c) pipework.

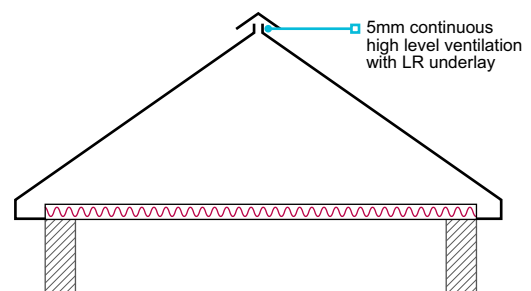
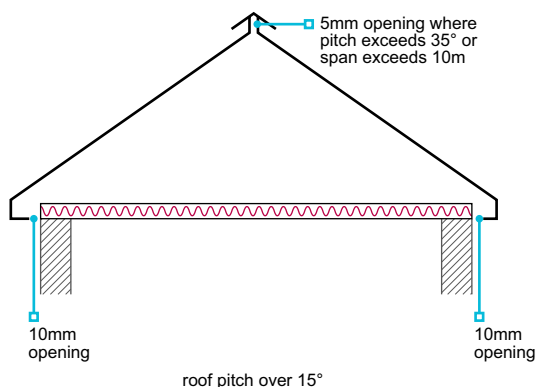
#### Ventilation, vapour control and insulation

To provide adequate ventilation and to avoid condensation in roof voids, pitched roofs that have insulation at ceiling level should be ventilated to the outside air:

- Ventilation openings should prevent the entry of birds, etc. (fabrications with 3mm-10mm openings are acceptable)
- Ventilation paths should remain clear, i.e. not blocked by insulation or the structure
- A spacer in the eaves should be used to allow insulation to be installed over and beyond the wall plate to minimise the cold bridge without blocking the ventilation path (the spacer should be of sufficient length to maintain ventilation above the insulation)
- Where proprietary eaves ventilators are used, they should be fixed in accordance with the manufacturer's instructions.

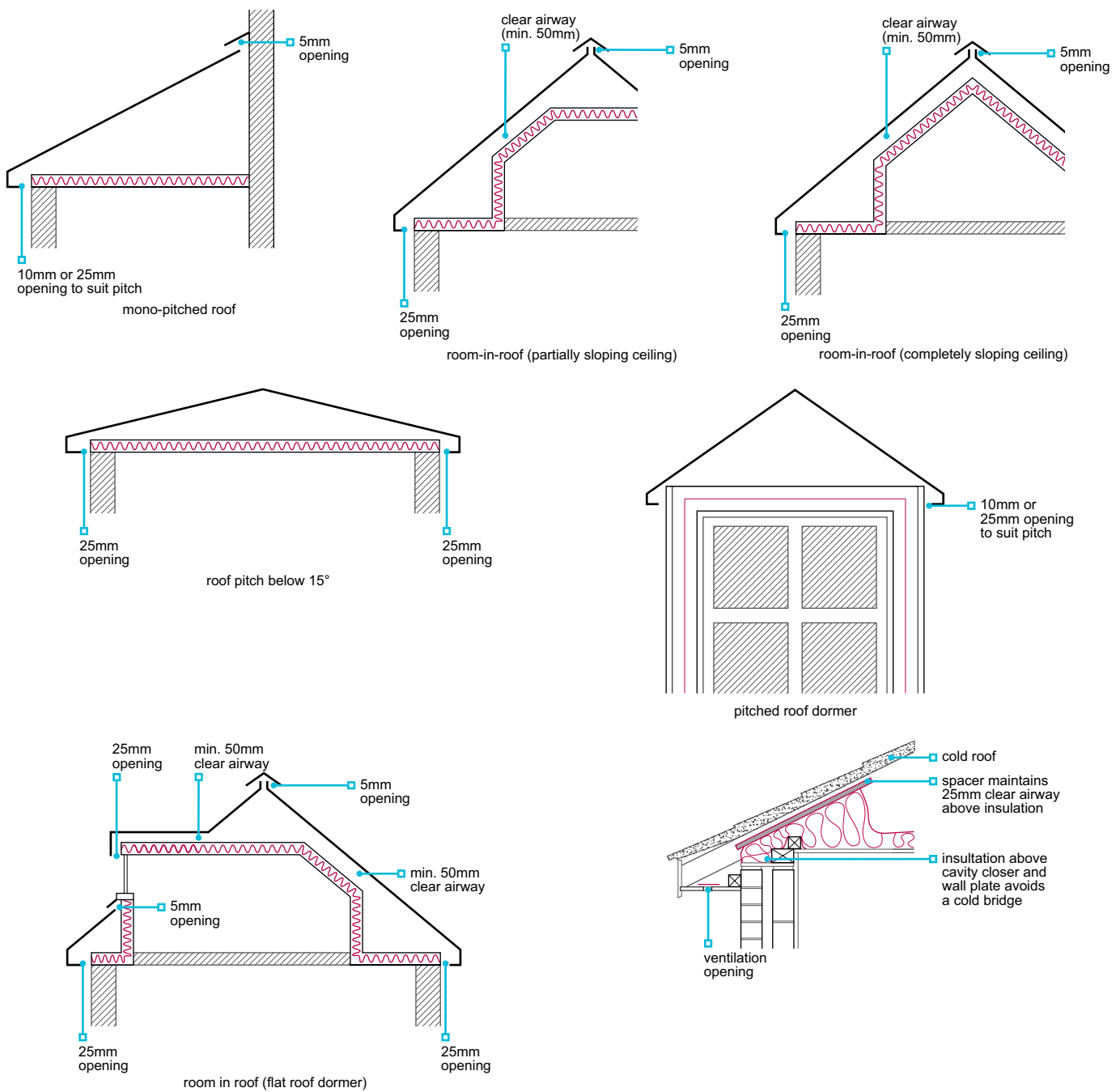
Ridge or high-level ventilation equivalent to a continuous opening of 5mm should be provided at the highest point of each roof slope in accordance with BS 5250 in the following situations:

- Unventilated cold roofs have insulation placed over a horizontal ceiling and a vapour-permeable underlay (type LR) is used.
- Vapour permeable underlays are used on sloping roofs with areas covered by non-permeable materials (e.g. flat roofed areas of mansard roofs).
- The roof is covered with high water vapour resistant (type HR) underlay and the pitch exceeds 35° or the span exceeds 10m (this is in addition to eaves ventilation).



Where high water vapour-resistant (type HR) underlay (e.g. types 1F/5U felts) is used, eaves ventilation should be provided on opposite sides of the roof to permit cross ventilation, and:

- where the roof pitch is 15° or more, ventilation equivalent to a 10mm slot running the full length of the eaves should be provided
- where the ceiling follows the slope of a roof, regardless of pitch, or where a cold roof has a pitch less than 15°, ventilation equivalent to a 25mm slot running the full length of the eaves should be provided (a nominal clearance of 50mm should be maintained between the insulation and the roof underlay)
- for mono-pitched roofs, cross ventilation should be in accordance with BS 5250 and have ventilation equivalent of a continuous high-level 5mm slot, in addition to eaves ventilation.



To reduce moist air entering the roof space:

- gaps should be sealed where services pass through the ceiling

- where used, downlighters should be specified and sealed to limit air leakage.

Vapour control layers should be provided in accordance with the design, and where required should be:

- placed on the warm side of insulation

- used in roof constructions where the ceiling board is fixed to the rafters.

Where the ceiling below a cold pitched roof includes a vapour control layer, the design should ensure adequate ventilation is provided to prevent condensation problems in the home.

Access hatches to cold roof voids should have:

- an air leakage rate not more than 1 M<sup>3</sup>/h at a pressure of 2 Pa when tested to BS EN 13141-1, or

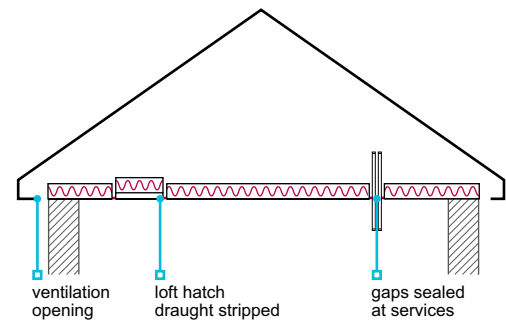
- a push-up cover with a minimum weight of 5.5 kg and compress a closed cell seal or 'o-ring' between the cover and frame (clamps may also be required to ensure that the cover compresses the seal).



The thermal performance of the access hatch should contribute to the overall thermal performance of the ceiling or wall in which the hatch is located, and avoid cold bridging.

Proprietary hatches should be fitted and sealed to the surrounding construction in accordance with the manufacturer's instructions.

Insulation should be of sufficient thickness to meet the requirements of Building Regulations, and laid over the whole loft and wall plate.



**Table 8:** Suitable materials for roof insulation

Material	Standard
Mineral fibre mats	BS EN 13162
Blown mineral fibre	BS 5803-2
Blown cellulose fibre	BS 5803-3
Proprietary products	Technical Requirement R3

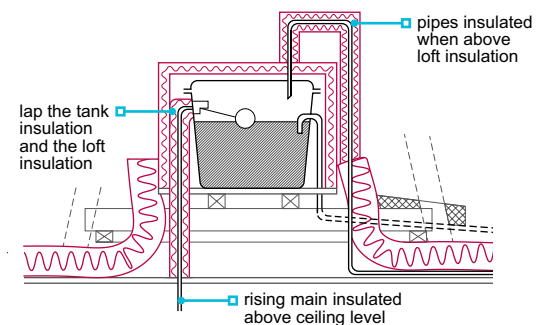
### Dormer construction

Ventilation to dormers should be provided from eaves to eaves or from eaves to ridge.

### Pipework

To reduce the risk of freezing or condensation forming on pipework, the following precautions should be taken:

- Where possible, water pipes should be below the main roof insulation.
- Water pipes should be insulated in accordance with Chapter 8.1 'Internal services'.
- Roof insulation should be placed above and around water tanks, but not below them.
- 'Cold rising' pipework above ceiling level should be insulated, even where it is below the main roof insulation.



In England and Wales, account should be taken of Accredited Construction Details.

### Firestopping and cavity barriers <sup>7.2.16</sup>

Also see: Chapter 6.8

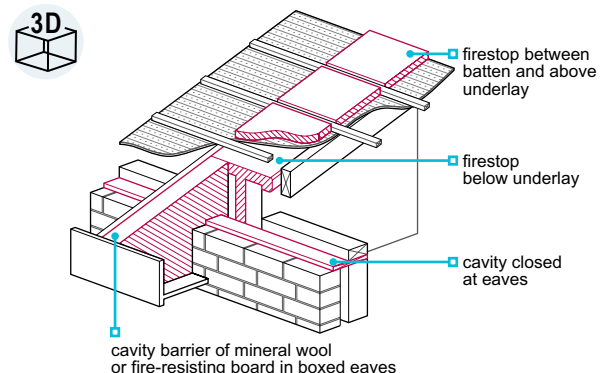
**Pitched roofs shall be constructed to provide adequate fire resistance and separation.**

Firestopping should be provided in accordance with building regulations, including:

- at the junctions between a separating or compartment wall and a roof
- at the junctions between cavities
- above separating walls
- within the boxed eaves at separating walls.

When providing firestopping:

- gaps between compartments should be sealed
- separating walls should stop approximately 25mm below the top of adjacent roof trusses, and a soft fire-resistant packing, such as mineral wool, should be used to allow for movement in roof timbers and prevent 'hogging' of the tiles
- a cavity barrier of fire-resisting board or a wire reinforced mineral wool blanket (50mm minimum) nailed to the rafter and carefully cut to fully seal the boxed eaves should be installed (ordinary mineral wool quilt is acceptable as firestopping above separating walls)
- a minimum 30min fire separation should be provided between the home and an integral garage.



Combustible material, such as roof timbers and sarking felt, should be kept away from heat sources.

**Battens** <sup>7.2.17</sup>

**Battens and counter battens shall be adequately sized and spaced to support the roof covering.**

Battens and counter battens should be:

- in accordance with BS 5534, accompanied by a delivery note and marked with the supplier, origin, grade and size
- preservative treated
- where cut ends are in contact with mortar, treated with preservative
- cut square, butt jointed over rafters and nailed to each rafter they span
- fixed by skew driven nails on each side of the joint.

Counter battens should be fixed to the rafters and not only to sarking boards.

Battens should be:

- a minimum of 1.2m long and span a minimum of three rafters
- set out in straight lines parallel to the ridge and to the gauge required for the tile or slate (the lap should not be decreased as this would reduce weathertightness)
- set out so that the tiles project a minimum of 50mm over the gutter
- fixed through counter battens to rafters
- where on rigid sarking boards, supported on counter battens
- at verges, tile battens should finish 25mm-50mm from the face of the protecting undercloak
- sized in accordance with the roof covering manufacturer's recommendations, but not less than shown in Table 9.

**Table 9:** Suitable batten sizes

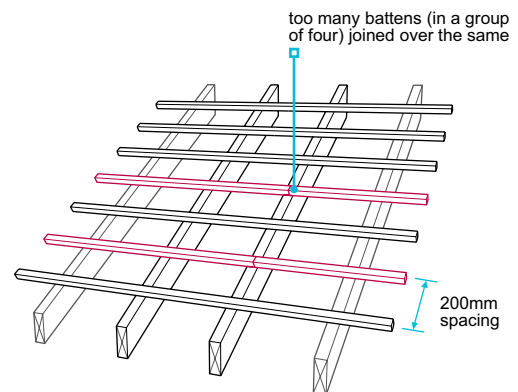
		450mm span	600mm span
Double lap slates	Natural: sized or random	25mm x 50mm	25mm x 50mm
	Fibre cement or concrete	25mm x 38mm	25mm x 50mm
Clay/concrete tiles	Double lap	25mm x 38mm	25mm x 38mm
	Single lap	25mm x 38mm	25mm x 50mm

Notes

- 1 Actual size should be within +/-3mm of the nominal size).

Battens should be set out to avoid joints occurring over the same rafter. Where batten spacing is:

- more than 200mm, no more than one batten in any group of four should be joined over any one truss or rafter
- 200mm or less, no more than three joints should be made over any 12 consecutive battens.



Batten fixings should be:

- cut or wire nails in accordance with BS 5534
- a minimum of 3.35mm x 65mm long (10 gauge) and a minimum of 30mm longer than the batten thickness
- ring shank nails where specified (where the maximum basic wind speed is over 26m/s (National Annex Figure NA.1 of BS EN 1991-1-4), galvanized smooth round nails are not acceptable and ring shank nails should be used)
- hot dip galvanised steel or aluminium, when used in coastal areas
- in accordance with manufacturer's guidance where mechanical nail guns are used.

**Roof coverings** <sup>7.2.18</sup>

**Roof coverings shall be of a suitable quality and durability to protect the building from weather.**

When covering a pitched roof:

- coverings should be in accordance with the design and established building practices
- recovered materials may be used where prior approval by NHBC has been granted (independent certification of suitability may be required).

**Table 10:** Standards relevant to roof coverings

Material	Standard
Clay tiles and fittings	BS EN 1304
Concrete tiles and fittings	BS EN 490 and BS EN 491
Natural slates	BS EN 12326
Fibre cement slates and fittings	BS EN 492
Natural stone	Established practices
Lead sheet roofing	BS 6915
Rolled lead sheet	BS EN 12588
Thatch	Standards set by the Thatching Advisory Services or other appropriate authority, in accordance with Technical Requirement R3
Shingles should be of western red cedar	Grade 1 to the Canadian Standards Association
Sheet metal roofing, including lead, copper and zinc	Technical Requirement R3
Proprietary roofs, roof lights, dry fixed systems and coverings	Technical Requirement R3
Other roof coverings	CP 143

Where slates and concrete or clay tiles are designated AA to BS 476-3, they can be used without limitation on pitched roofs.

**Table 11:** Acceptable characteristics for natural slates

Characteristics	Grade (to BS EN 12326)
Water absorption less than 0.6%	A1
Thermal cycle	T1
Carbonate content less than 20%	S1

### Fixing tiles and slates <sup>7.2.19</sup>

Also see: BS 5534

**Coverings shall be suitably fixed to protect the building from weather. Issues to be taken into account include:**

- |                               |                                 |
|-------------------------------|---------------------------------|
| a) eaves, ridge and hip tiles | c) mortar                       |
| b) verges                     | d) vertical tiling and slating. |

Careful setting out will improve the finished appearance of the roof, help avoid problems such as unequal overhangs, and reduce excessive tile cutting at abutments, chimneys and similar obstructions.

When installing coverings:

- clay tiles that do not meet the dimensional and geometric requirements given in BS EN 1304 should not be laid at pitches less than 40°
- joints between tiles and slates should be slightly open, which provides some flexibility in setting out and should help to avoid tile cutting (single lap interlocking tiles have a tolerance of approximately 3mm at the joint)
- double tiles, tile-and-a-half or half tiles can be used when available from the manufacturer (to avoid the use of small sections of cut tiles). Alternatively, where the tile manufacturer provides guidance, small sections of single lap tile can be bonded to full tiles
- the bottom edges of double-lapped slate and plain tile roofs should be finished with an under-eaves course.

**Table 12:** Pitch, gauge and lap

Type or tile	Gauge	Minimum headlap	Minimum permissible pitch (°)
Plain (double lap)	Maximum 1/3 length lap	65mm generally for clay tiles 75mm in severe exposure conditions	35 (clay) 35 (plain concrete)
Concrete (single lap interlocking)	Comply with the manufacturer's recommendations	75mm or to the manufacturer's recommendations	30 <sup>(2)</sup>
Slates (double lap)	Maximum 1/3 length lap	54mm <sup>(1)</sup> minimum, increased with lower pitch and severe exposure conditions	20 subject to headlap

Notes

- 1 For pitches greater than 45° in sheltered and moderate exposure zones only.
- 2 For pitches below 30°, evidence shall be provided as to suitable performance.

When fixing coverings to a pitched roof:

- the fixing schedule should be produced by the tile manufacturer; fixings for single and double lap tiles should be in accordance with BS 5534 and BS EN 1994-1-4 (evidence of calculations in compliance with Technical Requirements R3 and R5 may be required)
- coverings should be fixed in accordance with the design and the manufacturer's recommendations
- slates and tiles should be fixed using clout or slate nails (these should be either silicon bronze, aluminium to BS 1202-3 or copper to BS 1202-2).
- galvanized steel nails should not be used for slates and tiles (but are acceptable for fixing battens or underlay)
- fixings should be a minimum of 38mm long, and penetrate a minimum of 15mm into battens
- tile clips should be of aluminium or stainless steel
- slates should be fully nailed over the whole roof, and nailed twice where centre nailed.

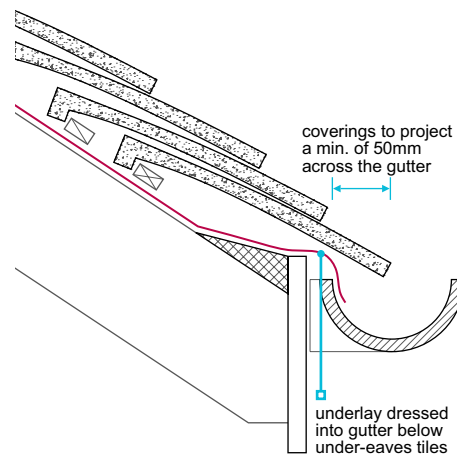
### Eaves, ridge and hip tiles

At eaves:

- tiles should project a minimum of 50mm across the gutter
- when using slates or plain tiles, an under-eaves course should be used
- the height of the fascia should maintain the tile pitch, in accordance with the tile manufacturer's recommendations.

Where ridge tiles are mortar bedded:

- the underlay should extend over the ridge.

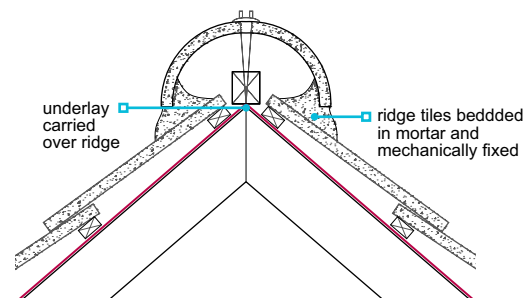
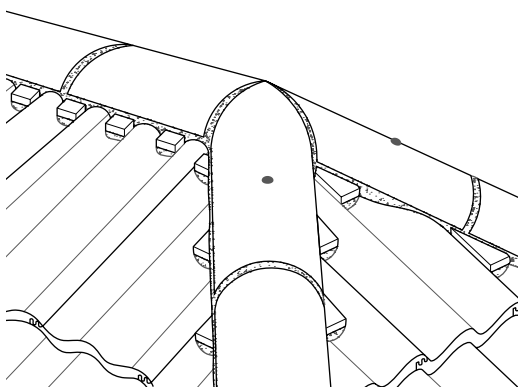


At hips:

- underlay should continue to form a 150mm minimum lap parallel with the hip rafter
- where wet bedded tiles are used, they should be supported at the base by a galvanized hip iron and project to the centre line of the gutter.

All ridge and hip tiles should be mechanically fixed with self-sealing non-ferrous fixings into timber battens, and have a nominal joint thickness of 10mm where wet bedded.

Proprietary dry fixed systems should be assessed in accordance with Technical Requirement R3.

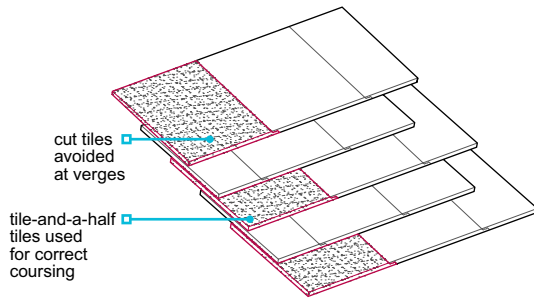


### Verges

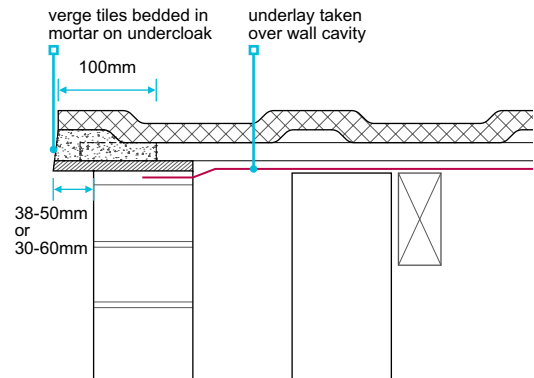
Unless a proprietary dry verge system or cloaked verge is used, tiles should be bedded into a 100mm wide bed of mortar on an undercloak of cement-based board, plain tile or slate. Plain tiles should not be used as an undercloak below 30° pitch or on a bargeboard.

Undercloak should be:

- fixed in accordance with manufacturer's recommendations
- installed to a true line
- installed at the correct level to ensure that the line of the tiling is maintained where it passes over the wall, and not tilt inwards



- bedded on roofing mortar and struck off flush with the external surface of the wall (alternatively, a suitable exterior grade bedding sealant should be used in accordance with the manufacturer's recommendations)
- securely nailed to a true line where a bargeboard is used.



Where verge tiles and slates are wet bedded, pointing should be completed as soon as possible using the same mix.

Verge clips should be in full contact with the tile to resist uplift, nailed twice to battens and sized to ensure that they are in direct contact with the top surface of the verge tile.

Where plain tiles and slates are used at the verge:

- they should project 38-50mm beyond the gable wall or bargeboard
- cut plain tiles are not acceptable, and purpose-made plain tile-and-a-half tiles should be used

- natural slate verges should be formed with full slates and either slate-and-a-half or half slates that are a minimum of 150mm wide.

Where interlocking tiles are used at the verge:

- they should project 30-60mm beyond the gable wall or bargeboard

- small sections (less than a half tile width) of cut interlocking tiles should not be used.

### Mortar

When bedding tiles or slates in mortar:

- the mortar should be 1:3 cement:sand with plasticiser
- the mortar should be a mix based on sharp sand with soft sand added to achieve workability; the proportion of sharp sand should not be less than one third of the total sand content (proprietary mixes may be accepted by NHBC where they are shown to have similar strength, durability and workability)

- pointing should be completed as soon as possible using the same mix.
- tiles should be wetted on their contact surface, and surface water allowed to drain away before fixing
- concealed or decorative dentil tiles should be fully bedded into joints in excess of 25mm thick.

### Vertical tiling and slating

When fixing vertical tiling and slating:

- a suitable moisture barrier should be used
- where the wall structure is solid brickwork or blockwork, the moisture barrier should be underfelt or equivalent
- where the supporting structure is of timber construction, the moisture barrier should be used with a breather membrane
- batten sizes should be in accordance with this chapter
- every tile or slate should be nailed twice and the bottom edges should be finished with an under-course tile

- at internal or external angles, purpose-made corner tiles or soakers should be used to form a weathertight joint
- where pitched roofs abut tiled walls, a stepped flashing should be specified and turned in behind the tiles
- at dormer cheeks, the tiles or slates should be specified to be cut close to the slope of the roof and over a flashing fixed to the side of the dormer.

**Weathering details** 7.2.20

Also see: Chapter 6.8

**Weatherproofing shall be provided at abutments, flat roof intersections, changes in slopes and projections to resist the passage of moisture to the inside of the building. Issues to be taken into account include:**

- a) abutments
- b) flat roof intersection or changes in slope
- c) projections through the roof
- d) copings.

Flashing details should be appropriate for the roof and the type of roof covering used, in accordance with BS 5534. Where flashings come into contact with metal, they should be formed using non-ferrous material.

**Table 13:** Suitable materials for flashings

Material	Standard	Additional information
Aluminium and alloys	BS EN 515	0.6-0.9mm thick, and protected from contact with mortar by a coating of bituminous paint
Copper	BS EN 1172	Flashings, soakers and saddles should be: <ul style="list-style-type: none"> <li>■ fully annealed</li> <li>■ 0.55mm thick (0.7mm thick is suitable for gutters)</li> </ul>
Rolled lead sheet	BS EN 12588	Flashings, gutter linings etc. should: <ul style="list-style-type: none"> <li>■ be a minimum of code 4, and soakers a minimum of code 3</li> <li>■ sections should not exceed 1.5m in length</li> </ul>
Zinc alloy	BS EN 988	Should be a minimum of 0.6mm thick
Proprietary products	Technical Requirement R3	Should be securely fixed in accordance with the manufacturer's recommendations

**Abutments**

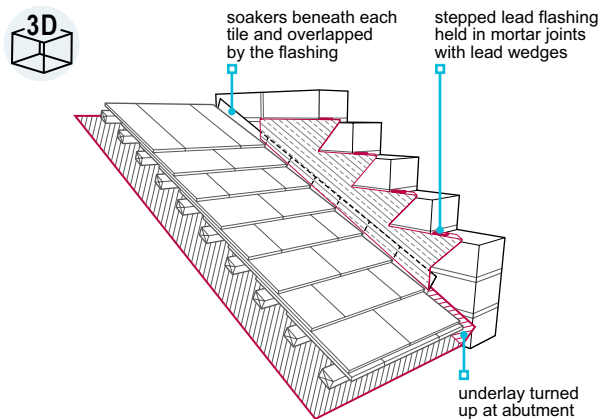
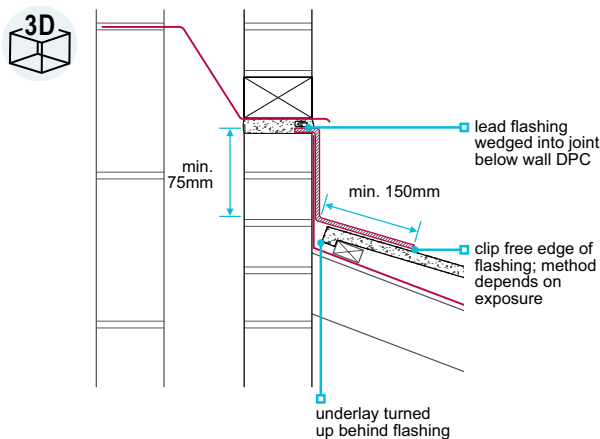
At abutments:

- flashings, soakers and gutters should be provided as necessary
- lead flashings should have a minimum lap of 100mm
- flashings should be tucked 25mm into a brick joint and wedged in place at not more than 450mm centres, or a minimum of one per step for stepped flashings
- joints between the masonry and flashing should be pointed with cement mortar or suitable exterior grade sealant in accordance with the manufacturer's recommendations.

Where a flat or pitched roof over an enclosed area abuts a wall, or a balcony abuts a wall, cavity trays should be linked to the flashing to prevent water penetrating into an enclosed area. Horizontal flashings should provide weathering to a minimum of 75mm above the intersection with the roof.

Where a pitched roof abuts the wall at an angle:

- a stepped cavity tray linked to a stepped flashing should be used
- stepped flashings should be cut from a strip a minimum of 150mm wide
- stepped flashings should be a minimum of 65mm wide
- where slates, flat interlocking tiles or plain tiles are used, soakers (or a secret gutter) should be installed.



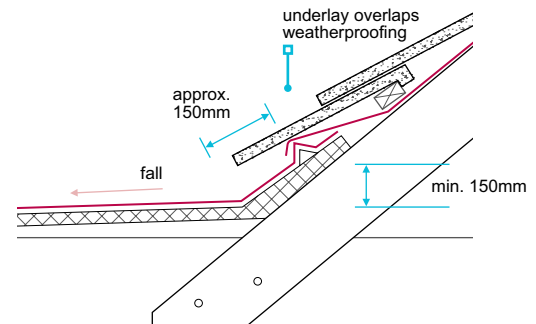
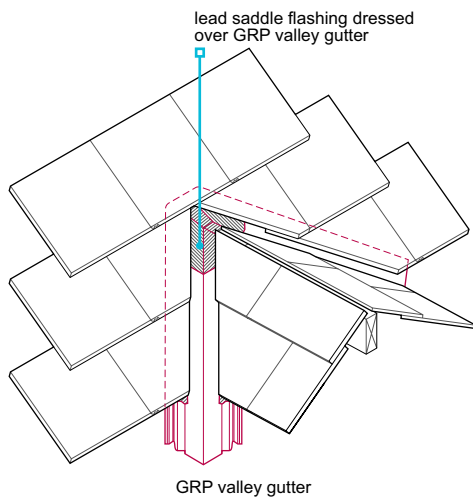
### Flat roof intersection or changes in slope

Where there is a change in the slope, or an intersection with a flat roof and:

- the change is 5° or more (e.g. at mansards and sprockets), flashings or soakers should be used
- a ridge meets the main roof, a saddle flashing should be used where a ridge meets the main roof.

Where a flat roof adjoins a pitched roof:

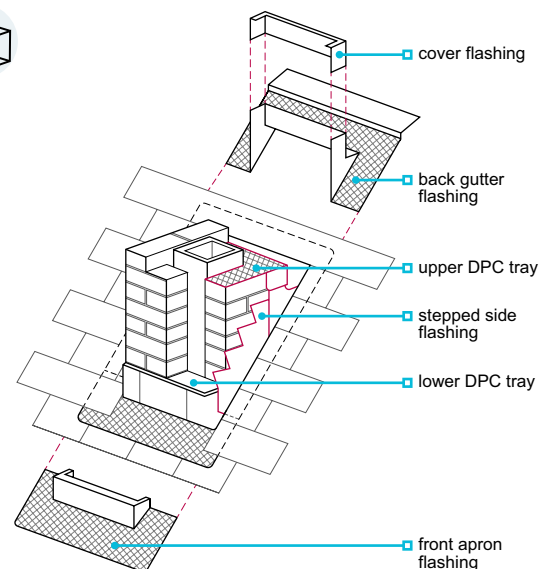
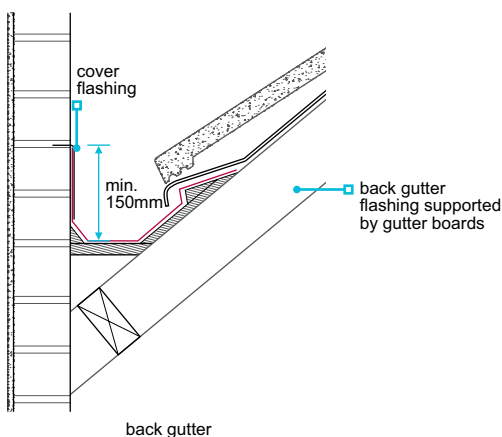
- the waterproof membrane should be carried up under the tiling to a height of 150mm above the flat roof, and lapped by the roofing underlay
- the lowest course of tiles or slates should not touch the roof membrane
- where the flat roof is over a dormer, the flat roof should have a fall to the front or sides.



### Projections through the roof

Where there is a projection through the roof:

- components should be installed according to the manufacturer's recommendations
- flashings should be provided (e.g. at chimneys)
- where pipes penetrate tiling, a weathertight joint should be formed using a lead slate flashing and upstand or a purpose-made one-piece accessory (supplied by the roof covering manufacturer); where lead slates are used they should be supported (e.g. using exterior grade plywood) to prevent sagging.



## Copings

Copings, including those manufactured from natural stone reconstituted stone, and GRP, should be securely fixed to gable walls using suitably durable fixings, and be weathertight.

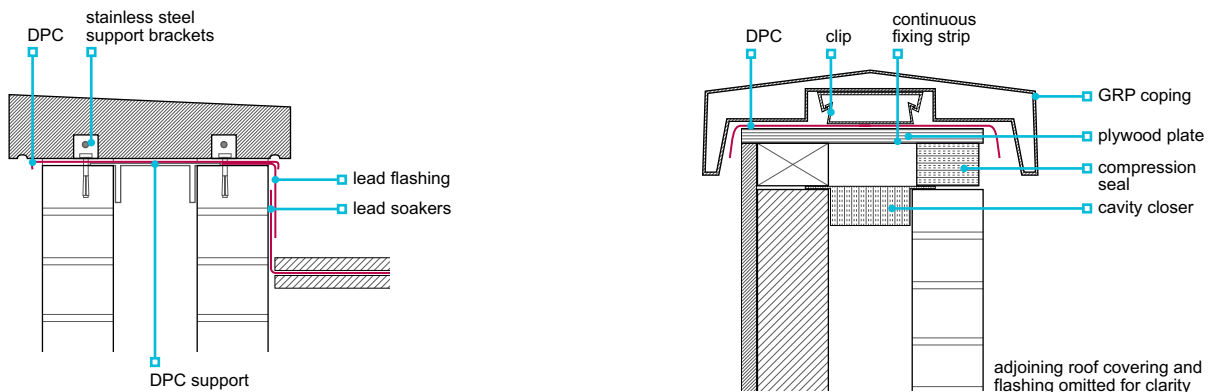
To resist wind uplift and gravitational forces, L-shaped brackets should be used to secure stone copings to masonry walls. The brackets should:

- have dowel bars that fit into restraint holes in the copings
- be manufactured from stainless steel (such as type 304 to BS EN 10088-2)
- be fixed to a solid piece of masonry, with fixings of a suitable length, gauge and durability.

DPCs should be installed under the coping to ensure that the wall is weathertight. The DPC should:

- be bitumen-based material to BS 6398, or other material assessed in accordance with Technical Requirement R3
- extend the full width of the wall
- be fully bedded in mortar
- be supported over the cavity.

Fixing methods that penetrate the DPC should be designed to ensure weathertightness. This can be achieved by extending the lower DPC under the bracket, and installing the next section of the DPC over it to create a lap that covers the fixing point.



Where GRP copings are used, they should:

- be fixed in accordance with the manufacturer's instructions
- include a DPC
- allow for normal downward movement in the timber frame.

Further guidance can be found in Chapter 6.2 'External timber framed walls'.

## Valleys and hidden gutters <sup>7.2.21</sup>

**Valleys shall have suitable weathering details, including flashings, to resist the passage of moisture to the inside of the building.**

Valleys, and the components used, should:

- be in accordance with the design
- have a finished pitch which complies with the minimum recommended for the roof
- be fixed in accordance with the manufacturer's recommendations
- small cut tiles should be avoided
- have a lead flashing (minimum code 4) or other suitable saddle flashing, at the head of each valley
- be formed using either preformed GRP, valley coursing tiles (plain tiles), valley trough tiles (interlocking tiles), non-ferrous metal or a proprietary system to Technical Requirement R3.

Where the roof covering is slate or plain tiles, the following may be used:

- A laced valley.
- A swept valley.
- A mitred valley with soakers.

### Valleys using valley tiles

Where valleys are formed using valley tiles:

- purpose-made valley coursing tiles should be used where the roof uses plain tiles
- purpose-made valley trough tiles should be supported by gutter boards where the roof uses single lap interlocking tiles
- they should be mechanically cut to the correct rake
- adjacent coverings should be neatly cut to form a smooth junction, and preferably be cut from tile-and-a-half tiles
- they should be bedded in mortar with a minimum 100mm wide channel (minimum 125mm for pitches below 30°).



### Lead-lined valleys

For lead-lined valleys, the tiles should be cut and bedded as for valley tiles, except that the mortar should be bedded on an undercloak (to prevent direct contact between the lead and the mortar). Mortar should not bridge the welt detail.

Lead should be:

- either code 4 (colour-coded blue) or code 5 (colour-coded red)
- supported on gutter boards of 19mm exterior grade ply, or as specified in the design
- laid in strips no longer than 1.5m
- lapped by a minimum of 150mm, where pitches are above 30°.

### Proprietary gutter or valley systems

Proprietary gutter or valley systems should be in accordance with the manufacturer's recommendations, and securely fixed to suitable supports (exterior grade materials should be used).

## Drainage <sup>7.2.22</sup>

### Roof drainage shall adequately carry rainwater to a suitable outlet.

Drainage should be:

- provided where roofs are greater than 6m<sup>2</sup>; however, consideration should be given to providing drainage to smaller roofs such as dormer, porch roofs and balconies (see Clause 7.1.12)
- of a sufficient size to accommodate normal rainfall, and sized to cope with concentrated flows, i.e. where there are dormer roofs
- designed and fitted to prevent erosion of the lower surface, where water from a large roof surface discharges onto another surface
- fixed in accordance with the design, using the correct type of fittings for internal and external angles, outlets etc. to ensure efficient drainage of the roof
- supported and jointed in accordance with the manufacturer's recommendations
- insulated when passing through a home, in accordance with Chapter 8.1 'Internal services'
- installed ensuring gutters are provided with stop ends, and are laid with a sufficient fall towards the outlet, unless designed to be flat.

Where gutters are behind parapet walls, a suitably sized overflow should be provided.

Where a downpipe discharges above ground level, or above a drainage gully, the downpipe should be fitted with shoes.

## Fascias and trim <sup>7.2.23</sup>

*Also see: Chapter 3.3*

### Fascias, bargeboards and soffits shall be appropriately fixed and treated against decay.

**Table 14:** Materials acceptable for fascia boards

Exterior grade plywood	BS EN 636 Class 3
High density fibre reinforced calcium silicate board	BS 3536
Glass fibre reinforced cement (GRC) board	BS 3536
Proprietary products	Technical Requirement R3

When installing fascia boards and soffits:

- timber for external feature work should be free from waney edges, large knots, resinous pockets, splits and other unsightly defects
- timber for fascias, bargeboards and soffits should be pretreated with preservative
- where preservative treated timber is cut or planed, preservative should be applied to the cut edge
- where timber is to be painted, it should be knotted and primed on all surfaces before fixing
- where timber requires a stained finish, one coat of stain should be applied before fixing
- each joint should be cut and fixed neatly.

Fascia boards should be fixed:

- twice to each rafter
- with splayed butt joints.

# Internal services

## CHAPTER 8.1

This chapter gives guidance on meeting the Technical Requirements for internal services, including:

- the supply of hot and cold water
- plumbing
- gas
- electrical installations.

8.1.1	Compliance	01
8.1.2	Provision of information	01
8.1.3	Water services and supply	01
8.1.4	Cold water storage	03
8.1.5	Hot water service	03
8.1.6	Soil and waste systems	04
8.1.7	Electrical services and installations	05
8.1.8	Gas service installations	06
8.1.9	Meters	06
8.1.10	Space heating systems	07
8.1.11	Installation	07
8.1.12	Extract ducts	09
8.1.13	Testing and commissioning	10



Raising Standards. Protecting Homeowners

### Compliance <sup>8.1.1</sup>

*Also see: Chapter 2.1*

**Internal services shall comply with the Technical Requirements and take account of service entries, ground hazards and chemical attack.**

Internal services which comply with the guidance in this chapter will generally be acceptable.

Adequate precautions against ground hazards and the entry of gas i.e. radon or gas, from landfill sites, should be provided as necessary. Further guidance can be found in BRE Report 211 'Radon: guidance on protective measures for new dwellings', and BRE Report 212 'Construction of new buildings on gas-contaminated land'.

### Provision of information <sup>8.1.2</sup>

**Designs and specifications shall be produced in a clearly understandable format, include all relevant information and be distributed to the appropriate personnel.**

Clear and fully detailed drawings should be available on site to enable work to be carried out in accordance with the design. Designs should be issued to site supervisors, relevant specialist subcontractors and suppliers, and include the following information:

- Location of sanitary fittings.
- Drainage runs.
- Location and size of water storage cisterns and cylinders.
- Hot and cold water pipe runs.
- Central heating pipe runs.
- Underfloor heating pipe runs.
- Gas supply pipe runs.
- Electrical outlets, switches and consumer units.

### Water services and supply <sup>8.1.3</sup>

*Also see: water regulations and guides, BS EN 806*

**Water services shall be based on the pressures and flow rates supplied from the incoming main. Components shall be selected and installed to ensure satisfactory service for the life of the system, with suitable precautions taken against corrosion and damage. Issues to be taken into account include:**

- a) suitability of materials and components
- b) adequate supply
- c) durability
- d) protection from the cold.

#### Suitability of materials and components

Relevant standards for materials and components used in domestic water systems include:

<b>BS EN 806</b>	'Specifications for installations inside buildings conveying water for human consumption'.
<b>BS 7206</b>	'Specification for unvented hot water storage units and packages'.
<b>BS EN 1057</b>	'Copper and copper alloys. Seamless, round copper tubes for water and gas in sanitary and heating applications'.
<b>BS 1566</b>	'Copper indirect cylinders for domestic purposes'.
<b>BS 3193</b>	'Specification for copper hot water storage combination units for domestic purpose'.
<b>BS 7291</b>	'Thermoplastics pipes and fittings systems for hot and cold water for domestic purposes and heating installations in buildings'.

#### Adequate supply

The design and installation of the water services supply should:

- be in accordance with building regulations, statutory requirements and the recommendations of the water supplier
- ensure drinking water is provided at the kitchen sink direct from the supply pipe or, where this is impracticable, from a storage cistern containing an adequate supply of drinking water
- be based on a minimum 1.5 bar dynamic pressure at the stop valve inside the home
- ensure a minimum 20L/min flow rate is available at the stop valve inside the home
- account for pressure and flow rate reductions (a wider supply pipe may be required inside the home)
- account for pressure fluctuations and surges, which may occur within the system and potentially damage fittings (surge arresters may be required)
- ensure that stop valves within the curtilage and outside the home are protected by a shaft or box
- ensure service pipes are a minimum of 750mm below the ground surface – where this is not possible, adequate precautions should be taken against frost and mechanical damage
- ensure that underground ducts are sealed at both ends to prevent the entry of fluids, vermin and insects
- be of materials which are safe and minimise the risk of corrosion
- be in accordance with the recommendations of the water supplier, including compatibility of the supply with the materials and fittings.

The water system should be capable of being drained (hot and cold services separately).

**Durability**

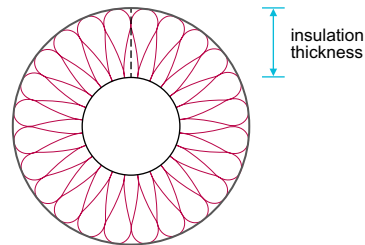
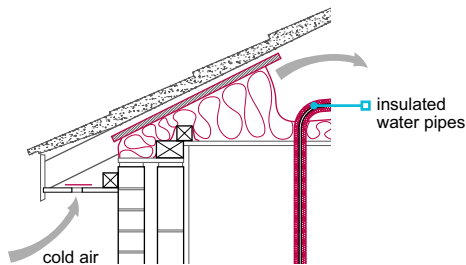
The hot and cold water service should be installed using corrosion resistant pipes and fittings.

In areas where pitting corrosion of copper cylinders occurs, it may be necessary to fit aluminium protector rods. These should be fitted during manufacture in accordance with the relevant British Standard. Sacrificial anodes should be installed where required by the water supplier.

**Protection from the cold**

To reduce the risk of freezing, water services should be located in the warm envelope of the home. Where they are located in unheated spaces, they should be insulated and not affected by cold. Insulation should be provided:

- around water services, including pipework (in accordance with Tables 1 and 2), cisterns and vent pipes (particular care is needed around bends and junctions, especially near openings to the outside air, such as eaves)
- as specified in the design (but not beneath a cold water tank)
- on each side of raised tanks in unheated roof spaces
- in accordance with BS 6700.



**Table 1:** Minimum insulation thickness to delay freezing inside domestic premises for cold water systems

Outside pipe diameter (mm)	Minimum insulation thickness (mm)			
	Thermal conductivity of material at 0°C W/(mK)			
	0.025	0.030	0.035	0.040
15	30	45	70	91
22-28	12	15	19	24

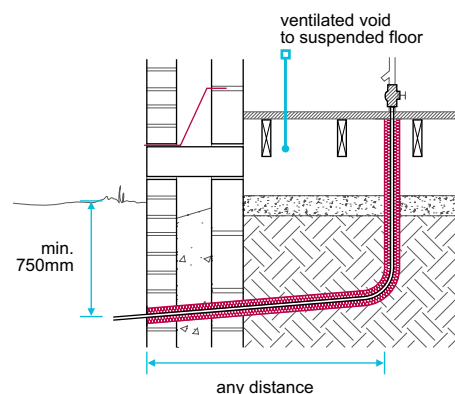
The conditions assumed for the table are:

- air temperature -6°C
- ice formation 50%.
- water temperature +7°C

**Table 2:** Examples of insulating materials:

Thermal conductivity W/(mK)	Material
Less than 0.020	Rigid phenolic foam.
0.020-0.025	Polyisocyanurate foam and rigid polyurethane foam.
0.025-0.030	PVC foam.
0.030-0.035	Expanded polystyrene, extruded polystyrene, cross-linked polyethylene foam, expanded nitrile rubber and improved polyethylene foam.
0.035-0.040	Standard polyethylene foam, expanded synthetic rubber and cellular glass.

Where the floor is of suspended construction, the underfloor water service should be insulated as it passes through the ground and the ventilated space.



### Cold water storage <sup>8.1.4</sup>

**Cold water service shall be provided in accordance with statutory requirements and be adequate.**

Cold water storage should be provided with suitable capacity and include primary feed cisterns where indirect water heating systems are installed. Cold water storage should be provided:

- to supply an open vented hot water storage system (where required by the water supplier)
- to supply cold water outlets (where not connected to the mains supply).

Cisterns should:

- be accessible for inspection and maintenance
- be protected by a rigid close-fitting cover (non-airtight) that also excludes light and insects
- have holes neatly formed with a cutter in the positions shown in the design
- be suitably supported.

BS 6700 provides the following recommendations:

- Storage capacity for small homes – only cold water fittings – 100-150L.
- Storage capacity for small homes – supplying hot and cold outlets – 200-300L.
- Storage capacity for larger homes – 100L per bedroom.

Warning and overflow pipes:

- should be provided at each cold water cistern, to a suitable external discharge, unless permitted by water regulations where it may be internal if it is conspicuous
- should be adequately sized (19mm minimum)
- should be situated 25mm from the shut-off water level in the cistern
- may dip below the water level in accordance with water regulations, terminate vertically downwards or be fitted with a horizontal tee where it discharges.

The cistern bottom should be continuously supported by materials such as:

- softwood boarding
- marine plywood
- chipboard type P5 to BS EN 312
- oriented strand board type OSB3 to BS EN 300, laid with the stronger axis (as marked on board) at right angles to the bearers.

Access should:

- be provided to the main roof space and voids that contain cisterns and tanks, etc. (not required to roof spaces containing only water pipes)
- be via an opening (access hatch) with a minimum width of 520mm in each direction
- not be located directly over stairs or in other hazardous locations
- include a minimum 1m<sup>2</sup> platform located for maintenance purposes
- include securely fixed boarded walkways between the opening and the cistern or other permanent equipment (boarding should be securely fixed without compressing the insulation).

### Hot water service <sup>8.1.5</sup>

*Also see: BS 6700*

**Hot water service shall be provided in accordance with statutory requirements and be adequate for the demand and consumption.**

Hot water services should be designed in accordance with Table 3, and:

- the minimum flow rate should be in accordance with the statutory requirements and generally be available; it may be less where the pressure and flow rate of the incoming supply falls below 1.5 bar
- have the design flow rate available at each outlet when the total demand does not exceed 0.3L/s (where simultaneous discharge occurs, the flow rate at individual outlets should not be less than the minimum rate).

**Table 3:** Flow rate and temperature requirements

Outlet	Design flow rate L/s	Minimum flow rate L/s	Supply temperature °C
Bath (from storage)	0.3	0.2	60
Bath (from combi)	0.2	0.15	40
Shower (excluding instantaneous electric showers)	0.2	0.1	40
Wash basin	0.15	0.1	40
Sink	0.2	0.1	60

Hot water storage should comply with the minimum capacity in Table 4 (based on a draw-off temperature of 60°C), and where appliances require greater volumes, the capacity should be increased accordingly.

**Table 4:** Minimum storage requirements

Shower only	Bath only	Bath and shower(s) <sup>(1)</sup>	Two baths
60L	120L	145L	180L

Note  
 1 Maximum of two showers (excludes instantaneous electric showers).

Where systems are heated by off-peak electricity, the storage capacity should be in accordance with the recommendations of the electricity supplier.

Where homes have one bathroom or shower room, the system should be able to provide adequate hot water:

- immediately after the bath has been filled, for tasks such as washing
- for a second bath after 20 minutes.

Instantaneous systems (using combination boilers) produce hot water on demand (generally at lower flow rates than storage systems), and should only be used where:

- simultaneous demand for hot water is limited. Where there are three or more outlets, the design for simultaneous discharge can omit the outlet at the kitchen sink
- storage combination boilers have the capacity as required in Table 4.

Where homes have two or more bathrooms, the system should be able to provide adequate hot water immediately after each of the baths have been filled, for tasks such as washing.

Where a shower is installed, adequate provision should be made to ensure that the outlet temperature of the water is not significantly affected by the use of other hot or cold outlets in the home. This may be achieved by the provision of a thermostatic shower mixing valve, the appropriate design of pipe sizes or dedicated supplies.

Where boilers can control and prioritise hot water outputs:

- storage capacities can be less than the figures in Table 4
- the storage capacity should be in accordance with the manufacturer's recommendations.

Storage systems provide higher flow rates than instantaneous systems, and:

- require a suitable space for the siting of the storage vessel
- where vented, should be provided with an expansion pipe.

Unvented hot water storage systems should be:

- assessed in accordance with Technical Requirement R3, or meet the requirements of BS 7206 and be the subject of third-party certification, e.g. Kitemarking (applies to both the assembled system and components)
- installed by competent installers.

Hot water cylinders should be:

- supported in accordance with manufacturer's recommendations
- installed vertically, unless designed otherwise
- accessible for maintenance
- insulated as specified in the design.

Where an immersion heater is fitted, it should be:

- appropriate for the type of water supplied to the home
- controlled by a thermostat
- located to facilitate replacement
- fitted with an on/off switch.

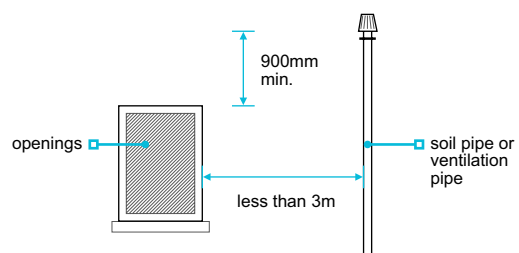
### Soil and waste systems <sup>8.1.6</sup>

Also see: BS EN 752 and BS EN 12056

**Soil and waste systems shall be in accordance with relevant building regulations and installed to ensure that effluent is removed without affecting health or creating unnecessary noise and smell.**

Soil and waste systems should be:

- in accordance with the requirements of the water supplier
- adequately ventilated at the head of underground drains (this may be by a soil pipe or separate ventilation pipe)
- adequately ventilated at each branch
- arranged to ensure foul air from the drainage system cannot enter homes (e.g. ventilated to 900mm above openings when within 3m)
- fixed neatly and securely to provide the correct falls
- fitted to prevent the entry of vermin.

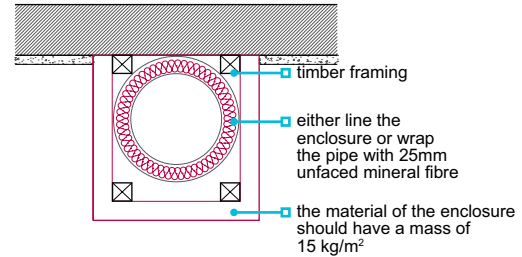


Air admittance valves should:

- be used to allow air to enter the drainage system (but do not avoid the need to ventilate it adequately)
- where used to terminate a soil pipe, comply with BS EN 12380 or be assessed in accordance with Technical Requirement R3
- not be positioned in areas which are liable to freezing
- have free movement of air around them which can be achieved by ventilation grilles, discreet gaps around the boxing or ventilation of the boxing into a ventilated roof void (the ventilation area should be 2500mm<sup>2</sup> minimum unless otherwise specified by the manufacturer)
- where positioned within the home, be accessible for maintenance.

Sound insulation should be provided to soil pipes passing through homes by:

- an encased boxing, using a minimum 15kg/m<sup>2</sup> board material
- wrapping the pipe with a minimum 25mm of unfaced mineral fibre (the insulation should be continued through the thickness of each sound-insulating floor).



Sanitary fittings should be:

- installed with accessories, such as chains and plugs
- secured using non-ferrous or stainless steel screws or fixings appropriate to the weight of item being secured
- fitted without using excessive packing
- fitted to ensure WC lids and seats are stable when open.

Waste disposal units should be:

- provided with adequate support
- fitted with a tubular trap (not bottle or resealing)
- connected to the drainage system in accordance with the manufacturer's instructions.

The junctions of wall tiling with baths and showers should be made watertight using a flexible sealant to accommodate movement. The manufacturer's instructions should be followed.

### Electrical services and installations <sup>8.1.7</sup>

Also see: BRE report 'Thermal insulation: avoiding risks'

**Electrical installations shall be provided in accordance with relevant regulations, codes and standards. The installation shall ensure safe and satisfactory operation and be protected from chemical attack.**

Electrical services and installations should:

- comply with BS 7671 'Requirements for electrical installations'
- comply with BS 6004 'Electric cables. PVC insulated and PVC sheathed cables for voltages up to and including 300/500 V, for electric power and lighting'.
- have fittings and components located in accordance with relevant building regulations
- be installed in accordance with the manufacturer's recommendations
- ensure cables are not placed under, against or within thermal insulation, unless they have been appropriately sized and derated
- ensure PVC covered cables are not in contact with polystyrene insulation.

Rooms should be provided with the minimum number of 13A outlets listed in Table 5 (dual outlets count as two).

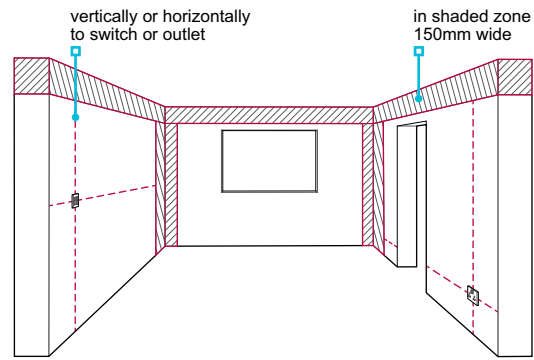
**Table 5:** Minimum number of outlets

Room	Outlets	Notes
Kitchen/utility	8	Where homes have separate areas, the kitchen should have a minimum of four outlets and the utility room four. Where appliances are provided, a minimum of three outlets should be free for general use.
Living or family room	8	A minimum of two outlets near the TV aerial outlet.
Bedrooms	6 (4)	A minimum of six outlets for the main bedroom and a minimum of four outlets for other bedrooms.
Dining room	4	
Landing	2	
Hall	2	

Cables without special protection, such as an earthed metal conduit, should be positioned:

- vertically or horizontally from the outlet or switch being served
- within the shaded zone in the diagram, or
- a minimum of 50mm from the surface of a wall, or a minimum of 50mm from the top or bottom of a timber joist, or batten in a floor or ceiling.

Where the position of switches or sockets can be determined from the reverse side of the wall or partition, the zone on one side of the wall or partition applies to the reverse side.



**Lighting outlets**

Lighting outlets should be provided:

- in each room, hall, landing and staircases
- with two-way switching at each floor level in a staircase

**Cooking spaces**

Cooking spaces should:

- have a minimum 30A supply which is suitably switched and terminated
- have a 13A socket outlet where there is a gas supply

- in the common areas of homes and controlled by either manual switching or automatic light-sensitive controls.

- where provided, have cooker panels located to the side of the cooker space.

**Electrical supply to gas appliances**

Where a gas appliance requires an electrical supply, a suitable fixed spur or socket outlet should be provided.

**TV**

Aerials are not required; however, one of the following should be provided:

- a concealed, coaxial cable from the roof void to a terminal outlet in the main living room
- a conduit and draw wire or suitable alternative.

**Gas service installations 8.1.8**

*Also see: Chapters 6.2, 6.8, BS 5482, BS 6400 and BS 6891*

**Gas service installations shall be adequate and comply with the gas safety regulations, and be in accordance with relevant standards and codes to ensure safe and satisfactory operation.**

Gas service installations should ensure:

- service pipework up to and including the emergency control valve and meter is in accordance with the requirements of the gas transporter, gas supplier and primary meter owner
- installation of pipework and appliances complies with relevant standards and codes including those published by the Institution of Gas Engineers and Managers (IGEM) or Gas Safe Register (GSR)
- where there is a gas supply to the home, a gas point at the cooker space should be provided. This is not required where an electric hob is provided
- where gas pipework is to be installed in timber frame, allowance is made for differential movement.

**Meters 8.1.9**

*Also see: Chapter 6.1*

**Openings in walls for meter cabinets shall be structurally adequate and prevent dampness entering the home.**

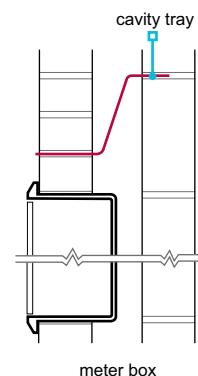
Openings set into external walls should be provided with:

- DPCs and cavity trays
- lintels (except for purpose-designed built-in meter boxes).

Meters and associated equipment should be located to be reasonably accessible and not subject to damage.

Domestic meters may be of the following type:

- Built-in (to the outer leaf of the wall).
- Surface-mounted (on an external wall).
- Semi-concealed (sunk into the ground adjacent to the outer wall).
- Individually purpose-made compartments in accordance with the recommendations of BS 6400.





### Space heating systems <sup>8.1.10</sup>

Also see: Chapter 6.8

**Where space heating is provided, it shall be in accordance with the relevant codes and standards, and ensure safe operation.**

Where appropriate, space heating systems should comply with the following:

<b>BS 5410</b>	'Code of practice for oil firing'.
<b>BS 5449</b>	'Code of practice for central heating for domestic premises'.
<b>BS 8303</b>	'Installation of domestic heating and cooking appliances burning solid mineral fuels'.
<b>BS EN 12828</b>	'Heating systems in buildings. Design for water-based heating systems'.
<b>BSRIA guide BG 4/2011</b>	'Underfloor heating and cooling'.

Space heating appliances, including all components and controls, should be of a type approved by the relevant authority, including:

- Solid fuel – Solid Fuel Association, Heating Equipment Testing & Approval Scheme
- Electricity – British Electrotechnical Approvals Board
- Oil – OFTEC.

The provision of whole home or central heating is discretionary. Where provided, it should be designed in accordance with Table 6, recognised standards, and:

- the number of air changes per hour from kitchens and bathrooms should account for any mechanical ventilation
- where rooms contain open flued appliances, the rate of air change used for the design should be increased in accordance with BS EN 12828
- design temperatures should be verified by calculations and not by performance tests
- the main living room should have a heating appliance or a heat output as part of a whole home heating system
- temperature calculations should be based on a -3°C external temperature.

**Table 6:** Room temperatures and ventilation rates

Room	Room temperature °C	Ventilation rate (air changes per hour)
Living room	21	1.5
Dining room	21	1.5
Bedroom	18	1
Hall and landing	18	1.5
Kitchen	18	2
Bathroom	22	2
Toilet	18	2

### Installation <sup>8.1.11</sup>

**Internal services shall not adversely affect the stability of the home and be installed to ensure satisfactory operation. Issues to be taken into account include:**

- a) fitting of pipes and cables
- b) notching and drilling of joists
- c) concealed services.

#### Fitting of pipes and cables

Services should:

- comply with Chapter 5.1 'Substructure and ground-bearing floors' where they pass through the substructure
- be protected by a sleeve, or ducted, when passing through structural elements and not solidly embedded
- not be located in the cavity of an external wall, except for electricity meter tails
- not be buried in screeds unless permitted by relevant codes of practice.

Where copper pipes are permitted in floor screeds, they should be:

- sleeved or wrapped so that they can move freely along the length and at joints and bends
- jointed with capillary joints.

Pipes should:

- be adequately secured with suitable clips or brackets
- be installed neatly with clips spaced to prevent sagging, but not restrict thermal movement
- have adequate falls (where appropriate)
- be installed with adequate room for thermal expansion and contraction to avoid damage and noise.

Plastic pipework should be wrapped with metallic tape where it is in, or behind, wall surfaces, and would otherwise not be located by a metal detector or similar equipment.

Joints in pipes should be made:

- strictly in accordance with the manufacturer's instructions
- using lead-free flux recommended by the pipe manufacturer, with traces removed immediately after jointing.

Fire stopping should be provided around any services which penetrate fire-resisting floors, walls or partitions. Where a proprietary system, such as an intumescent seal is used, it should be installed in accordance with the manufacturer's instructions.

### Notching and drilling of joists

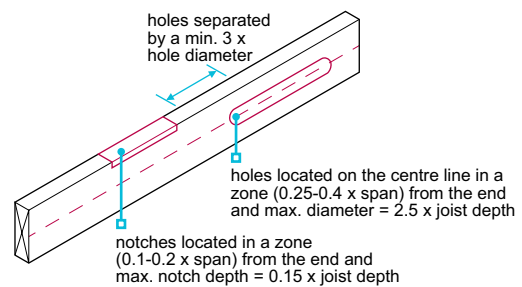
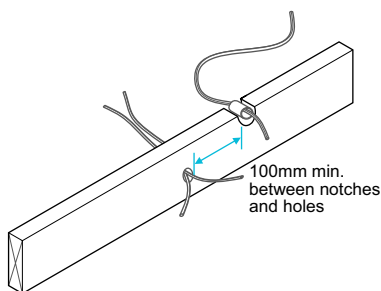
Notching, drilling and chasing to accommodate service pipes and cables should either:

- comply with the clauses below, or
- be designed by an engineer.

### Solid timber and studs

**Table 7:** Limits for notching and drilling solid timber members

	Location	Maximum size
Notching joists up to 250mm in depth	Top edge 0.1-0.2 x span	0.15 x depth of joist
Drilling joists up to 250mm in depth	Centre line 0.25-0.4 x span	0.25 x depth of joist
Drilling studs	Centre line 0.25-0.4 x height	0.25 x depth of stud



Where the structural strength is impaired by notching or drilling, the element should be replaced or correctly repaired.

Holes should be spaced at a minimum of three times the hole diameter.

Notches and holes in the same joist should be separated by a minimum horizontal distance of 100mm.

Instructions should be obtained from the designer when notching and drilling, where:

- the joist is deeper than 250mm, or
- it is close to heavy loads, such as those from partitions, cisterns, cylinders and stair trimming.
- the dimensions are not in accordance with Table 7, or

### I-joists

Preformed holes are provided, and additional holes and notches should not be cut without the approval of the manufacturer.

### Metal web joists

Services should run in the gaps between the metal webs. Conduits may need to be inserted before the joists are fixed in position.

### Lightweight steel

Light weight steel should be used in accordance with Chapter 6.10 'Light steel framed walls and floors'.

### Concealed services

Services concealed in walls or floors should be located so that significant cracking of the surface does not occur. Where chases in walls are necessary, their depth should not exceed:

- 1/6 thickness of the single leaf for horizontal chases
- 1/3 thickness for vertical chases.

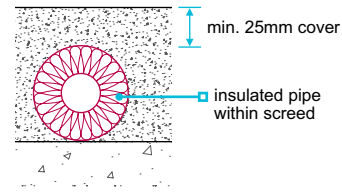
Hollow blocks should not be chased unless specifically permitted by the manufacturer.

Pipes under floor screeds should:

- be protected by wrapping or ducting
- have adequate allowance for thermal expansion, particularly at changes of direction.

Screed cover should be a minimum of 25mm over pipes and insulating material, and:

- where pipes cross, it may be necessary to form a duct to achieve adequate cover



- for in-situ suspended concrete floors, the location and depth of pipes should be approved by the designer.

### Extract ducts <sup>8.1.12</sup>

Also see: Chapter 8.3

**Ductwork to intermittent and continuously running mechanical extract ventilation systems shall ensure satisfactory performance and durability. Issues to be taken into account include:**

- |                            |                 |
|----------------------------|-----------------|
| a) building integration    | d) installation |
| b) resistance to airflow   | e) terminals.   |
| c) control of condensation |                 |

#### Building integration

Routing of ductwork should take account of other building elements. Ductwork passing through structural elements should not adversely affect the structural or fire performance of the building. Where alterations to structural elements, such as I-joists, are required, this should only be carried out in accordance with the manufacturer's recommendations, or be designed by an engineer in accordance with Technical Requirement R5.

The fire requirements of the building should be in accordance with relevant building regulations and standards. Issues that should be taken into account include:

- |   |   |
|---|---|
| ■ suitable detailing of components passing through other elements of the building | ■ the integrity of protected stairs and halls |
| ■ the location and type of dampers and firestops to be used                       | ■ the integrity of walls and floors.          |

#### Resistance to airflow

Ductwork systems should be designed to minimise the resistance to airflow, and be formed from compatible components.

Rigid duct is preferable to flexible, but where flexible duct is used, it should be restricted in length to ensure that the airflow resistance does not prevent the designed ventilation rate from being achieved. Flexible duct should be installed:

- |            |  |
|------------|--|
| ■ straight | ■ in accordance with the manufacturer's recommendations. |
|------------|--|

Bends should generally be formed with proprietary rigid components. Where flexible duct is used to form bends on an intermittent extract system, they should be restricted to a maximum of:

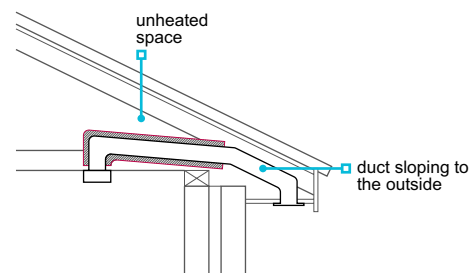
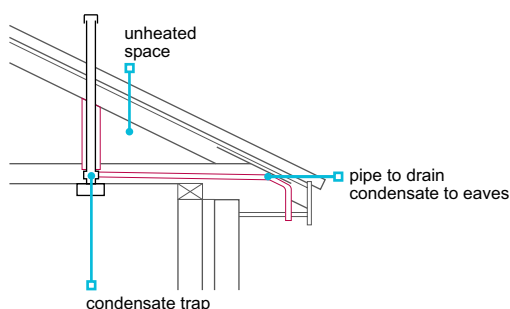
- |                                |   |
|--------------------------------|---|
| ■ two for systems up to 30 L/s | ■ one for extract rates higher than 30 L/s. |
|--------------------------------|---|

#### Control of condensation

Where extract ductwork passes through unheated spaces, it should be continuously insulated to achieve a thermal resistance equivalent to a minimum of 25mm of insulating material with a thermal conductivity of 0.04W/(mK). This can be achieved by using:

- |                                       |                                    |
|---------------------------------------|------------------------------------|
| ■ suitable pre-insulated ductwork, or | ■ a proprietary insulation system. |
|---------------------------------------|------------------------------------|

Alternatively, the ductwork can be fitted with a condensate trap that discharges to the outside or installing the duct to slope to the outside.



## Installation

Ductwork should be installed in a neat and workmanlike manner, be securely fixed, and have:

- adequate support throughout its length
- sealed mechanically fixed joints and connections.

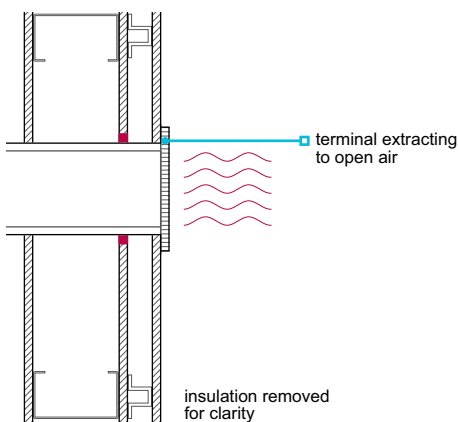
Where ductwork passes through an external wall, it should be positioned to slope slightly outwards to prevent water entering the building. Clips and supports for ductwork should be spaced at equal distances and in accordance with the ductwork manufacturer's recommendations. For rigid ductwork, they should not generally be more than 750mm apart.

Ductwork should not be in direct contact with other surfaces, such as plasterboard ceilings, that may transfer noise to the home.

## Terminals

Ventilation systems should terminate freely to open air.

The air flow resistance of terminals should not adversely affect the performance of the ventilation system. Airflow resistance of terminals can be obtained through testing in accordance with BS EN 13141-2.



## Testing and commissioning <sup>8.1.13</sup>

**Services shall be tested and commissioned to ensure satisfactory operation.**

Services should be tested:

- in accordance with all relevant regulations and codes of practice.
- where pipes are located under screeds (including air or water testing before and after the screed is laid)
- to ensure leaks or other defects are made good prior to the application of finish and handover of the home.

Before completion and handover of the building services should be commissioned in accordance with relevant regulations and codes of practice.

# Low or zero carbon technologies

## CHAPTER 8.2

This chapter gives guidance on meeting the Technical Requirements for low or zero carbon (LZC) technologies.

8.2.1	Compliance	02
8.2.2	Provision of information	03
8.2.3	Clean Air Act	03
8.2.4	System design	03
8.2.5	Access	04
8.2.6	Handling, storage and protection	04
8.2.7	Sequence of work	04
8.2.8	Location	04
8.2.9	Building integration	04
8.2.10	Fixing	05
8.2.11	Electrical installation requirements	06
8.2.12	Pipes, insulation and protection from cold	06
8.2.13	Ground collectors	06
8.2.14	Fuel storage	07
8.2.15	Safe discharge	07
8.2.16	Testing and commissioning	07
8.2.17	Handover requirements	07
8.2.18	Further information	07



Raising Standards. Protecting Homeowners

### Introduction

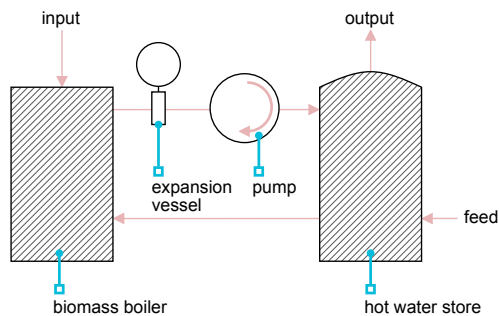
This chapter provides guidance on low or zero carbon (LZC) technologies acceptable to NHBC. Other systems that follow the general principles of this chapter may also be acceptable, subject to specific agreement with NHBC.

Additional requirements for solid fuel and oil fired boilers are given in Chapter 6.8 'Fireplaces, chimneys and flues'. Guidance on other internal services is given in Chapter 8.1 'Internal services'.

This chapter provides guidance on the following technologies:

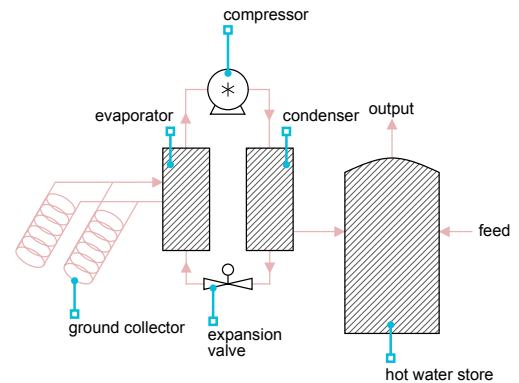
#### Biomass boiler

Systems which burn wood pellets or chips for space and/or water heating.



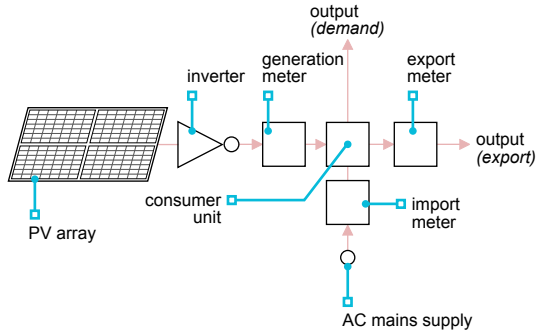
#### Heat pump

Systems which transfer heat from low energy sources. The most common sources are ground, outdoor air and exhaust air.



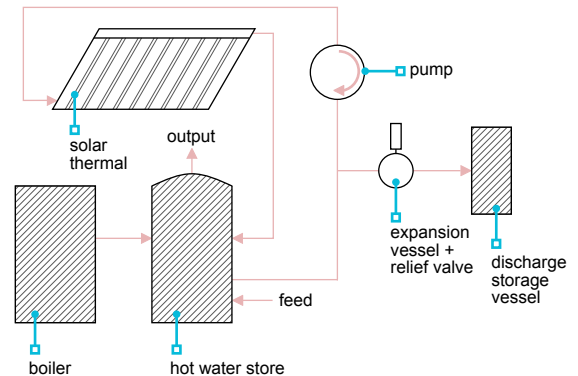
#### Solar photovoltaics (PV)

Systems which convert solar radiation into electricity.



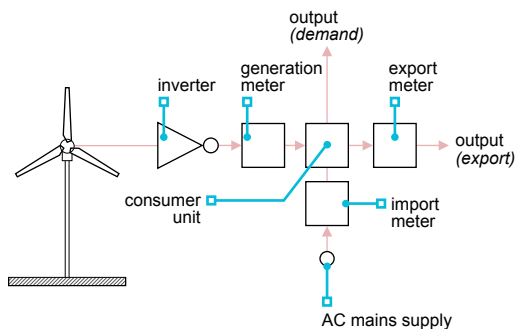
#### Solar thermal water heating

Systems which convert solar radiation energy to space and/or water heating.



#### Wind turbine

Systems which convert wind energy into electricity.



The illustrations provided within the introduction are generic and do not indicate the only possible systems acceptable to NHBC.

## Definitions for this chapter

<b>Controls</b>	Controls are used to operate and/or regulate the system and may be electrical or mechanical.
<b>Exclusion zone</b>	An area where entry is restricted during periods when maintenance is in progress, to prevent risk of injury or loss of life.
<b>Ground collectors</b>	The component of a ground source heat pump system which absorbs heat from the ground. Collectors can be installed either horizontally or vertically in the ground. They may also be incorporated into proprietary foundation systems.
<b>Interstitial condensation</b>	Condensation occurring within, or between, the layers of the building envelope.
<b>Inverter</b>	A device that converts direct current into alternating current.
<b>Islanding (island mode operation)</b>	Where an LZC technology feeds the network or local distribution system during a planned or unscheduled loss of mains supply.
<b>Low or zero carbon (LZC) technologies</b>	A term applied to renewable sources of energy, and also to technologies which are significantly more efficient than traditional solutions, or which emit less carbon in providing heating, cooling or power.
<b>Open loop system stem</b>	A heat pump system that extracts water from an underground source, pumps it through a heat exchanger and returns it underground.
<b>Parallel electrical generation</b>	A system in which building loads can be fed simultaneously from the national grid or electricity supply grid and on-site sources such as wind turbines and photovoltaic panels.
<b>Performance</b>	The manner or quality of functioning for a material, product or system.
<b>Refrigerant pipework</b>	Carries refrigerant between the indoor and outdoor unit of a split system. Normally made of copper and must be insulated and protected from damage.
<b>Renewable energy</b>	Energy from naturally available sources that can be replenished, including energy from the sun, the wind and tides, and from replaceable matter such as wood or other plant material.
<b>Split system</b>	A type of heat pump in which the condenser is located indoors, the evaporator is located outdoors, and the two are linked by refrigerant pipework.
<b>Switchgear</b>	The combination of electrical switches, fuses and/or circuit breakers used to isolate electrical equipment.

## Compliance <sup>8.2.1</sup>

Also see: *Chapter 2.1* and [www.microgenerationcertification.org](http://www.microgenerationcertification.org)

**LZC technologies shall comply with the Technical Requirements. Issues to be taken into account include:**

- a) relevant standards
- b) product certification
- c) operative competency.

LZC technologies that comply with the guidance in this chapter will generally be acceptable.

### Relevant standards

LZC should comply with relevant standards including where applicable:

<b>BS EN 12975-1</b>	'Thermal solar systems and components. Solar collectors'.
<b>BS EN 12976-1</b>	'Thermal solar systems and components. Factory made systems'.
<b>BS EN 61215</b>	'Crystalline silicon terrestrial photovoltaic (PV) modules'.
<b>BS EN 61646</b>	'Thin film terrestrial photovoltaic (PV) modules'.
<b>EN 14511</b>	Parts 1-4 'Air conditioners, liquid chilling packages and heat pumps with electrically driven compressors for space heating and cooling'.
<b>BS EN 61400-1</b>	'Wind turbines'.
<b>BS EN 61400-2</b>	'Wind turbines. Small wind turbines'.
<b>BS EN 14785</b>	'Residential space heating appliances fired by wood pellets'.
<b>BS EN 12809</b>	'Residential independent boilers fired by solid fuel'.
<b>BS EN 303-5</b>	Heating boilers for solid fuels, hand and automatically fired, nominal heat output of up to 300kW. Terminology, requirements, testing and marking.

### Product certification

LZC technologies should have current certification confirming satisfactory assessment by an appropriate independent authority acceptable to NHBC.

Systems, products and installations that are assessed through the Microgeneration Certification Scheme (MCS) will generally be acceptable to NHBC. Certification and test documentation should be made available to NHBC upon request.

Other certification bodies or test documentation may be acceptable where they are considered by NHBC to be a suitable alternative.

### Operative competency

LZC systems should be installed by operatives:

- competent and familiar with the system being installed, and
- certified to a standard acceptable to NHBC.

Installers who have been trained in accordance with the MCS installer standards will generally be acceptable to NHBC.

### Provision of information <sup>8.2.2</sup>

**Designs and specifications shall be produced in a clearly understandable format, include all relevant information and be distributed to all appropriate personnel.**

Design and specification information should be issued to site supervisors, relevant specialist subcontractors and suppliers, and include the following information:

- Indication of which manufacturer and/or installer is responsible for each system and interface.
- A full set of current drawings.
- Manufacturers' specifications.
- Fixing schedule.
- Interface details.
- Specification for controls.
- On-site testing requirements.
- Commissioning schedule.

### Clean Air Act <sup>8.2.3</sup>

**Biomass boilers installed in smoke controlled areas shall comply with relevant legislation.**

Biomass boilers to be installed within a smoke controlled area should comply with the Clean Air Act 1993 or Clean Air (Northern Ireland) Order 1981.

### System design <sup>8.2.4</sup>

**LZC technologies shall be designed to ensure satisfactory performance. Issues to be taken into account include:**

- a) location
- b) acoustics
- c) systems
- d) compatibility
- e) performance.

LZC technologies should be designed in accordance with the manufacturer's recommendations, certification scheme requirements and appropriate standards.

#### Location

The design and location of LZC technologies should take account of factors such as orientation, roof pitch and shading.

For stand-alone wind turbine systems, suitable exclusion zones should be provided in accordance with the manufacturer's recommendations and geographical location.

#### Acoustics

Design and location should take account of:

- internal and external noise
- vibration
- the effect on neighbouring properties, particularly the positioning of the LZC technology in relation to openings.



## Systems

Each system should generally be supplied from one manufacturer as a package and not as individual components or materials. However, where components from more than one manufacturer are used, they should be compatible to ensure satisfactory performance.

## Compatibility

LZC technologies should be installed so as not to adversely affect the performance of the building to which they are fixed, and in accordance with the manufacturer's recommendations.

Multiple systems should be compatible with each other.

## Performance

LZC technologies designed to contribute towards space and water heating should be designed in accordance with the performance requirements in Chapter 8.1 'Internal services'.

## Access <sup>8.2.5</sup>

**Appropriate arrangements shall be provided for the purposes of cleaning, inspection, maintenance and repair of LZC technologies.**

Safe access should be provided to the LZC technologies, including switchgear, inverters, meters and controls. This is to enable the cleaning, inspection, maintenance and repair of systems. Access should be provided in accordance with the manufacturer's recommendations.

## Handling, storage and protection <sup>8.2.6</sup>

**Materials, products and systems shall be handled, stored and protected in a satisfactory manner to prevent damage, distortion, weathering and degradation.**

LZC technologies should be:

- transported, lifted, handled and stored in accordance with the manufacturer's recommendations
- delivered in sequence to avoid storage
- protected to avoid the risk of damage.

## Sequence of work <sup>8.2.7</sup>

**LZC technologies shall be installed in accordance with a suitable schedule.**

To ensure performance, certain LZC systems and ancillary components should be installed in a logical and timely sequence in accordance with the manufacturer's recommendations.

## Location <sup>8.2.8</sup>

**LZC technologies shall be correctly located.**

LZC technologies, including ancillary components should be located and identified in accordance with the manufacturer's recommendations.

## Building integration <sup>8.2.9</sup>

**LZC technologies shall be securely fixed and not adversely affect the weather resistance of the building.**

Foundations and anchor points for stand-alone LZC technologies should be designed by an engineer in accordance with Technical Requirement R5 to withstand the structural forces acting upon them.

The structure to which the LZC technology is attached should be assessed according to its ability to accept the loadings and prevent detrimental effects arising from movement or vibration. The design of the structure should take account of:

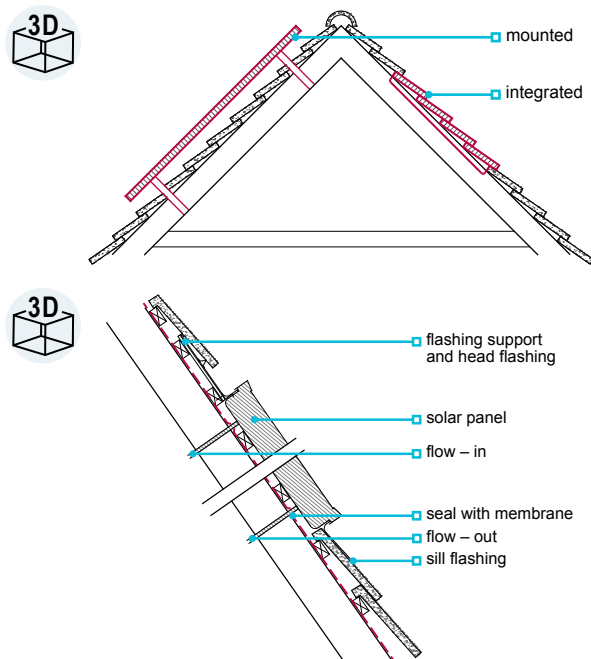
- the self-weight of the LZC components
- imposed loads
- wind loads
- snow loads
- dynamic loading (where relevant).

Notching, drilling or chasing of structural components to accommodate service pipes or cables should either comply with Chapter 8.1 'Internal services', or be designed by an engineer in accordance with Technical Requirement R5.

Fixings, supports, bracketry and mounting frames should:

- accommodate all static and dynamic loads in accordance with the manufacturer's recommendations
- be designed to take account of ventilation and drainage requirements of the LZC technology
- have adequate protection against corrosion.

Where two metals are to be joined, they should either be compatible or isolated, to prevent bimetallic corrosion. Aluminium and aluminium alloys should not come into contact with cementitious material.



All interfaces between the LZC technology and the building should ensure adequate weather resistance, sealed to limit air leakage and prevent moisture from reaching the interior or any part of the structure that could be adversely affected by its presence. The envelope should be weatherproofed using appropriate flashings and fixings. Weatherproofing details that rely solely on sealant are not acceptable. Flashings should be formed from the materials listed in Table 1.

**Table 1:** Materials for flashings

Flashing material	Guidance
Rolled lead sheet	Minimum code 4. BS EN 12588.
Aluminium and aluminium alloys	BS EN 485 and BS EN 573, 0.6-0.9mm thick and protected from contact with mortar by a coating of bituminous paint.
Zinc alloys	BS EN 988 and 0.6mm thick.
Copper	BS EN 1172 0.55mm thick and fully annealed. Where two metals are to be joined, they should be compatible and not cause bimetallic corrosion in that environment Alternatively, they should be isolated from each other.
Proprietary flashing, including plastic and composite.	Assessed in accordance with Technical Requirement R3.

To avoid potential surface or interstitial condensation, the design should take account of thermal bridging, particularly where any part of the system, including fixings, penetrates the thermal envelope.

### Fixing <sup>8.2.10</sup>

*Also see: Chapter 2.1*

**LZC technologies shall be fixed using durable materials.**

Fixings should comply with the types listed in Table 2.

**Table 2:** Materials suitable for fixings

Fixing material	Guidance
Phosphor bronze	NA
Silicon bronze	NA
Stainless steel	BS EN ISO 3506
Mild steel	Coatings to BS EN 12329, BS EN ISO 2082, BS EN 1461, or other appropriate treatment in accordance with BS EN ISO 12944 or BS EN ISO 14713.
Aluminium alloy	BS EN 573 and BS EN 755
Stainless steel	BS EN 10088
Mild steel	BS EN 10346
Other materials	Assessed in accordance with Technical Requirement R3.

Materials that comply with recognised standards, which provide equal or better performance to those above, are also acceptable.

The type, size, number, position and fitting tolerance of fixings should be in accordance with the manufacturer's recommendations. Issues that should be taken into account include:

- the provision of suitable locking nuts and washers
- the isolation of aluminium from cementitious material.
- the isolation of dissimilar metals

### Electrical installation requirements <sup>8.2.11</sup>

**The electrical installation shall be in accordance with relevant regulations.**

Electrical installations should comply with BS 7671 'Requirements for Electrical Installations'.

Where parallel electrical generation occurs, inverters should have a current Engineering Recommendation G83/1 type test certificate and comply with all other parts of ER G83/1 for standard installations. Larger installations should comply with ER G59/2.

The electrical installation should be capable of being isolated from all other electrical sources when required, for maintenance or testing.

LZC technologies which generate electricity and are connected to the mains should automatically disconnect when there is a mains power failure. This is to prevent them from feeding the network or local distribution system during a planned or unscheduled loss of mains supply. This is known as 'islanding'.

### Pipes, insulation and protection from cold <sup>8.2.12</sup>

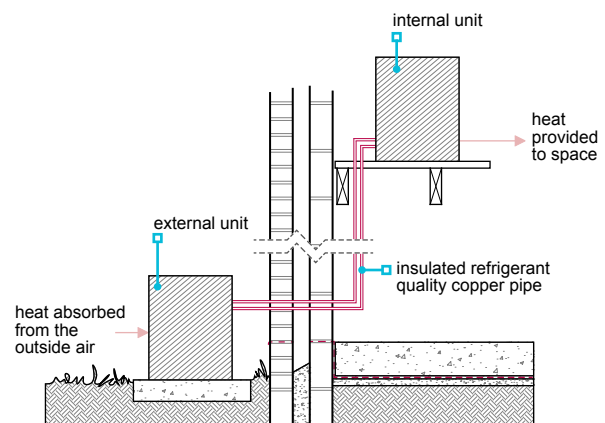
**All pipework and insulation, including refrigerant pipework, shall ensure adequate performance and be designed to prevent freezing.**

Materials used for pipes and insulation should be suitable for the intended purpose and provide satisfactory performance for the life of the system. Pipes should comply with relevant codes and standards or be independently assessed for their intended use in accordance with Technical Requirement R3. Insulation materials should be inert, and durable, and should not be adversely affected by moisture or vapour. They should also comply with relevant codes and standards or be independently assessed for their intended use in accordance with Technical Requirement R3.

Where there is a risk of pipes freezing, they should be insulated, particularly when at, or close to, ground level.

Refrigerant pipework connecting split systems should be of refrigerant quality copper pipe or other material as recommended by the manufacturer. The pipe should be insulated, and the insulation should incorporate a vapour control layer to prevent ice build-up.

Air source systems should incorporate an automatic defrost cycle and suitable condensate drainage.



### Ground collectors <sup>8.2.13</sup>

**The installation of ground collectors shall take structural and environmental factors into account.**

The depth and layout of ground collectors should be specified to avoid freezing of adjacent ground. Where open loop systems are proposed, consultation with the appropriate environment agency should be made and may require one or more of the following:

- A licence to investigate groundwater.
- A discharge consent.
- An abstraction licence.

Excavations for the installation of ground collectors should not adversely affect aquifers, foundations, drainage, water supply pipes and other services. Design should take account of local planning authority guidance, including excavations that are close to trees and hedgerows.

Ground collectors should be protected and tested prior to backfilling.

### Fuel storage <sup>8.2.14</sup>

*Also see: The HVCA Guide to Good Practice Installation of Biofuel Heating (TR/38)*

#### Fuel storage for biomass boilers shall be suitable for the installation.

Fuel stores should have appropriate:

- access for delivery
- fire detection and extinguishing equipment where elevated dust levels are expected
- volume to take account of peak load and period of demand
- fire resistance and separation to prevent fire and gases entering other parts of the building.

### Safe discharge <sup>8.2.15</sup>

#### Discharge from LZC technologies shall terminate safely.

Solar thermal water heating systems should discharge into a storage vessel. The discharge pipework and vessel should be suitable to withstand high temperatures.

### Testing and commissioning <sup>8.2.16</sup>

#### LZC technologies shall be tested and commissioned in accordance with the commissioning schedule.

The installer should check that the system is in accordance with the certification requirements, the manufacturer's recommendations and the design. Issues to be taken into account include:

- the safety of the system
- the correct installation of the system
- the correct operation of the system.

Upon completion, the installer should provide a certificate to confirm that the LZC technology has been installed, tested and commissioned in accordance with the above.

### Handover requirements <sup>8.2.17</sup>

#### Detailed information and instructions shall be provided to the homeowner.

The pack of information provided to the homeowner should include:

- user instructions for the systems installed
- contact details for the manufacturer and installer
- key components installed
- a completed manufacturer's certificate from an acceptable independent assessment organisation, MCS or suitable alternative
- a completed installer's certificate from an acceptable independent assessment organisation, MCS or suitable alternative
- details of the fuel type and source
- maintenance and servicing requirements
- warranties and/or guarantees for the LZC technology.

### Further information <sup>8.2.18</sup>

- *BRE Digest 489*
- *BRE Digest 495*
- *British Wind Energy Association*
- *BS EN 12975-2: 2006*
- *BS EN ISO 14713: Part 1-4*
- *CE72*
- *CE131*
- *ER G59/2*
- *ER G83/1*
- *Photovoltaics in buildings.*

# Mechanical ventilation with heat recovery

## CHAPTER 8.3

This chapter gives guidance on meeting the Technical Requirements for mechanical ventilation with heat recovery (MVHR) systems acceptable to NHBC.

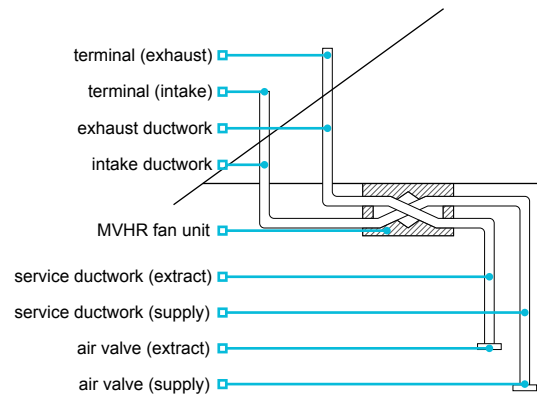
8.3.1	Compliance	01
8.3.2	Provision of information	01
8.3.3	Building integration	01
8.3.4	Noise	02
8.3.5	Design considerations	02
8.3.6	Access and operation	04
8.3.7	Ductwork	04
8.3.8	Fixing and jointing of ductwork	04
8.3.9	Commissioning and balancing	05
8.3.10	Handover requirements	05



Raising Standards. Protecting Homeowners

### Definitions for this chapter

<b>Air valve (extract and supply)</b>	Wall or ceiling mounted fittings used to balance the flow rate of air between rooms; may be referred to as grilles.
<b>Exhaust ductwork</b>	Carries air from the fan unit and exhausts it to the external atmosphere.
<b>Intake ductwork</b>	Carries air from the external atmosphere to the MVHR fan unit.
<b>MVHR fan unit</b>	Unit that contains the fan(s), heat exchanger and filter(s).
<b>Service ductwork extract and supply</b>	Carries air between the air valves and the MVHR fan unit.
<b>Terminal fittings</b>	Located on the outside of the building to finish the intake and exhaust ductwork.



### Compliance <sup>8.3.1</sup>

*Also see: Chapter 2.1, Approved Document F, Domestic Ventilation Compliance Guide, Section 3 of the Technical Handbooks, Domestic Ventilation Guide in Scotland and Technical Booklets in Northern Ireland*

**MVHR design, materials and sitework shall comply with the Technical Requirements, and be installed by competent operatives.**

MVHR systems that comply with the guidance in this chapter and are in accordance with the relevant British Standards and building regulations will generally be acceptable.

MVHR systems should be installed by operatives:

- competent and familiar with the system being installed, and
- trained in accordance with the BPEC installer scheme, or other suitable scheme acceptable to NHBC.

### Provision of information <sup>8.3.2</sup>

**Designs and specifications shall be produced in a clearly understandable format, include all relevant information and be distributed to the appropriate personnel.**

Designs and specifications should be issued to site supervisors, relevant specialist subcontractors and suppliers, and include the following information:

- Location of all ductwork runs, the fan unit and controls.
- Type, size and position of ducts and terminals.
- Direction of fall for 'horizontal' ductwork.
- Type and spacing of clips and fixings.
- Type and location of ancillary components, including those used for fire safety and acoustic purposes.
- Designed airflow-balancing figures for the system.

### Building integration <sup>8.3.3</sup>

*Also see: Chapter 7.1 and 7.2*

**MVHR systems shall ensure compatibility with other building elements and not adversely affect the performance of the building. Issues to be taken into account include:**

- a) weathertightness
- b) fixing of fan units
- c) firestopping.

#### Weathertightness

Proprietary roof terminals should be used to ensure the weathertightness of the roof covering.

#### Fixing of fan units

MVHR fan units should only be fixed to parts of the building capable of taking the load. Where MVHR fan units are supported by framed structures, additional components such as noggings may be required to provide a secure fixing point.

Fan units should be located, orientated and fixed in accordance with the design, using the clips, brackets and fixings recommended by the manufacturer.

### Firestopping

The MVHR system should not adversely affect the fire performance of the building. Issues to be taken into account include:

- ensuring that the fire requirements of the building are in accordance with relevant building regulations
- suitable detailing of components passing through other elements of the building
- location and type of firestops to be used
- integrity of protected stairs and halls
- integrity of walls and floors.

Proprietary fire components should be suitably tested, and specified to take account of the test conditions.

Relevant standards include:

<b>BS 476</b>	'Fire tests on building materials and structures.'
<b>BS EN 1365-2</b>	'Fire resistance tests for loadbearing elements. Floors and roofs.'
<b>BS EN 1366-3</b>	'Fire resistance tests for service installations. Penetration seals.'

### Noise <sup>8.3.4</sup>

#### MVHR systems shall be designed to minimise disturbance caused by noise.

MVHR fan units should be sized to run at their optimum speed and to provide suitable performance whilst taking the resulting noise and vibration into account. Specifying MVHR fan units that can provide the required airflow rates when running at less than full speed can reduce unnecessary noise.

Ductwork should be sized to allow air to pass freely without causing excessive noise disturbance. To reduce noise transfer along ductwork, a short length of flexible duct can be installed adjacent to air valves and fan units. Other issues to be taken into account include:

- noise between habitable rooms
- external noise
- location of the MVHR fan unit
- the type of mountings used to secure the MVHR fan unit.

### Design considerations <sup>8.3.5</sup>

*Also see: Chapter 9.1*

#### MVHR systems shall ensure compatibility and satisfactory performance. Issues to be taken into account include:

- a) performance
- b) systemised approach
- c) type and position of air valves and terminals
- d) control of condensation
- e) protection from cold.

### Performance

The MVHR system should be designed to provide satisfactory performance and be installed according to the design and manufacturer's recommendations. Variations from the design should maintain the satisfactory performance of the system and be approved by the designer.

Issues that should be taken into account include:

- ventilation rates as set out in appropriate building regulations and standards
- fan capacity, accounting for airflow resistance of the system
- ensuring the even distribution of airflow, taking into account airflow resistance, including from bends and fittings.

Airflow resistance should be calculated using figures for air valves and terminals determined in accordance with BS EN 13141-2 and data supplied by the duct manufacturer. Ductwork should be as direct as possible to reduce the number of bends.

Allowance should be made for air transfer within the home. Where gaps between the underside of internal doors and the floor finish are used for air transfer, the guidance in Chapter 9.1 'A consistent approach to finishes' should be considered.

### Systemised approach

The MVHR system should be designed as a complete package, taking into account the performance of all components and materials, to ensure compatibility and the performance requirements of the system.

Particular consideration should be given where components from different manufacturers are specified on the same system.

### Type and position of air valves and terminals

Air valves should be selected according to location and function, ensuring appropriate specification for:

- wall or ceiling location
- supply or extract function
- the velocity of the system.

To create cross-ventilation within a room and to ensure satisfactory operation, air valves on low velocity systems should be:

- positioned on the opposite side of the room from internal door openings
- a minimum of 200mm from walls, where located on a ceiling
- a maximum of 400mm from the ceiling, where located on a wall
- a minimum of 600mm (on plan) from hobs in kitchens
- positioned to account for the likely location of tall furniture and to avoid draughts over beds and seating areas
- lockable, where adjustable.

To prevent cross-contamination, intake terminals should generally be separated from exhaust terminals and other potential sources of pollution by a minimum of 1m measured on plan. Increased separation distances may be required between the intake and any:

- soil and vent pipe terminal
- boiler flue outlet
- biomass or solid fuel chimney terminal.

Terminals should prevent the entry of birds and animals.

### Control of condensation

Ductwork should be insulated to prevent condensation formation where:

- it passes through spaces outside the insulated parts of the home, such as a roof void
- carrying cold air through spaces that are within the insulated parts of the home.

This can be achieved by using suitable pre-insulated ductwork, or a proprietary insulation system with a thermal resistance equivalent to a minimum of 25mm of insulating material, with a thermal conductivity of 0.04W/Mk.

Ductwork insulation, including that used for proprietary duct insulation systems and pre-insulated ducts should be:

- inert, durable and suitable for use with the ductwork system
- continuous and vapour resistant
- not adversely affected by moisture vapour
- installed in a neat and workmanlike manner to ensure that there are no gaps
- installed in accordance with the manufacturer's recommendations.

Where a vapour control layer is incorporated, the joints should be sealed using appropriate tapes or sealants as recommended by the manufacturer.

**Table 1:** Ductwork insulation

Type of duct	Ductwork continuously insulated	
	Ductwork located inside the insulated part of the home	Ductwork located outside the insulated part of the home
Intake	Yes	Yes
Exhaust	Yes	Yes
Service (supply and extract)	No	Yes <sup>(1)</sup>

Notes

<sup>1</sup> Additional insulation should be provided to protect the system from the cold.

Any condensate that forms within the fan unit or ductwork should be able to drain to a suitable outfall. Fan units should be located to enable connection of the condensate drain to the soil and waste system via a dry trap.

### Protection from cold

MVHR systems should be protected from the effects of cold. Issues to be taken into account include:

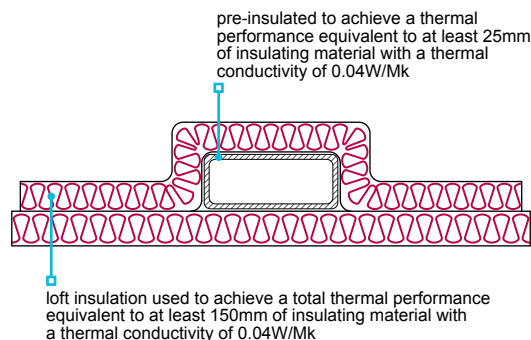
- performance in relation to indoor air quality
- the manufacturer's recommendations where any parts are located outside the insulated part of the home
- insulation of ductwork and other system components.

To prevent damage to the components and ensure satisfactory operation, MVHR systems should be fitted with automatic frost protection.



Horizontal sections of service ductwork, outside the insulated parts of the home, should be insulated to achieve a thermal resistance equivalent to at least 150mm of insulating material with a thermal conductivity of 0.04W/Mk. This may be achieved by installing the ductwork between the layers of horizontal insulation.

Condensate drains located outside the insulated part of the home should be insulated to prevent freezing.



### Access and operation <sup>8.3.6</sup>

**MVHR systems shall be designed and installed to ensure that the fan unit and associated controls are easily accessible.**

**Table 2:** Guidance for the suitable functioning of, and access to, the MVHR system

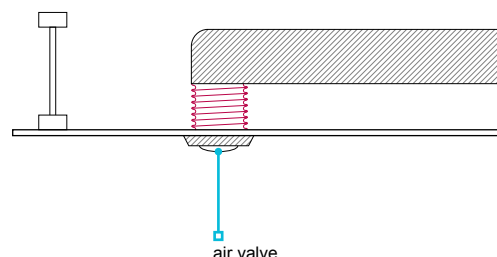
	Fan unit located inside the insulated part of the home	Fan unit located outside the insulated part of the home
<b>Access</b>	Access should not be obstructed and panels should be located and sized to enable routine servicing to be carried out.	A safe means of access, including a suitable walkway and a working platform 1m <sup>2</sup> immediately adjacent to the MVHR fan unit, should be provided. The walkway and platform should be designed to ensure the continuity of any insulation, and the supporting structure should be designed to take account of the additional load.
<b>Control and functionality</b>	Where a 'boost' function is provided, it should switch off automatically and be located in, or adjacent to, the room it serves. Where a 'summer bypass' function is provided, it should operate automatically and divert the airflow around the heat exchanger. The MVHR system should be capable of being isolated by a switched fused spur.	
<b>Indication and controls</b>	MVHR systems should include visual indicators showing maintenance and servicing requirements, and mode of operation. These should be visible from within the insulated envelope, not obscured from view, and be simple to use.	
<b>Cleaning</b>	To maintain operating performance, extract service ductwork and air valves should either be fitted with filters, or ductwork should be accessible for cleaning.	

### Ductwork <sup>8.3.7</sup>

**Ductwork design and the materials used should be suitable for the intended purpose and not adversely affect the performance of the building.**

Ductwork should:

- provide satisfactory performance for the life of the system
- be routed as directly as practicable
- be of a rigid or semi-rigid material suitable for use in MVHR systems
- be fixed in accordance with the manufacturer's recommendations.



Bends, connections and junctions should be formed using proprietary components that are part of the ductwork system.

Flexible ducting should:

- only be located adjacent to fan units or air valves
- not be used to form bends.
- not be more than 300mm in length

Where ductwork routes require alterations to structural elements, these should be in accordance with the manufacturer's recommendations or in accordance with Technical Requirement R5.

### Fixing and jointing of ductwork <sup>8.3.8</sup>

**MVHR ductwork and insulation shall be installed to a satisfactory standard. Issues to be taken into account include:**

- a) fixing
- b) jointing.

Ductwork should be securely installed in a neat and workmanlike manner.

### Fixing

Parallel ductwork runs should be positioned to maintain a reasonably even gap.

To prevent condensate collecting, horizontal ductwork should be to a suitable outfall in accordance with the design, and installed to a true line to avoid localised dips.

Where ductwork passes through an external wall, it should be positioned to slope slightly outwards to prevent water entering the building.

Ductwork should be securely held in position by evenly spaced clips no more than 750mm apart, or in accordance with the ductwork manufacturer's recommendations.

Ductwork should not be in direct contact with other surfaces, such as plasterboard ceilings, that may transfer noise to the home.

### Jointing

The method and materials used for jointing ductwork should be specified by the duct manufacturer, and be:

- durable and airtight
- sealed with purpose-designed connections in accordance with the manufacturer's recommendations.
- securely fixed

Where tapes and sealants are used, they should be suitable for the intended purpose and be recommended by the ductwork manufacturer. Issues to be taken into account in relation to the durability of the jointing method include:

- thermal movement
- temperature
- moisture
- compatibility with the duct material.

Tape should be installed in a neat and workmanlike manner, and surfaces should be dry and free from grease and dust before applying. Excess sealant should not extrude to the inside of the duct.

### Commissioning and balancing <sup>8.3.9</sup>

**MVHR design, materials and sitework shall be tested and commissioned in accordance with the commissioning schedule.**

Upon completion of the installation MVHR systems should be protected from dust during the construction of the home. Where possible the system should be switched off and dust covers applied to air valves.

Prior to completion of the home, the system:

- including ductwork and filters, should be checked to ensure it is clear from dirt and dust that may have accumulated during construction
- should be adjusted by using the air valves and controls to achieve the correct balancing and airflow rates
- should be commissioned to confirm performance
- should have air valves locked in position after correct commissioning and balancing.

Where the system cannot be balanced using the air valves and system controls, the complete system should be checked to ensure that it complies with the design.

Any changes from the design should be referred back to the designer. Adjusting the fan speed above the designed output may result in noise disturbance, and should be avoided.

A copy of the commissioning certificate should be made available to NHBC upon request.

### Handover requirements <sup>8.3.10</sup>

**MVHR systems shall be provided with clear and detailed information and instructions that are handed over to the end user.**

The pack of information should be in a format intended for a non-technical user and include:

- the commissioning certificate
- guidance for the use of summer bypass and boost settings, where installed
- user instructions for the system and its controls
- contact details of the manufacturer and installer
- user-friendly description and explanation of the system, including the location of components
- details of the installed system, including part numbers for consumables
- details of routine maintenance, e.g. changing/cleaning the filters
- details of any maintenance and servicing agreements.
- method of cleaning the ductwork, where required

# A consistent approach to finishes

## CHAPTER 9.1

This chapter gives guidance on meeting the Technical Requirements for finishes in new homes.

9.1.1	Compliance	01
9.1.2	External walls	01
9.1.3	Walls and ceilings	03
9.1.4	Doors and windows	05
9.1.5	Floors	05
9.1.6	Glazing	06
9.1.7	Ceramic, concrete, terrazzo and similar tile finishes	06
9.1.8	Fitted furniture	06
9.1.9	Joint sealants	06
9.1.10	Other surfaces and finishes	07
9.1.11	External works	07



Raising Standards. Protecting Homeowners

### Compliance <sup>9.1.1</sup>

Also see: Chapter 2.1

#### Finishes shall comply with the Technical Requirements.

Finishes that comply with the guidance in this chapter will generally be acceptable.

This guidance:

- is intended to apply when the home is substantially complete and ready for NHBC pre-handover inspection
- will be used by NHBC both during the construction process and when conducting resolutions under section 2 of the Buildmark insurance cover
- should be considered in conjunction with relevant performance standards and guidance contained elsewhere within NHBC Standards
- uses tolerances and finishes considered to be appropriate for the house-building industry and takes precedence over other recommendations
- is not intended to deal with every situation which may arise, and discretion should be exercised.

Some elements may be subject to the effects of normal thermal or drying movement, and this may occur both before and after completion.

Some materials are not uniform and are not intended to be; this includes reclaimed materials. Some colour and texture variation is inevitable; this is often used as an aesthetic feature and should be recognised in appropriate tolerances or considered separately.

The nature and extent of work necessary to remedy minor variations from the tolerances and finishes given should be proportionate and appropriate to the circumstances.

### External walls <sup>9.1.2</sup>

#### External walls shall be built to appropriate tolerances and have an acceptable finished appearance. Issues to be taken into account include:

- |                        |                        |
|------------------------|------------------------|
| a) fairfaced masonry   | e) brick slip cladding |
| b) render              | f) timber cladding     |
| c) curtain walling     | g) tile hanging        |
| d) rainscreen cladding | h) cast stone sills.   |

Tolerances and appearance should be considered:

- for the entire wall (e.g. panels and interfaces), and not for the individual elements of the construction, such as bricks, or design features and details (e.g. quoins, soldier courses and plinths)
- in daylight, and from a minimum distance of 10m.

#### Fairfaced masonry

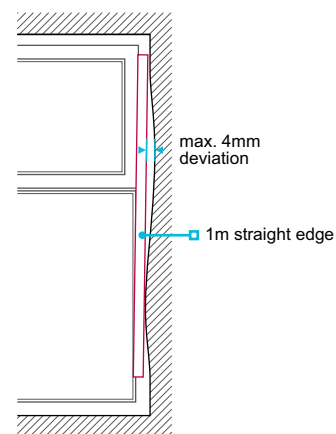
Fairfaced masonry should:

- be reasonably uniform in texture, finish and colour, including mortar
- not have excessive colour banding
- not have significant cracks in the facing bricks or other damage, such as chips and marks greater than 15mm in diameter
- be within a maximum deviation of 4mm over 1m at external reveals.

Where a fairfaced finish can only be achieved on one side (such as half brick walls), the other faces should be left neat and tidy.

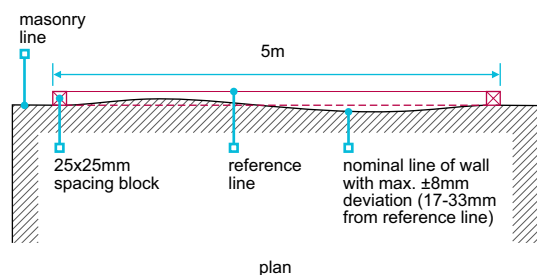
Also note:

- Some mortar blemishes will occur on individual masonry units.
- Some variation will occur in the texture, finish and colour of mortar, in individual masonry units and generally over the wall.
- Efflorescence occurs naturally in some types of masonry. It is not harmful and generally disappears over time.
- Some brick products have features or marks which may be in excess of 15mm in diameter.
- Some minor shrinkage cracking may occur between masonry units (bricks and blocks) and mortar joints.



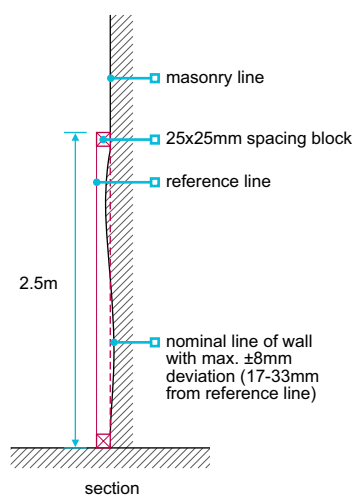
Fairfaced masonry should be:

- adequately straight on plan, with a  $\pm 8\text{mm}$  maximum deviation in any length of wall up to 5m
- adequately straight in section, with a tolerance of  $\pm 8\text{mm}$  per storey height (approx. 2.5m)
- a maximum of 8mm from plumb in any storey height (2.5m storey height)
- a maximum of 8mm from plumb in total for walls up to 5m high
- a maximum of 12mm from plumb in total for walls over 5m high.



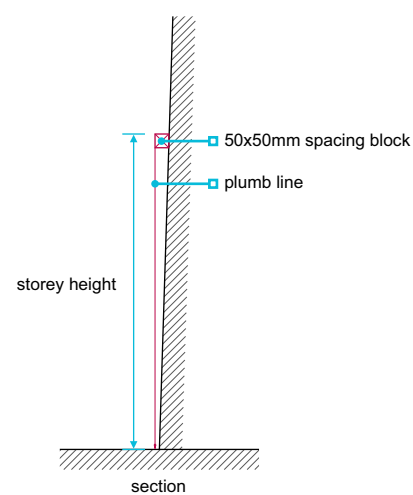
Example:  
Using 25mm wide spacing blocks, the masonry line should be 17-33mm from the reference line.

Spacing block dimensions are a guide and final dimensions should ensure reference line is kept clear of the wall face.



Example:  
Using 25mm wide spacing blocks, the masonry line should be 17-33mm from the reference line.

Spacing block dimensions are a guide and final dimensions should ensure reference line is kept clear of the wall face.

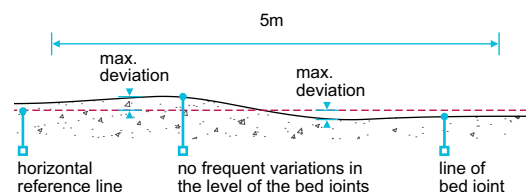


Example:  
Using 50mm wide spacing block, the plumb bob should be 42-58mm from the wall.

Note:  
Spacing block dimensions are a guide and final dimensions should ensure plumb line is kept clear of the wall face.

Bed joints should:

- not have frequent variations in level
- have a maximum deviation of  $\pm 8\text{mm}$ , in walls 5m long (a pro rata tolerance is applicable for walls less than 5m long),
- have a maximum deviation of  $\pm 12\text{mm}$  in walls more than 5m long.



The thickness of an individual bed joint should not vary from the average of any eight successive joints by a maximum of 5mm.

The vertical alignment of perpend joints should not deviate significantly from the perpendicular. As bricks can vary in length, not all perpend joints will align; however, there should not be a cumulative displacement of the perpend joints in a wall.

## Render

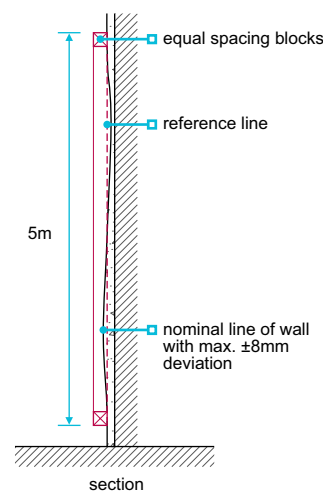
Also see: Chapter 6.11

Render should:

- be reasonably consistent in texture, finish and colour
- be flat, within a maximum  $\pm 8\text{mm}$  vertical and horizontal deviation in 5m, though this may increase where render is in close proximity to features
- not have crazing more than 0.2mm wide.

Also note:

- There may be some colour variation in appearance due to differences in suction of the background and orientation of the wall.
- Daywork joints, patching and other repairs may be visible but should not be unduly obtrusive.
- Some hairline cracking and crazing is likely to occur in both traditional render and proprietary render systems. Such cracking and crazing should not impair the performance of the render.
- Areas of render in close proximity to features (e.g. bell casts) are excluded from the tolerance.
- Flatness is measured in a similar way to straightness on plan and plumb of masonry.



Example:  
Using 25mm wide spacing blocks, the masonry line should be 17-33mm from the reference line.

Spacing block dimensions are a guide and final dimensions should ensure plumb line is kept clear of the wall face.

### Curtain walling

Curtain walling should be within:

- reasonable tolerances and appearance for the materials
- a maximum deviation of  $\pm 2\text{mm}$  in any storey height or structural bay width, and  $\pm 5\text{mm}$  overall, unless otherwise specified in the design.

### Rainscreen cladding

Rainscreen cladding should be within:

- reasonable tolerances and appearance for the materials
- a maximum deviation of  $\pm 3\text{mm}$  in any storey height or structural bay width, unless otherwise specified in the design.

### Brick slip cladding

Brick slip cladding should be within:

- reasonable tolerances and appearance for the materials
- $\pm 8\text{mm}$  maximum vertical and horizontal deviation from flatness in 5m
- a tolerance of  $\pm 8\text{mm}$  maximum deviation for each 5m section of wall for bed joints (a pro rata tolerance is applicable for walls less than 5m long).

### Timber cladding

Variation in colour may occur in uncoated timber exposed to the weather, and the rate and extent may vary.

Also note:

- The effects of normal weathering may cause certain uncoated timber, over time, to develop a silver/grey colour.

### Tile hanging

Panels should be reasonably uniform in appearance, particularly at abutments, and may vary in colour and size depending on the manufacturing process.

### Cast stone sills

Surface abrasions and chips which occur on site should be removed in accordance with the manufacturer's recommendations, which may include filling, polishing out, respraying or painting as appropriate.

Also note:

- Cast stone is manufactured with natural products and colour variations are inevitable.
- Efflorescence, fungicidal growth and colour variation may occur due to orientation, shading and pollution.

## Walls and ceilings <sup>9.1.3</sup>

**Walls and ceilings shall be built to appropriate tolerances and have an acceptable finished appearance.**

**Issues to be taken into account include:**

- a) plastering and dry lining
- b) blockwork walls in garages
- c) skirtings.

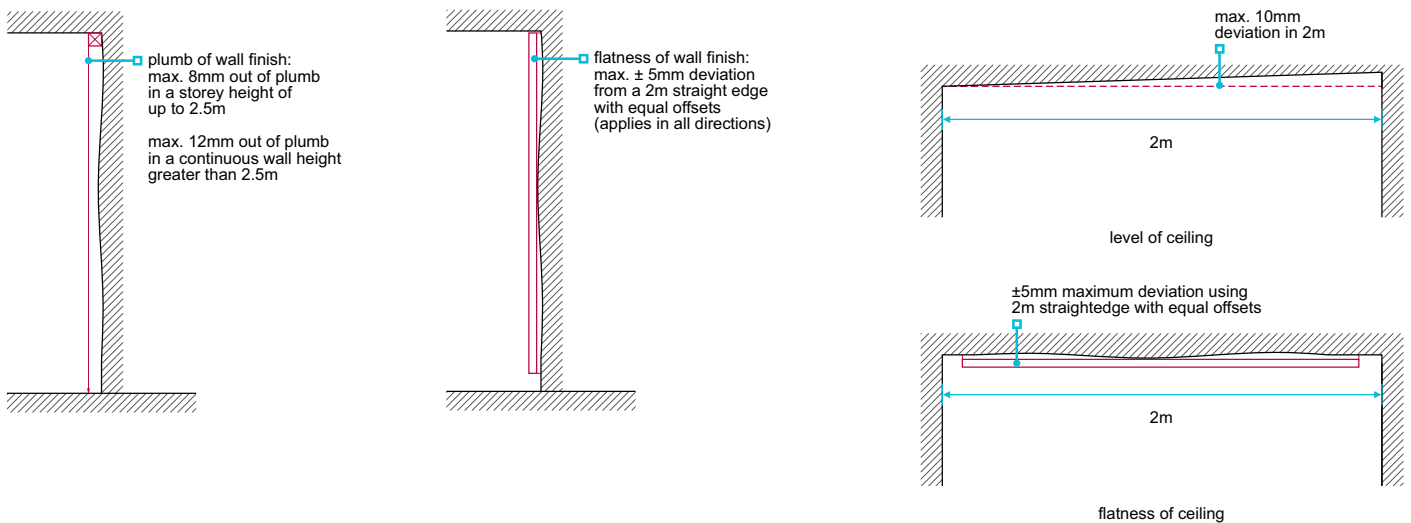
For walls and ceilings:

- surfaces should be reasonably uniform, although there may be minor textural differences around lights and other fittings
- there should be no visible gaps between fittings and the surface (e.g. around switch plates)
- jointing tape should be fully covered and unobtrusive in the finished surface.

### Plastering and dry lining

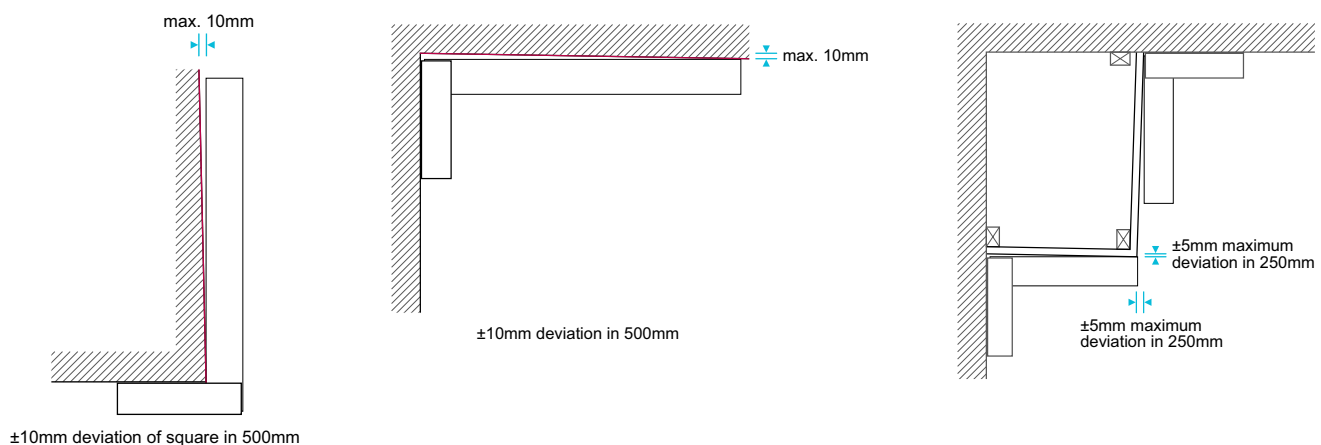
For plastered and dry lined surfaces:

- board joints should be within a maximum 3mm deviation, measured using a 450mm straight edge with equal offsets
- walls should be adequately flat and within a  $\pm 5\text{mm}$  deviation measured using a 2m straight edge with equal offsets
- the finish should be a maximum 8mm from plumb for walls up to 2.5m
- the finish should be a maximum 12mm of plumb for a continuous wall height over 2.5m.



Setting out of corners, duct casings, access covers and any associated framing should be:

- square
- neat and tidy
- provided with an appropriate decorative finish.



Also note:

- In plastered walls and ceilings, some tooling marks may be visible.
- Some cracking (up to 2mm wide) may occur at wall, floor and ceiling junctions, due to shrinkage and differential movement of materials.
- Small cracks may occur in wall finishes which pass across floors (e.g. in staircase walls).
- Where stair strings abut a wall, a crack of up to 4mm may appear as a result of shrinkage of materials.

### Blockwork walls in garages

Cracks, up to 2mm wide, in unplastered blockwork walls may be evident due to thermal movement and shrinkage.

### Skirtings

Where skirtings are installed:

- the gap between the floor finish (without coverings) and the bottom of the skirting should not exceed 5mm
- joints should present a continuous appearance when viewed from a distance of 2m in daylight (some initial shrinkage of the skirting may already be evident at completion of the property).

Also note:

- The gap between the floor finish and the skirting may increase due to normal drying out, shrinkage and/or deflection, particularly in timber floors.
- Gaps may appear at joints and corners due to shrinkage, and between the wall finish and skirting due to drying out, shrinkage and fixing position.

### Doors and windows <sup>9.1.4</sup>

**Doors and windows shall be installed to appropriate tolerances, including openings in walls, and external openings viewed from the inside.**

Openings in walls (including external openings viewed from the inside) should:

- be flat along the length of sills and window boards, with a maximum deviation of  $\pm 3\text{mm}$  in every 1m
- be level within 3mm across the sill measured from the frame (tiled sills may slope away from the window)
- have level heads and sills, a maximum of 5mm from level for openings up to 1.5m, and 8mm where larger
- have plumb reveals, a maximum of 5mm for openings up to 1.5m, and 8mm where larger
- be square within a  $\pm 5\text{mm}$  maximum deviation for reveals up to 250mm deep

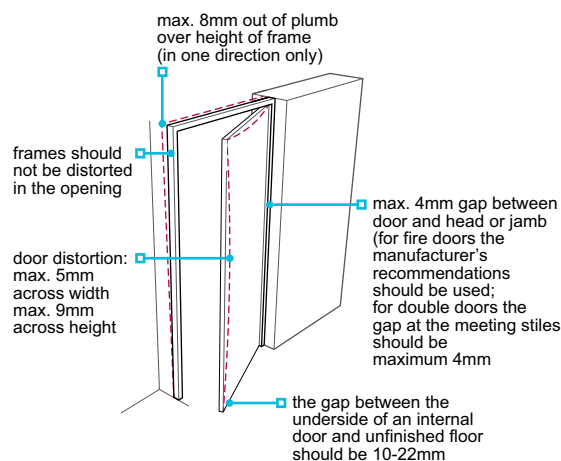
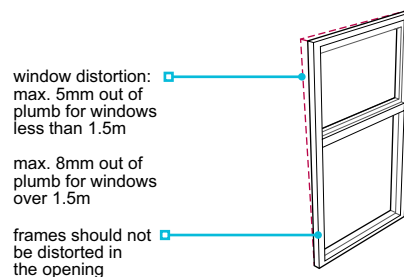
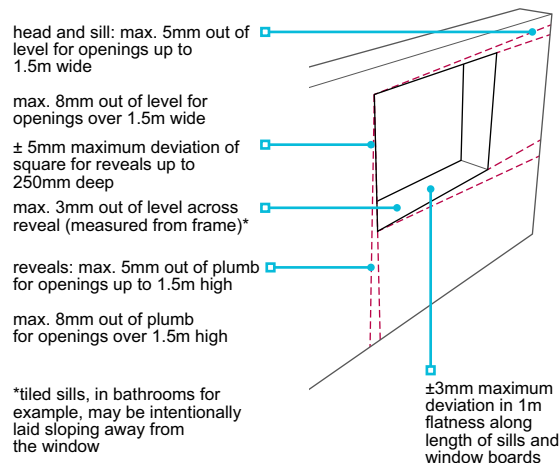
Window frames should not be distorted in the opening, and a maximum from plumb of:

- 5mm when up to 1.5m in height
- 8mm where larger.

Doors and frames should always be installed in accordance with the manufacturer's recommendations, not be distorted in the opening, and:

- frames should be within 8mm of plumb over the height of the frame and not out of plumb in two directions
- the gap between the door and head or jamb limited to a maximum of 4mm (for double doors, the gap at the meeting stiles should be within 4mm)
- distortion across doors limited to a maximum 9mm in the height, and 5mm in the width
- the gap between the underside of the door and unfinished floor limited to between 10-22mm (the covering should be selected accordingly, or the door height adjusted; in England and Wales, where a builder provides a floor finish, there should be a gap of 10mm between the bottom of 760mm wide doors and the floor finish).

The tolerances in this clause are without prejudice to satisfactory performance for weathertightness, exclusion of draught and fire resistance.



### Floors <sup>9.1.5</sup>

**Floors shall be built to appropriate tolerances.**

Floors should be:

- level within a 4mm deviation per 1m for floors up to 6m across
- a maximum of 25mm out of level for floors over 6m across
- flat within a  $\pm 5\text{mm}$  deviation, measured using a 2m straight edge with equal offsets.

Underfloor service ducts should be constructed so that the cover is level with the adjacent floor finish. The selection of floor finish should take into account that drying shrinkage of the floor may result in minor differences in level between the floor and duct cover, which may become evident with some types of thin floor coverings.

Also note:

- The effects of normal drying shrinkage on screeded floors may cause minor cracking.
- Timber floors and staircases naturally shrink as they dry. As this drying occurs, it may result in squeaking components as they move against each other. This is normal and to be expected.



**Glazing** <sup>9.1.6</sup>**Glass shall be free of undue defects.**

Glass should be checked in daylight, from within the room and from a minimum distance of 2m (3m for toughened, laminated or coated glass). The following are acceptable where they are not obtrusive or bunched:

- Bubbles or blisters.
- Hairlines or blobs.
- Fine scratches not more than 25mm long.
- Minute particles.

The above does not apply to areas within 6mm of the edge of the pane, where minor scratching may occur.

**Ceramic, concrete, terrazzo and similar tile finishes** <sup>9.1.7</sup>**Ceramic, concrete, terrazzo and similar tile finishes shall have an appropriate appearance.**

For ceramic, concrete, terrazzo and similar tile finishes:

- joints should be straight and in alignment, unless the tiles are, by design, irregular in shape
- wall tile joints should be a minimum of 1mm
- floor tile joints should be a minimum of 3mm, unless otherwise specified by the manufacturer
- joints in floor tiles should generally not exceed the tile thickness, although wider joints up to 10mm may be necessary to accommodate dimensional irregularities in some tiles
- should limit the effect of dimensional irregularities. Joints should be 'evened out' to maintain a regular appearance
- the variation in surface level should be within  $\pm 3$ mm measured using a 2m straight edge with equal offsets
- the variation between tiles and adjacent surfaces should be within 1mm deviation for joints less than 6mm wide and 2mm deviation for joints more than 6mm wide.

**Fitted furniture** <sup>9.1.8</sup>**Fitted furniture shall have an appropriate appearance.**

Fitted furniture, including doors and drawers, should:

- be visually aligned (vertically, horizontally and in plan), and there should not be significant differences in level at the intersection of adjacent worktops
- operate as intended by the manufacturer
- have uniform gaps between adjacent doors and/or drawers where appropriate
- not have conspicuous abrasions or scratches on factory-finished components when viewed in daylight from a distance of 0.5m.

Also note:

- No dimensional tolerance has been set for gaps between adjacent doors and/or drawers or for their alignment, because some variation will be necessary to take account of adjustments as part of the fitting process.
- No dimensional tolerance has been set for the abutment of adjacent worktops due to the variety of materials available and because minor variations, even with manufactured products, are inevitable and small differences in height may be unavoidable.
- Fitted furniture should be viewed from a distance of 2m.
- Conspicuous surface abrasions caused during installation should be removed in accordance with the manufacturer's recommendations which may include filling, polishing out, respraying or painting as appropriate.
- In rooms or areas where there is no daylight, scratches should be viewed in artificial light from fixed wall or ceiling outlets and not from portable equipment.

**Joint sealants** <sup>9.1.9</sup>**Joint sealants shall have a neat and tidy appearance.**

Sealants should be tooled to:

- remove blisters and irregularities
- achieve a compact, smooth neat surface finish.

Also note:

- Joints should be viewed from a distance of 2m, but may be less, depending on the location (e.g. showers and baths).

### Other surfaces and finishes <sup>9.1.10</sup>

#### Other surfaces and finishes shall have an appropriate appearance.

Other surfaces and finishes should:

- be reasonably smooth and free from nail holes, cracks and splits
- have joints filled
- be reasonably uniform in colour, texture and finish.

Where there are two or more adjacent socket, switch or service outlets, they should be aligned horizontally.

Where garage floors have not been sealed, dusting may occur.

Painted and varnished surfaces should be even in appearance and free from conspicuous runs and prominent brush marks.

Also note:

- Surfaces should be viewed in daylight from a distance of 2m and not by shining artificial light on the surface. Wall lights or uplighters should be switched off.
- Timber surfaces may show limited raised grain, and the colour and texture may also vary.
- Drying shrinkage of timber may cause cracking of the paint finish, particularly where joints occur in plaster and woodwork.
- Where painted surfaces are touched up, minor colour variations may occur.
- External finishes will dull over time, depending on a number of factors such as exposure to sunlight, rain and pollutants.
- Resin is likely to exude from knots, causing discoloration of paintwork, even though modern primers contain a compound to limit this.

### External works <sup>9.1.11</sup>

#### External works (including drives, paths, decks, terraces and balconies) shall have appropriate finishes.

Drives, paths, decks, terraces and balconies should be:

- within a maximum  $\pm 10$ mm deviation measured using a 2m straight edge with equal offsets; however, localised falls into gulleys and channels are acceptable
- designed and constructed to minimise the potential for standing water.

One hour after rain has stopped, areas of temporary standing water should not be deeper than 5mm or exceed 1m<sup>2</sup>.

Temporary standing water is not permitted adjacent to entrance doors.

Also note:

- Displacement and variations in surface levels, including scuffing and pitting, may arise due to settlement, natural ground movement and traffic.

Drainage covers should:

- align with the adjacent ground or surface finish (for channels, the cover should be set below the adjacent ground)
- the difference in height between a cover and the adjacent hard surfaces should allow for future settlement.

# Wall and ceiling finishes

## CHAPTER 9.2

This chapter gives guidance on meeting the Technical Requirements for internal wall and ceiling finishes.

9.2.1	Compliance	01
9.2.2	Provision of information	01
9.2.3	Plastering	01
9.2.4	Dry lining	02
9.2.5	Ceramic wall tiling	05



Raising Standards. Protecting Homeowners

**Compliance 9.2.1**

*Also see: Chapter 2.1*

**Wall and ceiling finishes shall comply with the Technical Requirements.**

Wall and ceiling finishes that comply with the guidance in this chapter will generally be acceptable.

**Provision of information 9.2.2**

**Designs and specifications shall be produced in a clearly understandable format, include all relevant information and be distributed to the appropriate personnel.**

Designs and specifications should be issued to site supervisors, relevant specialist subcontractors and suppliers, and include the following information:

- Schedule of finishes.
- Plaster thickness, mix and special requirements.
- Installation details of vapour checks behind dry lining.
- Fixing specification.
- Extent and detail of tiled surfaces.
- Location of services adjacent to tiled surfaces.

**Plastering 9.2.3**

*Also see: Chapter 8.1*

**Plastering shall provide an adequate substrate for the decorative finish.**

Materials for plastering should be in accordance with BS 8481 and those listed in Table 1.

Where plaster is intended to contribute to fire resistance or sound insulation, overall performance should be in accordance with the building regulations.

**Table 1:** Materials for use in plastering

<b>Plasters</b>	BS EN 13279	Gypsum binders and gypsum plasters.
	BS 5270-1	Specification for polyvinyl acetate (PVAC) emulsion bonding agents for indoor use with gypsum building plasters.
<b>Metal laths and beads</b>	BS 405	Specification for uncoated expanded metal carbon steel sheets for general purposes.
	BS EN 13658-1/2	Metal lath and beads. Definitions, requirements and test methods.

The background should be:

- given an appropriate treatment before plastering, in accordance with BS 8481
- suitably finished to provide an adequate key
- checked to ensure adequate and even suction
- sufficiently even to provide a reasonably flat plaster finish (excessive 'dubbing out' should be avoided).

Mixed background materials and associated differential movement can lead to cracks and should be avoided. Suitable precautions should be taken, e.g. using metal lathing.

Metal beads should be used to provide edge protection, and be fixed with zinc-plated fasteners, as recommended by the manufacturer.

**Table 2:** Recommended treatments for substrates

Surface	Treatment
High-density clay, or concrete bricks and blocks and dense concrete (including soffits)	Suitable bonding treatment, hacking, spatterdash, or stipple.
Mixed backgrounds, e.g. concrete with bricks/blocks	May require expanded metal to provide key for plastering and to reduce the effects of differential movement.
Lightweight concrete blocks	Plaster should not be stronger than recommended by the blockwork manufacturer.
Autoclaved aerated concrete blocks	Plastering should be conducted in accordance with the manufacturer's recommendations, accounting for the moisture content of the blocks.
Normal clay brickwork and concrete block	May require raked joints or the use of keyed bricks.
Plasterboard	Guidance is contained in BS 8212.

Where services are to be concealed by plaster, they should be:

- completed and tested before plastering
- protected against the adverse effects of chemical action or thermal movement.

To avoid surface cracking; metal lathing or wire netting should be used where there is an insufficient depth of plaster.

The plaster mix should be:

- as specified, or as recommended by the plaster manufacturer for the particular location and use
- checked to ensure undercoats and finishing coats are compatible
- appropriate for the strength and surface characteristics of the background
- applied by suitably trained operatives (specifically where plastic compound finishes are used)
- an appropriate quality for the intended finish
- of a type that does not include Portland cement and gypsum plaster in the same mix.

When plastering:

- completed work, especially timber, chipboard and glazing, should be protected from damp and damage
- avoid mixing excessive quantities of plaster (plaster should not be retempered)
- in cold weather, follow the guidance in chapter 3.2 'Cold weather working' (plasterwork damaged by frost should be removed and replaced)
- the background surface of each coat should be fully set (the surface should not be overworked, and adequate time should be left between coats to allow strength and suction to develop)
- dubbing out should be conducted well in advance of the application of the first coat
- the number of coats should be sufficient to achieve a reasonably plane finish
- surfaces should be dry, clean and free from laitance, grease, loose material or substances likely to prove harmful to the bond or the intended finished appearance of the plaster
- finished surfaces, reveals, soffits to openings, external angles, etc. should be in accordance with Chapter 9.1 'A consistent approach to finishes'
- ensure plaster is thoroughly mixed but avoid prolonged mixing
- the plaster should be applied to a thickness, excluding dubbing out, in accordance with Table 3.

**Table 3:** Plaster thickness

	Surface to be plastered	Minimum number of coats	Thickness of plaster
Walls	Metal lathing	3	13mm (nominal from lathing)
	Brickwork	2	13mm maximum
	Blockwork	2	13mm maximum
	Plasterboard or concrete	1	Sufficient to provide a crack-free surface
Ceilings	Concrete	2	10mm maximum
	Plasterboard	1	Skimcoat

### Dry lining <sup>9.2.4</sup>

**Dry lining shall provide an adequate substrate for the decorative finish. Issues to be taken into account include:**

- a) installation
- b) vapour control
- c) detailing and support
- d) fixing.

#### Installation

Dry lining should:

- not be started until the building is substantially weatherproofed
- provide performance in accordance with building regulations where it contributes to fire resistance
- be programmed so that finishes are applied as soon as possible after completion
- ensure that gap sealing is specified where necessary to prevent draughts.

**Table 4:** Standards relevant to dry lining

<b>BS 1230</b>	Gypsum plasterboard
<b>BS 8212</b>	Code of practice for dry lining and partitioning using gypsum plasterboard

### Vapour control

Vapour control layers should be used to reduce the risk of interstitial condensation, and be installed in accordance with:

- Chapter 6.2 'External timber framed walls'
- Chapter 7.1 'Flat roofs, porches and balconies'
- Chapter 7.2 'Pitched roofs'.

### Detailing and support

Support should be provided to plasterboard in accordance with Table 5.

**Table 5:** Frequency of support for plasterboard

Board thickness (mm)	Maximum timber support centres (mm)	Intermediate noggings required	Perimeter noggings required
9.5	400	No	Yes
	450	Yes	Yes
12.5	400	No	Yes
	450	No	Yes
	600	Yes	Yes
15	600	No	No

When fixing boards:

- damaged boards should not be used
- they should be fixed face side out, appropriate for plastering or directly applied finishes
- cut edges should finish over a support or nogging (though are permitted, where necessary, at perimeters)
- additional intermediate noggings may be required where fire resistance is necessary
- there should be adequate support for light points, socket outlets and other service installations
- openings for services and electrical outlets should be accurately cut (gaps in vapour control layers should be taped and sealed)
- ceiling boards should be staggered to minimise any risk of cracking.

Joints between boards should be neatly formed, flush, and suitably finished:

- with scrim tape or paper tape, where boards are to be plastered
- with tape, and filled, where boards are not to be plastered (tapered edge boards should be used for directly applied finishes), or
- as recommended by the manufacturer.

Where double layers of plasterboard are used, they should:

- be positioned so joints are staggered between layers
- have the first layer fully fixed and have all cut edges supported
- have the second layer supported on all edges with noggings provided to suit.

Dry lining should be:

- completely taped and filled at board joints and at the abutments to ceilings and internal walls
- finished to an appropriate standard and in accordance with Chapter 9.1 'A consistent approach to finishes'.

### Fixing

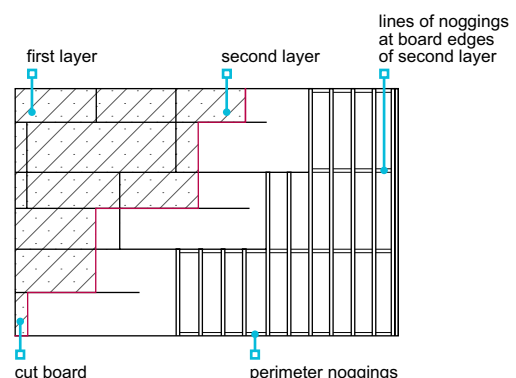
Plasterboard should be fixed to:

- timber using plasterboard nails or dry wall screws
- metal using dry wall screws, or
- masonry using adhesive dabs.

Where insulated dry lining is used, nailable plugs should be specified in accordance with the manufacturer's recommendations, and at a minimum of two per board.

Nails or screws should not project above the board surface and should be:

- 10mm minimum from paper-bound edges
- 13mm minimum from cut ends of boards
- 6mm minimum from edges of timber members.



**Table 6:** Acceptable fixing centres and fixings

Fixing	Location and spacing	Coating
Nail	Walls and ceilings: approximately 150mm centres (eight per linear metre)	Hot dip galvanised, zinc electroplated or sheradised steel
Screw	Ceilings: approximately 230mm centres (eight per two linear metres) Walls: approximately 300mm centres (five per linear metre)	Zinc electroplated or black phosphate (or to the board manufacturer's recommendations)

**Table 7:** Acceptable fixing lengths

Board thickness (mm)	Nail length (mm)	Screw length (mm) into timber	Screw length (mm) into steel
9.5	30	32	22
12.5	40	36	22
15	40	36	25

Where dry lining is fixed with adhesive dabs, it should be:

- securely fixed and filled at external and internal corners, including door and window openings
- filled with jointing compound where required, at gaps around service points, electric sockets, light switches, etc.
- installed with a continuous ribbon of adhesive to the perimeter of external walls, and around openings and services, to prevent air infiltration.

Adhesive dabs should be at 300mm centres measured vertically, and in accordance with Table 8.

**Table 8:** Dabs according to board dimensions

Thickness of wall board (mm)	Width of wall board (mm)	Dabs per board (rows)
9.5	900	3
9.5	1200	4
12.5	1200	3

Dry lining to receive ceramic wall tiling should be supported in accordance with Table 9 or the guidance given in BS 8212.

**Table 9:** Board fixing guidance for walls to receive ceramic tiles

Description	Board thickness (mm)	Support centres (mm)	Additional support	Maximum height (mm)	Comments
Timber frame (including stud walling)	12.5, 15	400-450 600	No Timber noggings 600mm centres (measured vertically)	3 600 3 600	
Timber battens	12.5, 15	400	Battens at head, base and intermediate positions not exceeding 1200mm centres	3 600	
Direct bond	9.5	450 dabs of adhesive in rows	Horizontal dabs at mid-storey height	3 600	Complete at least 10 days before tiling
Independent steel stud lining, 48mm or 60mm	2 x 12.5	400	Mid-point support	3 000	
48mm metal stud partitions	15 2 x 12.5 each side, or 2 x 15 each side	400 400		2 700 3 600	
70mm metal stud partitions	15 2 x 12.5 each side, or 2 x 15 each side	400 400		3 600 3 600	
146mm metal stud partitions	2 x 15 each side	600	Additional stud at 300mm up to tile height	3 600	

### Ceramic wall tiling <sup>9.2.5</sup>

**Ceramic wall tiling shall provide a surface adequate for its location and intended use (including appearance and durability).**

Where a fixed shower or showerhead fixing is provided over a bath, at a height that will permit persons to stand under it:

- a screen or other suitable means of containing the water should be provided
- surfaces which will become regally wetted should be tiled or have an appropriate alternative water-resistant finish.

Backing surfaces for tiling should:

- be in accordance with Table 9 and BS 8212
- be strong enough to support the weight of the adhesive and tiling (where separate coats are used, they should be well bonded)
- provide an adequate mechanical key
- be sufficiently even to achieve an even and plane tiled surface
- provide adequate and reasonably consistent suction
- avoid differential movement; where this may occur, precautions should be taken, e.g. metal lathing or wire netting fixed across junctions
- be moisture resistant, where frequent wetting occurs
- be dry, clean and free from laitance, grease, loose material or any substance likely to affect the bond or finish
- be reasonably even (i.e. not have gaps greater than 3mm for thin bed adhesives or 6mm for thick bed adhesives, when using a 2m straight edge).

Where the backing surface contains soluble salts, and where cement mortar is used as an adhesive, precautions should be taken, such as the use of mortar with sulfate-resisting cement.

Gypsum plasters should not be used where:

- repeated or persistent heating occurs, e.g. on flues or near heat sources
- repeated or persistent wetting may occur.

Backgrounds may be improved by:

- raking out masonry joints
- hacking and scratching
- applying a bonding agent (particularly on very smooth and dense surfaces).

Tiles should be appropriate for their location and intended use. When specifying tiles, consideration should be given to:

- surface finish
- size and thickness
- colour
- edge shape
- fittings (coves, skirtings, etc.)
- accessories (soap tray, paper holder, hooks, etc.).

Tiles should be:

- fixed in accordance with manufacturers' instructions
- suitable for the location, intended use and background; their weight on lightweight plaster should not exceed 20kg/m<sup>2</sup>
- fixed according to the background, using cement mortar or proprietary adhesive
- solidly bedded in water-resistant adhesive on a moisture-resistant background, where frequent wetting occurs.

**Table 10:** Standards for tiling

<b>BS EN 14411</b>	Ceramic tiles. Definitions, classification, characteristics and marking.
<b>BS EN 12004</b>	Adhesives for tiles. Definitions and specifications.
<b>BS EN 13888</b>	Grouts for tiles. Definitions and specifications.

When tiling:

- courses should be straight and even to form a plane and regular surface, especially around fittings and fixtures
- there should be no cut or unfinished tiles at exposed edges or external corners
- joints should be even and cut neatly
- spacing should be sufficient to allow for expansion
- up to sanitary fittings and fixings, the sealing method should be in accordance with the design and account for movement
- proprietary water-resistant grouting should be used in accordance with the manufacturers' recommendations.

Appropriately designed movement joints should be:

- built into tiling at centres at a maximum of 4.5m, vertically and horizontally
- provided at vertical corners in large tiled areas
- located at junctions where there are variations in surfaces or backgrounds
- 1-2mm where tiles are without spacer lugs.

Grouting should be:

- as specified in the design, including mix and colour
- cement-based epoxy resin or a proprietary product
- waterproof in and around shower enclosures and where tiling can be saturated.



# Floor finishes

## CHAPTER 9.3

This chapter gives guidance on meeting the Technical Requirements for floor finishes, including:

- integral insulation
- screeds
- ceramic, concrete and similar tiles
- flexible sheet and tiles
- woodblock
- asphalt.

9.3.1	Compliance	01
9.3.2	Provision of information	01
9.3.3	Insulation	01
9.3.4	Screed	01
9.3.5	Ceramic, concrete, terrazzo and similar tile finishes	03
9.3.6	Wood finishes	04
9.3.7	Flexible sheet and tile finishes	05
9.3.8	Asphalt finishes	06
9.3.9	Staircase finishes	06



Raising Standards. Protecting Homeowners

### Compliance <sup>9.3.1</sup>

*Also see: Chapters 2.1, 5.1, 5.2, 6.4 and 8.1*

#### Floor finishes shall comply with the Technical Requirements.

Floor finishes which comply with the guidance in this chapter will generally be acceptable (structural floors should be in accordance with the relevant Standards chapter).

### Provision of information <sup>9.3.2</sup>

#### Designs and specifications shall be produced in a clearly understandable format, include all relevant information and be distributed to the appropriate personnel.

Designs and specifications should be issued to site supervisors, relevant specialist subcontractors and suppliers, and include the following information:

- Schedule of finishes.
- Screed thickness and mix.
- Details of sound insulating floors.
- Extent and detail of tiled surfaces.
- Location of services adjacent to tiled surfaces.
- Details of staircase finishes.

### Insulation <sup>9.3.3</sup>

#### Thermal and acoustic insulation shall provide appropriate performance, and be suitable for the intended location and use.

Materials and constructions which are in accordance with building regulations are generally acceptable.

Suitable sound insulation materials include:

- flexible material
- mineral fibre quilt insulation
- board material for use under screeds (e.g. impact sound duty (ISD) grade pre compressed expanded polystyrene)
- proprietary products which have been assessed in accordance with Technical Requirement R3.

**Table 1:** Thermal insulation materials

Material	Standard	Grade or description
EPS (expanded polystyrene)	BS EN 13163	70
PUR (rigid polyurethane)	BS 4841	For use under screeds
PIR (rigid polyisocyanurate)		
Fibre building board	BS 1142 Part 3	Insulating board (softboard)
Proprietary material	Technical Requirement R3	

### Screed <sup>9.3.4</sup>

*Also see: Chapters 3.2 and 8.1*

#### Non-structural floor screeds shall be adequate for the location and intended use, and provide a suitable background for floor finishes. Issues to be taken into account include:

- a) installation
- b) screed thickness
- c) screed over insulation.

#### Installation

Before screeding, background surfaces should be:

- clean and free of debris (e.g. dust and gypsum removed); concrete should be wetted and brushed
- suitably prepared to provide an adequate mechanical key, where bonded screeds are required, cement grouting or a bonding agent should be specified to provide adequate adhesion.

Damp proofing should be completed before screeding starts.

Screeding should not take place in weather conditions which could adversely affect the finished construction, and:

- should be scheduled to allow suitable drying time before following trades
- in hot or dry weather, precautions should be taken to prevent the screed surface drying out too quickly
- in cold weather, screeds should not be installed (screed damaged by cold should be removed and replaced).

Non-structural screed should be:

- installed to the specified thickness and provide an even surface, suitable for the intended finish in accordance with the relevant British Standards and the floor finish manufacturer's recommendations
- of a suitable sand cement mix (generally between 1:3 and 1:4½ cement:sand). Where deeper than 40mm, concrete may be used
- (where the floor is to include a monolithic slab) installed within three hours of the concrete sub-floor being poured.
- mixed using only proprietary additives that have been assessed in accordance with Technical Requirement R3
- thoroughly compacted, where required by the design, using either a heavy tamper, mechanical compactor or vibrator.

Proprietary non-structural screeds should be installed in accordance with the manufacturer's recommendations.

Surface sealers or hardeners should only be used in accordance with the manufacturer's instructions.

Where services are bedded in the screed:

- there should be a minimum 25mm of cover over the highest point of pipes and insulation
- provision should be made for the thermal movement of water pipes
- pipes should be protected against chemical attack (e.g. by using purpose-made sleeves or ducts).

Non-structural screed over underfloor heating should:

- be sub-divided into bays not exceeding 40m<sup>2</sup>, with a maximum length of 8m, or installed per room
- have expansion joints which are consistent with those in the slab.

Where concrete floor slabs are to serve directly as a wearing surface without an additional topping, they should be in accordance with BS 8204-2 and power floated.

Completed floor finishes should be protected against damage from traffic.

Standards relevant to screeding include:

<b>BS 8204</b>	'Screeds, bases and in-situ floorings. Code of practice'.
<b>BS 8201</b>	'Code of practice for installation of flooring of wood and wood-based panels'.
<b>BS 8203</b>	'Code of practice for installation of resilient floor coverings'.

### Non-structural screed thickness

Thickness of cement and sand screeds should be in accordance with with Table 2.

**Table 2:** Thickness of non-structural screed

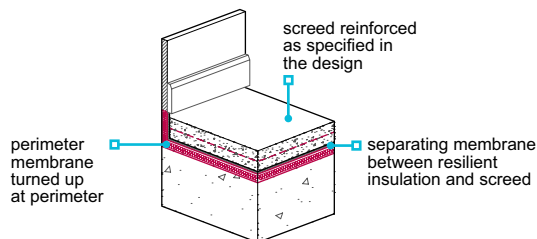
Method of laying	Minimum thickness at any point (mm)
Installed monolithically with base	12
Installed on, and bonded to, a set and hardened base	20
Installed on a separating membrane (e.g. 1000g polyethylene)	50
Installed on resilient slabs or quilts (screed reinforced with wire mesh)	65
Above services, reinforcement or insulation to services	25

For concrete ground-bearing floors, a maximum 20mm monolithic screed may be acceptable as part of the required thickness.

### Screed over insulation

Where screed is to be installed over insulation, the screed should be reinforced, and the insulation should:

- provide adequate compressive strength to support wet construction screeds and floor loads
- be tightly butted and, where required, turned up at perimeters to prevent cold bridging
- be separated from the screed by a membrane (the membrane should be compatible with the insulation, and have joints lapped and taped, and be turned up at the perimeter).



Sound insulating floating floors should be in accordance with building regulations.

### Ceramic, concrete, terrazzo and similar tile finishes <sup>9.3.5</sup>

#### Tile flooring shall provide a suitable wearing surface for the location and intended use.

Before tiling is started:

- ensure that the substrate is sufficiently dry (generally, six weeks for concrete bases and three weeks for screed is adequate)
- ensure the substrate is reasonably true and level ( $\pm 3\text{mm}$  using a 3m straight edge), and installed to falls where required
- differences in level should be dubbed out
- the surface should be clean and free from laitance, dirt, dust, grease and materials incompatible with the adhesive.

When installing tiles to floors:

- they should be bedded on a solid bed of mortar or proprietary adhesive, of a thickness appropriate for the material
- the manufacturer's recommendations should be followed where proprietary adhesives are used
- they should be arranged to minimise cutting and to provide joints which are straight, neat, and of even width
- accessories, such as covings and skirtings, should match the tile pattern, and be fixed so that joints are aligned with those in the floor
- they should be installed with minimum 3mm joints, unless otherwise specified by the manufacturer.

Where tiles are to be fixed to a wood-based substrate:

- the floor should be designed to take the additional loads of tiles, and any other materials (e.g. overlays)
- they should be suitable for laying over a timber base
- they should be bedded with deformable (flexible) tile adhesive, e.g. C2S1, and grouted in accordance with the manufacturer's recommendations

Timber floor decking should be:

- plywood for use in exterior conditions (minimum 15mm for joists at 400/450mm centres and minimum 18mm for joists at 600mm centres) screwed to the joists at 300mm centres with all square edges supported on joists or noggings (plywood should be installed with a 1.5-2mm movement gap between boards and at abutments, and be acclimatised to the room conditions and sealed on the underside and square edges, before laying, with a suitable sealer such as polyurethane varnish) or
- chipboard floor decking overlaid with minimum 10mm plywood suitable for exterior conditions, acclimatised, sealed and fixed as previously indicated, or proprietary separating/decoupling layers, tile backer boards or tile bedding reinforcement sheets used in accordance with the manufacturer's recommendations.

Movement joints should be:

- provided around the floor perimeter and at rigid upstands, where tiled areas are wider than 2m
- used to separate bays at 8-10m centres
- a minimum of 3mm wide unless otherwise specified by the manufacturer.

Grout should be:

- cement-based epoxy resin or a proprietary product
- water resistant, where tiles may become saturated.

Standards relevant to floor finishes include:

<b>BS 8204-3</b>	'Screeds, bases and in-situ floorings. Polymer modified cementitious levelling screeds and wearing screeds. Code of practice'.
<b>BS EN 13748-1</b>	'Terrazzo tiles for internal use'.
<b>BS EN 14411</b>	'Ceramic tiles. Definitions, classification, characteristics, evaluation of conformity and marking'.
<b>BS 5385</b>	'Wall and floor tiling'.

**Wood finishes** <sup>9.3.6</sup>

Also see: BS 5250 and BRE Report 'Thermal insulation: avoiding risks'

**Wood and wood-based flooring shall provide a suitable wearing surface for the location and intended use.**

**Issues to be taken into account include:**

- a) thermal insulation and DPMs
- b) sound insulation
- c) condition of the substrate
- d) directly applied finishes
- e) indirectly applied finishes.

Wood and wood-based flooring should be installed ensuring that:

- services beneath the floor finish are tested before the floor is installed
- underfloor heating is kept on, before and during the floor laying
- wood finishes are conditioned to the appropriate moisture content
- where required, DPMs are incorporated, in accordance with manufacturer's recommendations and the design.

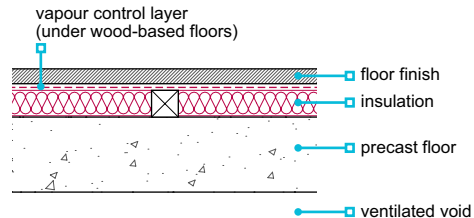
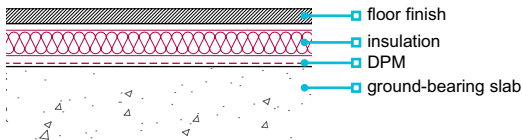
Standards relevant to wood floor finishes include:

<b>BS 8201</b>	'Code of practice for installation of flooring of wood and wood-based panels'.
<b>BS 1187</b>	'Specification for wood blocks for floors'.
<b>BS 4050</b>	'Specification for mosaic parquet panels'.
<b>BS 1202</b>	'Specification for nails'.
<b>BS 1297</b>	'Specification for tongued and grooved'.

**Thermal insulation and DPMs**

Methods of providing insulation include:

- insulation positioned above in-situ concrete slab (DPM required)
- insulation positioned above dry, precast system (DPM not required).



Proprietary insulated flooring should be in accordance with:

- Technical Requirement R3
- manufacturer's recommendations on vapour control layers and DPMs.

**Sound insulation**

Floating floor finishes should be designed and constructed to:

- isolate the floor finish from the supporting floor and walls
- avoid excessive movement or squeaking
- avoid the use of fixings which penetrate the insulation layer
- ensure there are no airpaths, especially at the perimeter.

Where flooring is to be installed on a resilient material on a separating floor, edges should be isolated from walls and skirtings by a resilient layer.

Where a floor relies on a soft floor covering to provide the minimum standard of sound insulation, the covering should be fixed permanently in position.

**Condition of the substrate**

Screeds or concrete to receive wood flooring should be dry. The floor should:

- be tested and the moisture content suitable, in accordance with BS 8201
- be allowed to cure for a sufficient period of time (generally two months for 50mm screed, and six months for concrete slabs), or
- have a DPM or vapour control layer incorporated in the floor construction to protect the wood finishes (moisture should not be trapped between the layers).

Screeds or concrete to receive wood flooring should:

- be free from high spots, nibs and major irregularities
- have differences in level dubbed out.

### Directly applied finishes (wood blocks, parquet, wood mosaic, etc.)

Directly applied finishes should be installed:

- in accordance with the manufacturer's recommendations
- using evenly spread adhesives
- using the correct adhesives, e.g. bitumen rubber emulsion in accordance with BS 8201 or proprietary adhesives assessed in accordance with Technical Requirement R3
- according to the specified pattern, and leaving gaps around the perimeter for movement.

Screeds or concrete surfaces should be treated with a suitable primer in accordance with the adhesive manufacturer's recommendations.

### Indirectly applied finishes (softwood boarding, wood-based panel products)

Indirectly applied finishes should be installed with:

- vapour control layers where required
- battens fixed to prevent excessive movement
- preservative treated battens, in accordance with Chapter 3.3 'Timber preservation (natural solid timber)'
- battens spaced in accordance with Table 3.
- provision made to support heavy items, such as storage heaters and boilers

**Table 3:** Spacing of battens for indirectly applied floor finishes

	Thickness of finish (mm)	Maximum batten centres (mm)
Chipboard (type P5)	18/19	450
	22	600
Plywood	15	450
	18	600
Oriented strand board (type OSB3)	15	450
	18/19	600
Other types of floor	In accordance with the manufacturer's instructions.	

Chipboard and oriented strand board should be fixed to battens:

- with flathead ring shank nails or screws
- at 200mm-300mm centres at perimeters
- with fixings 2.5 x the thickness of the board
- at 400mm centres on intermediate supports.

Plywood should be fixed to battens:

- with 10 gauge nails or screws
- at 150mm centres at perimeters
- a minimum of 10mm from the edges of boards
- at 300mm centres on intermediate supports.

### Flexible sheet and tile finishes <sup>9.3.7</sup>

*Also see: BS 5250 and BRE Report 'Thermal insulation: avoiding risks'*

**Flexible sheet and tile finishes shall provide a suitable wearing surface for the location and intended use.**

Flexible sheet and tile finishes should be:

- installed in accordance with the manufacturer's recommendations, and generally be fully bonded
- reasonably level and smooth, particularly at doorways and junctions
- installed on a backing surface which is even and without high spots or cracks; where necessary, using a levelling underlay of a type and thickness recommended by the flooring manufacturer or in accordance with Table 4
- fitted with skirtings, coves, coverstrips and other preformed components, where required, and in accordance with the manufacturer's recommendations.

**Table 4:** Acceptable types of underlay for boarded surfaces

Type of underlay	Minimum thickness (mm)
Hardboard	3.2
Plywood	4
Chipboard	9
Oriented strand board	6

Chipboard and oriented strand board underlay should be fixed to battens:

- with flathead ring shank nails or screws
- with fixings 2.5 x the thickness of the board
- at 200mm-300mm centres (9mm from edges)
- across the boards, at 400mm centres.

Plywood or hardboard underlay should be fixed:

- with ring shank nails or staples
- with nails/screws at least 10mm from the edge of the panel
- around perimeters, at 100mm centres (12mm from edges)
- across the sheets, at 150mm centres.

Flexible sheet flooring materials should:

- be stored in a clean and ventilated place
- not be stored in cold conditions, unless permitted by the manufacturer
- not be exposed to temperatures less than 18°C for a period of 24 hours before, or during, laying.

The substrate should be sufficiently dry to prevent adverse effects on the flooring, and where:

- there is a risk of trapping moisture or interstitial condensation, permeable finishes should be used
- flexible sheet or tile flooring is installed on ground bearing concrete floors, a DPM should be incorporated to prevent rising moisture adversely affecting floor finishes.

When installing flexible sheet or tile flooring:

- ensure underfloor services are not damaged
- it should be cut so that it fits neatly around fittings, pipes, etc.
- adhesives should be spread evenly and left for the correct period of time to ensure full bonding
- the surface should be pressed down firmly, loaded or rolled as necessary to prevent curling, lifting or bubbling
- surplus adhesive should be removed
- welded joints should be provided in accordance with the manufacturer's recommendations
- adjustment after initial contraction or expansion should be made where necessary.

Standards relevant to flexible sheet and tile finishes include:

<b>BS EN ISO 10581</b>	'Resilient floor coverings. Homogeneous poly(vinyl chloride) floor covering'
<b>BS EN ISO 10595</b>	'Resilient floor coverings. Semi-flexible/vinylcomposition (VCT) poly(vinyl chloride) floor tiles'
<b>BS EN 650</b>	'Resilient floor coverings. Polyvinyl chloride floor coverings on jute backing or on polyester felt backing or on a polyester felt with a polyvinyl chloride backing'
<b>BS EN 651</b>	'Resilient floor coverings. Polyvinyl chloride floor coverings with foam layer'
<b>BS EN 12104</b>	'Resilient floor coverings. Cork floor tiles'
<b>BS 8203</b>	'Code of practice for installation of resilient floor coverings'.

### Asphalt finishes <sup>9.3.8</sup>

**Asphalt finishes shall be suitable for the location and intended use.**

Asphalt should be:

- in accordance with BS 6925 (limestone aggregate)
- Grade I or II and 15-20mm thick (which applies to the floor finishes and underlay)
- applied as one coat when used as underlay for other finishes
- in accordance with the floor manufacturer's recommendations when used with a suspended floor system.

### Staircase finishes <sup>9.3.9</sup>

*Also see: Chapter 6.6*

**Staircase finishes shall permit safe usage and be suitable for their intended use.**

The rise and going should remain uniform after application of the staircase finish, including at the top and bottom of the flight.

For communal stairs (e.g. in escape routes in blocks of flats), non-slip nosings or inserts should be:

- provided where specified
- fixed in accordance with the manufacturer's recommendations.

# Finishings and fitments

## CHAPTER 9.4

This chapter gives guidance on meeting the Technical Requirements for finishings and fitments (including cupboards and internal trim).

9.4.1	Compliance	01
9.4.2	Provision of information	01
9.4.3	General provisions – cupboards and fitments	01
9.4.4	Finishings and internal trim	01
9.4.5	Joinery	02
9.4.6	Airing cupboards, cupboards, worktops and fitments	02
9.4.7	Ironmongery, prefabricated items and other materials	02
9.4.8	Protection and handover	03



Raising Standards. Protecting Homeowners



### Compliance <sup>9.4.1</sup>

*Also see: Chapter 2.1*

#### **Finishings and fitments shall comply with the Technical Requirements.**

Finishings and fitments which comply with the guidance in this chapter will generally be acceptable.

### Provision of information <sup>9.4.2</sup>

#### **Designs and specifications shall be produced in a clearly understandable format, include all relevant information and be distributed to the appropriate personnel.**

Designs and specifications should be issued to site supervisors, relevant specialist subcontractors and suppliers.

### General provisions – cupboards and fitments <sup>9.4.3</sup>

#### **The builder shall provide fixed and built-in fitments in accordance with the specification.**

In kitchens, the specification should allow for:

- preparation and cooking of food
- washing up, drying and storage of dishes and utensils
- storage of dry foods
- storage of perishable foods
- laundering
- storage of domestic cleaning appliances (part of which should be suitable for brooms, upright cleaners and similar equipment)
- 1m circulation space in front of all work surfaces, cupboards and appliances.

A depth of 600mm can be assumed for appliances (where intended but not provided).

Space or facilities for laundering and cleaning items may be provided outside the kitchen area.

Space should be provided for general storage, clothes, linen and bedding. Airing cupboards are required in homes which do not have central or whole home heating.

Shelving supports should be fixed securely and so that shelves are level.

### Finishings and internal trim <sup>9.4.4</sup>

*Also see: Chapter 6.8*

#### **Finishings and internal trim shall be suitable for their location and intended use, securely fixed, and finished to established standards of workmanship.**

When fixing trim and components:

- they should be in accordance with the specification
- fireplace surrounds, panelling and features should be complete and suitably joined to the adjacent surfaces
- nails should be punched below the surface of timber, and holes filled
- damage should be avoided (where damage does occur, it should be made good).

Trim and finishings should be:

- sufficiently wide to mask joints around built in fitments, etc. allowing for movement and shrinkage
- fixed in accordance with building regulations (e.g. with minimum separation distances where near heat sources)
- selected and installed to give a neat appearance
- installed in accordance with the manufacturer's recommendations.

Architraves should be:

- parallel to frames and linings
- accurately mitred, or scribed, to fit tightly and neatly
- fixed with an equal margin to each frame member
- securely fixed to prevent curling.

Skirting should:

- be mitred and scribed at external and internal angles, as appropriate
- tightly abut architraves
- run level and scribed to floors.

Proprietary trim, skirting and architraves should be fixed in accordance with the manufacturer's recommendations.

**Joinery** <sup>9.4.5</sup>

**Wood and wood-based materials shall be of the quality and dimensions required by the design.**

Joinery and the materials used should be installed to established standards of workmanship, and have no visible defects after the finish has been applied. Issues that should be taken into account include:

- fit and construction of joints (including finger joints)
- construction of moving parts
- gluing and laminating
- surface finishes.

Relevant standards include:

<b>BS EN 942</b>	'Timber in joinery. General requirements'
<b>BS EN 312</b>	'Particleboards'
<b>BS 1186</b>	'Timber for and workmanship in joinery'.

**Airing cupboards, cupboards, worktops and fitments** <sup>9.4.6</sup>

**Airing cupboards, cupboards, worktops and fitments shall be installed to provide satisfactory appearance and performance. The builder shall provide fixed and built-in fitments in accordance with the design.**

Cupboards, worktops and fitments should be:

- checked to ensure they are undamaged before they are installed
- installed as shown in the design (worktops spanning between units may require additional support)
- plumb, level and scribed to wall faces, where necessary.

Cupboards should be installed ensuring that:

- doors operate freely and fit openings closely and evenly
- drawers run smoothly, and locks and catches properly engage.

Cupboards (including wall-hung units) should be securely fixed, using:

- fixings of an appropriate size, and in accordance with the manufacturer's instructions (generally, plugs and screws to masonry and screws to timber)
- the predrilled holes in units and brackets provided by the manufacturer.

Where worktops or unit panels are cut, edges should be sealed using a metal or plastic strip glued to the edge with waterproof adhesive. Alternatively, an appropriate waterproof joint may be used. Sinks and hob units which are inset in worktops, and vanity units, should be sealed with a waterproof joint.

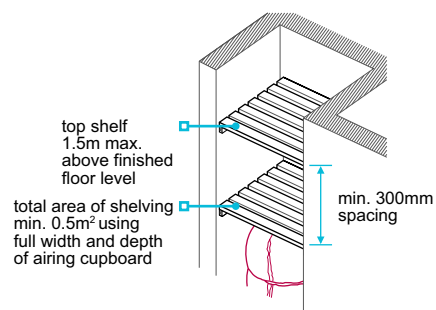
Where appropriate, gaps between fitments and wall tiling should be sealed with a waterproof joint and brought to a smooth finish.

Wardrobes should be fitted with hanging rails, and intermediate supports used where necessary to avoid bending.

Internal doors (including airing cupboard doors) should be fitted in accordance with Chapter 6.7 'Doors, windows and glazing'.

Airing cupboards should:

- be separated from other storage
- have a minimum 0.5m<sup>2</sup> of easily reached shelving suitable for the airing of clothes
- have a 300mm minimum spacing between shelves
- have a suitable heat source, such as a hot water cylinder
- not have shelving higher than 1.5m.



**Ironmongery, prefabricated items and other materials** <sup>9.4.7</sup>

**Ironmongery, prefabricated items and other similar materials shall be suitable for the intended use.**

Relevant standards include:

- BS EN 1935 'Building hardware. Single-axis hinges. Requirements and test methods'.

### Protection and handover <sup>9.4.8</sup>

**Finishings and fitments shall be suitably protected during construction, and be undamaged at handover.**

Appropriate protection should be provided to finishings and fitments (including to doors, trim, balustrades, fireplace surrounds, panelling and other special features) to ensure they are not damaged. Kitchens, including cupboards, doors, fittings and worktops, should be suitably protected.

Prior to completion and handover:

- work should be left in a clean state
- decorating should be completed in accordance with chapter 9.5 'Painting and decorating'
- temporary coverings and protection should be removed, and the fitments and finishings cleaned and dusted.

# Painting and decorating

## CHAPTER 9.5

This chapter provides guidance on meeting the Technical Requirements for painting and decorating.

9.5.1	Compliance	01
9.5.2	Provision of information	01
9.5.3	Storage	01
9.5.4	Conditions for painting and decorating	01
9.5.5	Timber	01
9.5.6	Steel	02
9.5.7	Walls	02
9.5.8	Wallpapering	03
9.5.9	Other surfaces	03
9.5.10	Completed painting and decorating	03



Raising Standards. Protecting Homeowners

### Compliance <sup>9.5.1</sup>

*Also see: Chapter 2.1*

#### **Painting and decorating shall comply with the Technical Requirements.**

Painting and decorating that complies with the guidance in this chapter will generally be acceptable.

Paint finishes should be selected and applied in accordance with BS 6150 'Painting of buildings. Code of practice'.

Chapter 9.1 'A consistent approach to finishes' provides further guidance on the quality of painting and decorating finishes.

### Provision of information <sup>9.5.2</sup>

#### **Designs and specifications shall be produced in a clearly understandable format, include all relevant information and be distributed to the appropriate personnel.**

Designs and specifications should be issued to site supervisors, relevant specialist subcontractors and suppliers, and include:

- specification of preparatory work
- details of specialist finishes.
- schedule of finishes

### Storage <sup>9.5.3</sup>

#### **Materials for painting and decorating shall be adequately protected from the cold.**

Painting and decorating materials should:

- be protected against frost before use
- not be used where they have been damaged by frost.

### Conditions for painting and decorating <sup>9.5.4</sup>

#### **Painting and decorating shall take account of the climatic and building conditions to ensure a suitable finish.**

The painting and decoration of external surfaces should not be undertaken where:

- weather conditions may adversely affect the completed work
- surfaces are moist
- frost occurs, or is due to occur, before the paint has been applied or has dried
- rain is expected before the paint dries.

When decorating internal walls:

- cold surfaces may cause problems with water-borne paints, even though the air temperature may be above freezing
- surfaces should be free from condensation before applying paint and coatings; they should not be applied until the moisture has evaporated from the surface.
- paintwork should not be adversely effected by dust

### Timber <sup>9.5.5</sup>

#### **The painting and decorating of timber and timber-based materials shall be compatible with the species of timber, provide adequate protection and be suitable for the intended use and location. Prefabricated components and joinery shall be finished to a suitable quality, and protected.**

When painting or decorating timber, the moisture content should be a maximum of 18%.

Paint and paint systems should be used in accordance with the manufacturer's recommendations, and be compatible with the surface to be decorated.

Preparation should ensure:

- door and window furniture is removed
- sharp arrises are rubbed down (to enable an even coating)
- unsound wood, loose or highly resinous knots, etc. are cut out, replaced and made good
- surfaces are free from dirt, dust and moisture
- raised grains, tool and machine marks are removed
- where there is deterioration of the primer or seal coat, surfaces are rubbed down and a second coat applied
- surfaces are refinished with fillers and glasspaper as appropriate
- where joinery is delivered preprimed, priming meets the requirements in this chapter
- nail holes, splits and other imperfections are stopped
- where joinery is prefabricated, the first coat of paint or stain is applied before fixing.

Knotting should:

- comply with BS 1336 'Specification for Knotting' (this may not be effective against heavy exudation of resin)
- be applied using a brush, or as part of the priming process for joinery.

One full round coat of primer should be applied to all surfaces to be painted, including:

- hidden surfaces of external woodwork
- cut ends of external woodwork
- rebates for glazing and backs of glazing beads.

Relevant standards for primer include:

- BS 4756 'Specification for ready-mixed aluminium priming paints for woodwork'
- BS 5082 'Specification for water-borne priming paints for woodwork'
- BS 5358 'Specification for solvent-borne priming paints for woodwork'.

Paint or stain should be applied to external timber to provide protection and stability, even where the timber has been preservative treated (unless the preservative treatment manufacturer confirms otherwise). Primer, paint and stain finishes should be compatible with preservative treatment.

Undercoat and gloss should be applied ensuring that it provides a satisfactory finish, and:

- it is not thinned (unless recommended by the manufacturer)
- each application is a full round coat and surfaces are lightly rubbed down with glasspaper between coats
- a minimum of one priming coat, one undercoat and one finishing coat are used (unless an alternative recommendation is made by the manufacturer)
- each coat is applied within one month of the previous.

Stain and varnishes should be:

- applied as recommended by the manufacturer to provide appropriate cover
- applied to surfaces which have been suitably prepared to provide adequate adhesion and an acceptable appearance
- applied when the substrate is dry
- suitable for the species of timber.

Varnish should be applied with a minimum of three coats on interior surfaces. On exterior surfaces, varnish should be suitable for the conditions (yacht or high gloss) and applied with a minimum of four coats. Surfaces should be sanded between coats.

Stain should:

- be a two-coat system or be in accordance with the manufacturer's recommendations
- not be applied to door or window rebates which are to be glazed with linseed-oil putty.

BS 6952 provides guidance on exterior wood coating systems.

Prefabricated joinery and components should be:

- protected from damage
- supplied with, or given, a coat of primer before fixing
- stored under cover and primed, where supplied untreated, as soon as possible after delivery
- reprimed where primer is damaged.

### Steel <sup>9.5.6</sup>

**Steelwork shall be coated to provide adequate protection and be suitable for the intended use and location.**

Decorative finishes may be applied to galvanised steel following suitable preparation with a mordant wash.

Decorative finishes applied to steelwork that has been protected by coatings (including intumescent paint for fire resistance) in accordance with Chapter 6.5 'Steelwork', must be compatible with the protective coating. The manufacturer's recommendations should be followed. Any damage to the protective coatings should be made good prior to decorative finishes being applied.

### Walls <sup>9.5.7</sup>

**Walls shall be finished to provide an even and consistent appearance, to established levels of workmanship.**

**Issues to be taken into account include:**

- a) external masonry and rendering
- b) plaster and plasterboard surfaces.

#### External masonry and rendering

Paint or decorative finishes to external masonry and rendering should:

- be appropriate for the substrate, and be in accordance with the manufacturer's recommendations
- be applied to surfaces which are clean, free from dust and loose deposits
- not be applied to external brickwork or render where they could trap moisture in the construction and cause frost damage, sulfate attack or other detrimental effects.

Where bricks have no upper limit on their soluble salt content, the brick manufacturer's written agreement to the application of a finish should be obtained.

Where the decorative system is part of the weather resistance of the rendering, it should be assessed in accordance with Technical Requirement R3.

Where surfaces have varying suction, they should be stabilised with a treatment recommended by the manufacturer.

### Plaster and plasterboard surfaces

A sealing coat should be applied to dry lining, and surfaces prepared for decoration, in accordance with the manufacturer's recommendations.

Plaster and plasterboard surfaces should be prepared in accordance with the manufacturer's recommendations and the design.

Where plaster and skim coat is applied to plasterboard:

- surfaces should be visibly sound, without signs of powdering or crumbling
- joints should be completed and cracks, nail holes and surface imperfections filled
- the surface should be rubbed down with glasspaper and dusted, where necessary
- surfaces should be stabilised, either with a coat of thinned paint or with a sealant as recommended by the manufacturer
- a minimum of two coats of paint should be applied.

Where building boards are used, coatings should be in accordance with the board manufacturer's recommendations.

### Wallpapering <sup>9.5.8</sup>

**Wallpapering shall be finished to provide an even and consistent appearance, to established levels of workmanship.**

Where wallpaper or coverings are used:

- surfaces should be dry, even and smooth before wallpaper is applied
- surfaces should be sized or sealed as necessary
- adhesives should be in accordance with the wallpaper manufacturer's recommendations
- they should be properly aligned and neatly fixed
- electrical switch plates should be temporarily removed and the papering accurately trimmed so that it will tuck behind the fitting upon completion.

### Other surfaces <sup>9.5.9</sup>

**Surfaces shall be finished to provide an even and consistent appearance, to established levels of workmanship.**

For glazing rebates in windows and doors treated with stains:

- linseed-oil putty should not be specified
- appropriate sealants should be used in accordance with the manufacturer's recommendations.

The insides of metal gutters (other than aluminium) should be painted with a suitable protective paint.

Non-ferrous pipework (e.g. copper pipes) should be painted with the normal decorative finishes.

### Completed painting and decorating <sup>9.5.10</sup>

**Completed paintwork shall be to established levels of workmanship and suitably protected.**

Painting and decorating should be complete, and:

- surfaces that are not intended to be painted should be free of paintmarks
- evenly applied, free from conspicuous runs or prominent brush marks, and the background or undercoat should not be visible
- where ironmongery has been removed, it should be correctly replaced
- removed and reapplied where spilt, splashed or badly applied
- protected against dirt and damage until handover.

# Garages

## CHAPTER 10.1

This chapter gives guidance on meeting the Technical Requirements for integral, attached and detached garages.

10.1.1	Compliance	01
10.1.2	Provision of information	01
10.1.3	Garage foundations	01
10.1.4	Garage floors	02
10.1.5	Garage walls	03
10.1.6	Resistance to fire spread	03
10.1.7	Security	04
10.1.8	Doors and windows	04
10.1.9	Garage roofs	04
10.1.10	Permanent prefabricated garages and carports	05
10.1.11	Services	05



Raising Standards. Protecting Homeowners



### Compliance <sup>10.1.1</sup>

Also see: Chapter 2.1

#### Garages shall comply with the Technical Requirements.

Garages which comply with the guidance in this chapter will generally be acceptable.

### Provision of information <sup>10.1.2</sup>

#### Designs and specifications shall be produced in a clearly understandable format, include all relevant information and be distributed to the appropriate personnel.

Designs and specifications should be issued to site supervisors, relevant specialist subcontractors and suppliers, and include the following information:

- Location of garages.
- Relevant levels, in relation to an agreed reference point.
- Details of foundations.
- Waterproofing arrangements.
- Construction details of the roof structure and coverings.
- Construction details for walls.
- External and internal finishes.
- Services, where applicable.

### Garage foundations <sup>10.1.3</sup>

#### Garage foundations shall transmit all loads to the ground safely and without undue movement. Issues to be taken into account include:

- |   |                            |
|---|----------------------------|
| a) hazardous ground   | d) adjacent structures     |
| b) type of foundation required for integral/attached garages              | e) underground services    |
| c) type of foundation required for detached garages and blocks of garages | f) provision for movement. |

Garage foundations should adequately support the imposed loads, taking account of ground conditions.

Further guidance is given in Chapter 4.3 'Strip and trench fill foundations'.

#### Hazardous ground

For foundations on hazardous ground, the following chapters are relevant:

- 4.1 'Land quality – managing ground conditions'.
- 4.2 'Building near trees'.
- 4.4 'Raft, pile, pier and beam foundations'.

Any existing fill on the site of the garage should be examined and identified. Where any potential health hazard or risk of damage is indicated, appropriate precautions should be taken, as described in the following chapters:

- 4.1 'Land quality – managing ground conditions'.
- 5.1 'Substructure and ground-bearing floors'.

#### Type of foundation required for integral/attached garages

Foundations for integral or attached garages should be the same as those for the home, unless proper consideration is given to each foundation, and the possibility of differential movement between them.

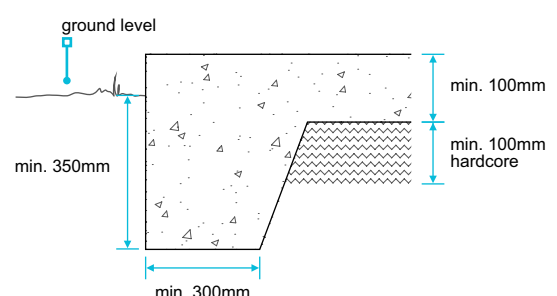
#### Type of foundation required for detached garages and blocks of garages

Foundations for detached individual garages or blocks of garages should avoid damage caused by differential loads and uneven settlement.

Where the ground is uniform and provides a satisfactory foundation bearing, an unreinforced edge thickened concrete slab may be used.

Unreinforced concrete slabs should:

- have a minimum thickness of 100mm
- have a minimum downstand thickening of 350mm below ground level around the whole perimeter of the slab
- have a minimum width of edge thickening of 300mm
- be constructed on 100mm minimum of properly compacted hardcore
- have dimensions not exceeding 6m in any direction – for dimensions greater than this, movement joints should be provided.



### Adjacent structures

Foundations for garages should not impair the stability of the home or any other adjacent structure.

### Underground services

Garage foundations that are to be above or near services should be constructed so that no excessive settlement of foundations or damage to services occurs (see Chapter 5.3 'Drainage below ground').

### Provision for movement

Movement joints in foundations should be provided:

- between homes and attached garages where there is a change of foundation type or depth
- at 6m intervals where unreinforced concrete slab foundations are used.

## Garage floors <sup>10.1.4</sup>

**Garage floors shall transmit all loads to either the foundations or the ground safely and without undue movement. Issues to be taken into account include:**

- a) bearing capacity of the ground
- b) resistance of the floor to moisture from the ground
- c) thickness of floor slabs
- d) floor drainage
- e) structural topping.

Garage floors will be acceptable where they are in accordance with:

- Chapter 5.1 'Substructure and ground-bearing floors'
- Chapter 5.2 'Suspended ground floors'
- the guidance given in this chapter.

Unless ventilation is specifically required, the void beneath a garage floor which is suspended precast concrete may be unventilated where:

- the floor has adequate durability
- the ground beneath is well drained
- there is unlikely to be a build-up of soil gases.

### Bearing capacity of the ground

Where the depth of fill exceeds 600mm, concrete floors should be in accordance with Chapter 5.2 'Suspended ground floors' and BS 8103-4.

Supporting fill should comply with the requirements in Chapter 5.1 'Substructure and ground-bearing floors'.

Where protection is needed to prevent attack by sulfates in either the ground, ground water or fill below the slab, an impervious isolating membrane should be provided between the concrete and the ground.

### Resistance of the floor to moisture from the ground

Generally, a DPM is unnecessary, except where:

- it is needed to prevent dampness entering the home, or
- the floor has to be protected against chemical attack from the ground.

Where no DPM is provided, the floor may show signs of dampness.

Where the floor is below ground level, precautions should be taken to prevent the entry of ground water, and tanking may be required.

### Thickness of floor slabs

Ground-bearing floors, where provided, should not be less than 100mm thick, including a float finish.

### Floor drainage

When practicable, garage floors should be laid to falls to ensure that water or spillage is directed out of the garage via the vehicle doorway.

### Structural topping

Where reinforced screeds are to be incorporated as structural topping, they should be designed by an engineer in accordance with Technical Requirement R5.

### Garage walls <sup>10.1.5</sup>

**Walls for garages shall transmit all loads to foundations safely and without undue movement. Issues to be taken into account include:**

- |  |  |
|--|--|
| a) stability of walls above ground     | c) provision for movement                        |
| b) stability of walls retaining ground | d) adequate resistance to rain and ground water. |

Garage walls will be acceptable where they are in accordance with:

- Chapter 5.1 'Substructure and ground-bearing floors'
- Chapter 6.1 'External masonry walls'
- the guidance given below.

#### Stability of walls above ground

Walls for detached garages and external walls for attached garages should:

- be not less than 90mm thick
- have adequate lateral restraint against wind loading
- in the case of walls up to 200mm thick, have piers at the corners (unless buttressed by a return) and at intermediate centres not exceeding 3m.

#### Stability of walls retaining ground

Garage walls retaining ground should be:

- suitable for the ground conditions
- structurally adequate.

Where garage walls act as retaining walls, they should be designed in accordance with Chapter 5.1 'Substructure and ground-bearing floors' or by an engineer in accordance with Technical Requirement R5.

#### Provision for movement

Movement joints in garage walls, as described in BS EN 1996-2, should be provided:

- between homes and attached garages
- where there are movement joints in foundations.

#### Adequate resistance to rain and ground water

To protect the wall from rising ground moisture, a DPC should be provided at a level at least 150mm above the level of adjacent ground.

Garage walls constructed from a single leaf of masonry, such as brickwork or blockwork approximately 100mm thick, will not be impervious to wind-driven rain and consequently could become damp.

In areas of severe exposure, single leaf walls may require a high standard of workmanship and possibly surface treatment to prevent an unacceptable level of rain penetration.

Where a garage is integral or attached, the design should ensure that dampness cannot enter the home.

Where a wall is below ground level, precautions should be taken to prevent the entry of ground water by:

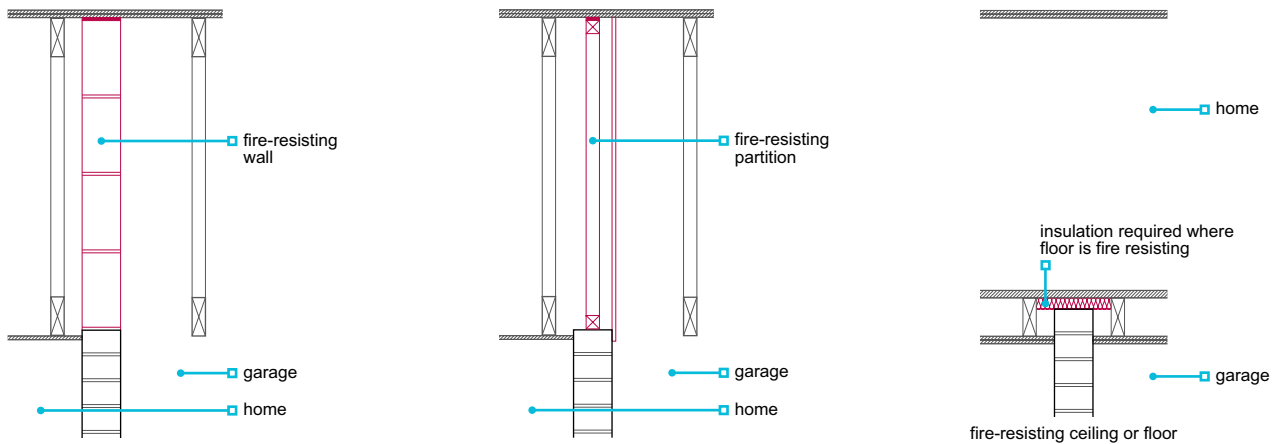
- tanking (see Chapter 5.4 'Waterproofing of basements and other below ground structures')
- the use of DPCs and DPMs
- drainage of ground behind the wall.

### Resistance to fire spread <sup>10.1.6</sup>

**Garages shall be constructed so as to prevent fire spread to the home from the garage.**

Fire resistance between homes and integral or attached garages, may be provided by:

- a wall in brickwork, blockwork or fire-resisting studwork up to the underside of the roof covering
- a half-hour fire-resisting floor or ceiling
- constructions where nominal half-hour fire resistance can be proven.



### Security <sup>10.1.7</sup>

**Garages shall be constructed to provide reasonable security against unauthorised entry, in particular where garages are linked.**

Where garages of different ownership are linked, walls should prevent direct access from one garage to another.

### Doors and windows <sup>10.1.8</sup>

**Garage doors and windows shall be adequate for their purpose. Issues to be taken into account include:**

- a) robustness
- b) ease of operation.

Doors and windows will be acceptable where they are in accordance with Chapter 6.7 'Doors, windows and glazing'.

#### Robustness

Frames should be selected and fixed having taken into account the type and weight of the garage door.

#### Ease of operation

Proprietary doors and door gear should be installed in accordance with the manufacturer's recommendations.

Care should be taken to ensure that garage doors are in proper working order at handover.

### Garage roofs <sup>10.1.9</sup>

**Garage roofs shall satisfactorily resist the passage of rain and snow to the inside of the building, support applied loads and self-weight, and transmit the loads to the walls safely and without undue movement.**

**Issues to be taken into account include:**

- a) holding down
- b) bracing
- c) detailing at abutments
- d) movement
- e) adequate disposal of rainwater.

Garage roofs will be acceptable where they are in accordance with:

- Chapter 7.1 'Flat roofs, porches and balconies', or
- Chapter 7.2 'Pitched roofs'.

#### Holding down

To prevent uplift, flat roofs and, where necessary, pitched roofs should be provided with holding-down straps at not more than 2m centres where the roof members bear on the supporting wall. Straps should have a minimum cross-section of 30mm x 2.5mm, be at least 1m long and have three fixings to the wall.

#### Bracing

The building designer should specify all bracing. Trussed rafter roofs should be braced in accordance with Chapter 7.2 'Pitched roofs', unless the roof is designed and braced in accordance with PD 6693-1.

All timber bracing to trussed rafters should be at least 100mm x 25mm in section and nailed twice to each trussed rafter. Nailing should be 3.35mm (10 gauge) x 65mm long galvanized round wire nails.

### Detailing at abutments

Precautions should be taken at abutments between a garage roof and the main building or between stepped garages, including:

- flashings and weatherproofing that allow for differential movement
- cover flashings formed from metal or other approved material
- cavity trays that divert water from inside the cavity to the external surface of the roof.

### Movement

Movement joints in foundations and the structure should be continued through roof coverings and be provided with appropriate weather protection.

### Adequate disposal of rainwater

The provision of rainwater should be in accordance with building regulations.

Individual roofs, or combinations of roofs that drain from one to another, with a total area greater than 6m<sup>2</sup>, should have a rainwater drainage system.

Where rainwater from a large roof surface discharges onto a garage roof, precautions should be taken to prevent premature erosion of the lower surface.

Rainwater should not discharge from the roof directly to a drive or path.

For details on the design of rainwater disposal systems, reference should be made to the following chapters, as appropriate:

- 7.1 'Flat roofs, porches and balconies'
- 7.2 'Pitched roofs'.

## Permanent prefabricated garages and carports <sup>10.1.10</sup>

**Permanent prefabricated garages and carports shall be suitable for their intended purpose.**

Permanent prefabricated garages and carports should:

- have appropriate foundations
- be structurally adequate
- provide appropriate weathertightness
- provide adequate separation between linked garages of different ownership.

Prefabricated garages should be erected in accordance with the manufacturer's recommendations.

Particular care should be taken to ensure adequate holding down of carports and other light structures against wind action.

## Services <sup>10.1.11</sup>

**The provision of any service or appliance within a garage shall be in accordance with relevant regulations.**

**Issues to be taken into account include:**

- a) protection of water services against frost
- b) provision of electricity
- c) risk of fire or explosion.

Where services or appliances are provided in garages, they should comply with the guidance below and with the following chapters, as appropriate:

- 5.3 'Drainage below ground'
- 8.1 'Internal services'.

### Protection of water services against frost

A rising main should not be located within a garage.

A water supply or outlet in a garage should have adequate provision for isolating and draining down.

Pipes should be insulated and located so as to minimise the risk of freezing.

### Provision of electricity

The provision of electric lighting and socket outlets in a garage is at the discretion of the builder.

All electrical installations should comply with BS 7671 'Requirements for Electrical Installations. IET Wiring Regulations'.

### Risk of fire or explosion

Installation in a garage of an oil or gas burning boiler or heating appliance should be in accordance with any relevant statutory regulations.

# Drives, paths and landscaping

## CHAPTER 10.2

This chapter provides guidance on meeting the Technical Requirements for drives, paths and landscaping, including:

- private roads
- shared private drives
- private drives
- car parking areas.

10.2.1	Compliance	01
10.2.2	Provision of information	01
10.2.3	Stability	01
10.2.4	Freestanding walls and retaining structures	01
10.2.5	Guarding and steps	01
10.2.6	Drives, paths and landscaping	02
10.2.7	Materials	06
10.2.8	Garden areas	07
10.2.9	Waterlogging	07
10.2.10	Timber decking	07
10.2.11	Landscaping	07



Raising Standards. Protecting Homeowners

### Compliance <sup>10.2.1</sup>

*Also see: Chapter 2.1*

#### Drives, paths and landscaping shall comply with the Technical Requirements.

Drives, paths and landscaping that comply with the guidance in this chapter will generally be acceptable.

In this chapter 'home' includes a house, bungalow, flat or maisonette. The 'garden area' is the land within the curtilage up to 20m from the habitable parts of the home (i.e. not garages/outbuildings). This distance is measured from the external walls.

All works should be completed in accordance with:

- the design, and
- the ground remediation statement (where applicable).

Formation levels should be set out in accordance with the design.

### Provision of information <sup>10.2.2</sup>

#### Designs and specifications shall be produced in a clearly understandable format, include all relevant information and be distributed to the appropriate personnel.

All works relating to drives, paths and landscaping should be fully specified.

Designs and specifications should be issued to site supervisors, relevant specialist subcontractors and suppliers.

### Stability <sup>10.2.3</sup>

#### Precautions shall be taken to ensure stability of the ground.

Where the ground may become surcharged during construction, precautions should be taken to ensure stability.

Gabion and timber structures should not be used to provide support to homes, garages, roads, drives, car parking areas or drainage systems.

Retaining structures that give support to the foundations of a home should be completed before work starts on the construction of the foundations of the home.

### Freestanding walls and retaining structures <sup>10.2.4</sup>

#### Freestanding walls and retaining structures shall be adequate for their intended purpose.

Freestanding walls should be in accordance with:

- BS EN 1996-1 'Design of masonry structures'
- BRE Good Building Guide 14.

Retaining structures should be in accordance with:

<b>BS EN 1992</b>	'Design of concrete structures'.
<b>BS EN 1996</b>	'Design of masonry structures'.
<b>BS EN 1997-2</b>	'Geotechnical design. Ground investigation and testing'.
<b>BRE Good Building Guide 27</b>	'Building brickwork and blockwork retaining walls'.

All retaining structures, more than 600mm high, should be designed by an engineer in accordance with Technical Requirement R5.

Where timber structures more than 600mm high are used for retaining ground in boundary situations, they should be designed with a desired service life of 60 years.

Where planters are provided, they should be designed to support the volume of retained soil and the plant species.

### Guarding and steps <sup>10.2.5</sup>

#### Retaining structures and steps shall be adequately guarded and allow safe use.

Guarding should be provided where:

- structures are retaining land more than 600mm high to which people have access
- a retaining structure is more than 600mm high and the dimension from the top of the retaining wall to the higher ground level is less than 300mm, or
- a path is adjacent to a vertical difference in level of more than 600mm (including where ground adjacent to the path falls away at an angle of more than 30° from the horizontal).

The guarding should:

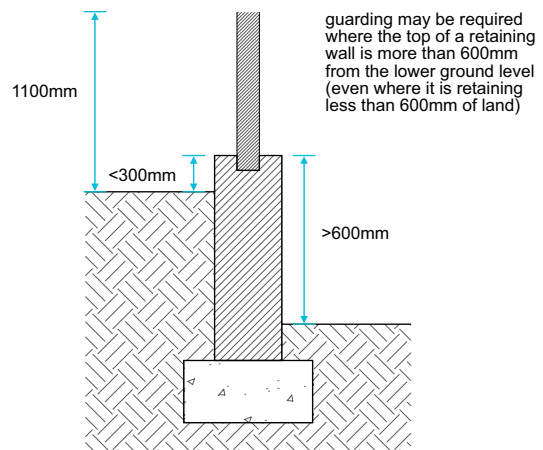
- be a minimum of 1100mm high
- not be readily climbable by children
- not allow a 100mm diameter sphere to pass through.

External steps that are not considered under building regulations should:

- have a maximum rise of 220mm
- have a minimum going of 220mm
- be reasonably uniform.

A handrail should be provided where the total rise of a flight of external steps is more than 600mm and the going of individual steps is less than 600mm.

Guidance for the provision of handrails to steps that form an accessible approach can be found in supporting documents to building regulations.



## Drives, paths and landscaping <sup>10.2.6</sup>

**Appropriate access (including private roads, shared private drives, private drives, car parking and paths) shall be provided to and around the home. Issues to be taken into account include:**

- a) general construction considerations
- b) drainage
- c) construction details
- d) minimum sub-base thickness
- e) house paths and patios.

Homes should be provided with suitable access through the provision of private roads, shared private drives, private drives, car parking areas and paths, as appropriate.

### General construction considerations

Private roads, shared private drives, private drives, car parking areas and paths should comply with relevant building regulations. Where abutting the home, they should be at least 150mm below the DPC, and laid to fall away from the home (unless a channel or other suitable means of collection and disposal is provided).

All vegetable matter should be removed from the area of the proposed works.

Only suitable fill material comprising clean, well-consolidated crushed rock, hardcore, slag or concrete should be used to make up levels.

Sub-bases should be mechanically consolidated in layers not exceeding 225mm.

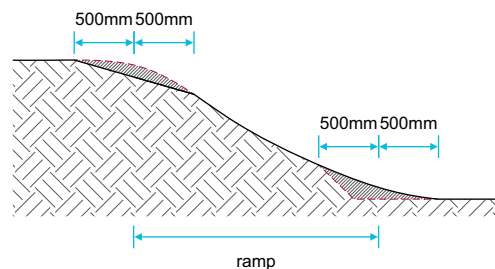
Finished ground levels should be compatible with:

- DPC levels
- cover levels of drainage access points

Private roads, shared private drives and private drives should:

- be appropriate for the loads
- provide reasonable access to and from a garage or car parking area
- have a maximum gradient of 1:6
- where the gradient is more than 1:10 and the gradient changes, have suitable transition lengths to reduce the risk of vehicles grounding.

- depth of underground services (gas, electricity, water and drains)
- adjacent surfaces.





Underground drainage or services that are below a private road, shared private drive, private drive, car parking area, path or patio should be protected against damage, as described in Chapter 5.3 'Drainage below ground'.

Edge restraint or kerbing should have a profile and foundation, which is suitable to form a permanent supporting edge for the expected vehicle loads on the road or drive.

Pedestrian access should be provided within the curtilage of each home to the main entrance and the secondary entrance where present:

- Where entry to the home can be gained directly from a garage, a path to a secondary access door is not required.
- Where the secondary entrance is to a mid-terrace home or ground floor flat, a path to a secondary access door is not required.
- Where a garage, carport or car parking area is provided within the curtilage, a path should be provided to it from the home.

Where appropriate, a drive can be regarded as a path for the provision of access.

Paths should have a maximum slope of 1:6. On steeper sloping ground, steps may be required.

**Table 1:** Suitable path widths

Location and use	Minimum width (mm)
Within curtilage to main entrance, or any entrance designated by Building Regulations.	900
Paths used for the removal of refuse to the collection point.	900
Paths adjoining a home.	700
Paths 100mm or more from the wall of a home.	600
All other cases.	600

### Drainage

Private roads, shared private drives and private drives should have adequate rainwater drainage and disposal.

Paved areas should:

- have vertical alignment, finished levels, transition arrangements and gradients in accordance with the design
- have surfaces with adequate falls, cross-falls and drainage to ensure that surface water is suitably drained
- have sub-base levels with the same longitudinal gradient and cross-fall as the finished level
- have surfaces not flatter than 1:40 or have a camber of 1:40 where no fall is available to avoid 'flat spots'
- have surfaces with a minimum finished fall of 1:80 where they form private drives and paths
- drain away from the home (and garage), or drain to a channel or other suitable means of collection and disposal adjacent to the home
- not drain surface water from private areas onto adopted areas
- not be within 2m of a soakaway.

Where paving slabs are laid abutting drainage channels and gully grates, etc., the upper surface of the paving slab should be set approximately 5mm above the grating.

Where it is intended to use porous or permeable surfaces as part, or all, of the rainwater drainage system, reference should be made to CIRIA report C522 – Sustainable urban drainage systems design manual for England and Wales.

**Construction details**

The construction of private roads, shared private drives, private drives and car parking areas should be constructed in accordance with the tables below, or an equivalent alternative.

**Table 2a:** Private road having frequent use by commercial vehicles

Construction <sup>(1)</sup>		Road type		
		Road (bituminous macadam)	Road (block pavers)	Footpath (bituminous macadam)
Sub-base	Granular sub-base material type 1 to clause 803 table 8/2 MCHW Volume 1 Series 800 <sup>(2)</sup>	Table 3	Where California Bearing Ratio (CBR) is 5% or less = 150 <sup>(3)</sup> Where CBR is greater than 5% = Table 3	225 <sup>(3)</sup>
Base (road base)	Dense bituminous macadam (100/150 pen paving grade bitumen) with crushed rock aggregate to BS 4987 (group 1 mix)	100 (0/32mm size to clause 5.2)	N/A	N/A
	Concrete designation (BS 8500-2 table 7)	N/A	N/A	N/A
Binder course (base course)	Dense bituminous macadam (100/150 pen paving grade bitumen) with crushed rock aggregate to BS 4987 (group 2 mix)	60 (0/20mm size to clause 6.5)	60 (0/20mm size to clause 6.5)	60 (0/20mm size to clause 6.5)
Surface course (wearing course)	Dense bituminous macadam (100/150 pen paving grade bitumen) with crushed rock aggregate to BS 4987 (group 3 mix)	30 (0/10mm size to clause 7.4)	N/A	20 (0/6mm size to clause 7.5)
	Hot rolled asphalt to BS 594-1	40 (designation 30% 0/14)	N/A	N/A
	Mastic asphalt to BS 1447	30 (grade S – 40% 0/10mm size)	N/A	N/A
	Concrete designation (BS 8500-2 table 7)	N/A	N/A	N/A
Bedding course	Sharp sand to BS 7533-3 category II of annex D	N/A	50	N/A
Pavers	Block pavers to BS 6717 of class markings W2, A2 and S3 (weathering, abrasion and slip/skid classes) <sup>(6)</sup>	N/A	80	N/A

**Table 2b:** Shared parking and associated access areas having frequent use by commercial vehicles

Construction <sup>(1)</sup>		Road type	
		Bituminous macadam	Block pavers
Sub-base	Granular sub-base material type 1 to clause 803 table 8/2 MCHW Volume 1 Series 800 <sup>(2)</sup>	Table 3	Table 3
Base (road base)	Dense bituminous macadam (100/150 pen paving grade bitumen) with crushed rock aggregate to BS 4987 (group 1 mix)	80 (0/32mm size to clause 5.2)	N/A
	Concrete designation (BS 8500-2 table 7)	100 grade GEN2 <sup>(4)</sup>	N/A
Binder course (base course)	Dense bituminous macadam (100/150 pen paving grade bitumen) with crushed rock aggregate to BS 4987 (group 3 mix)	60 (0/20mm size to clause 6.5)	N/A
Surface course (wearing course)	Dense bituminous macadam (100/150 pen paving grade bitumen) with crushed rock aggregate to BS 4987 (group 2 mix)	30 (0/10mm size to clause 7.4)	N/A
	Hot rolled asphalt to BS 594-1	N/A	N/A
	Mastic asphalt to BS 1447	N/A	N/A
	Concrete designation (BS 8500-2 table 7)	N/A	N/A
Bedding course	Sharp sand to BS 7533-3 category II of annex D	N/A	50
Pavers	Block pavers to BS 6717 of class markings W2, A2 and S3 (weathering, abrasion and slip/skid classes) <sup>(6)</sup>	N/A	80

**Table 2c:** Shared drives having infrequent use by commercial vehicles

Construction <sup>(1)</sup>		Road type			
		Bituminous macadam	Concrete	Block pavers	Gravel
Sub-base	Granular sub-base material type 1 to clause 803 table 8/2 MCHW Volume 1 Series 800 <sup>(2)</sup>	Table 3	Table 3	Table 3	Table 3
Base (road base)	Dense bituminous macadam (100/150 pen paving grade bitumen) with crushed rock aggregate to BS 4987 (group 1 mix)	<sup>(5)</sup>	N/A	N/A	N/A
	Concrete designation (BS 8500-2 table 7)	N/A	N/A	N/A	N/A
Binder course (base course)	Dense bituminous macadam (100/150 pen paving grade bitumen) with crushed rock aggregate to BS 4987 (group 2 mix)	80 (0/32mm size to clause 6.4) or (0/20mm size to clause 6.5)	N/A	N/A	N/A
Surface course (wearing course)	Dense bituminous macadam (100/150 pen paving grade bitumen) with crushed rock aggregate to BS 4987 (group 3 mix)	30 (0/10mm size to clause 7.4)	N/A	N/A	<sup>(7)</sup>
	Hot rolled asphalt to BS 594-1	40 (designation 30% 0/14)	N/A	N/A	N/A
	Mastic asphalt to BS 1447	30 (grade S – 40% 0/10mm size)	N/A	N/A	N/A
	Concrete designation (BS 8500-2 table 7)	N/A	150 grade PAV2	N/A	N/A
Bedding course	Sharp sand to BS 7533-3 category II of annex D	N/A	N/A	50	N/A
Pavers	Block pavers to BS 6717 of class markings W2, A2 and S3 (weathering, abrasion and slip/skid classes) <sup>(6)</sup>	N/A	N/A	80	N/A

**Table 2d:** Private drives and parking areas having use by cars and light vehicles

Construction <sup>(1)</sup>		Road type			
		Bituminous macadam	Concrete	Block pavers	Gravel
Sub-base	Granular sub-base material type 1 to clause 803 table 8/2 MCHW Volume 1 Series 800 <sup>(2)</sup>	Table 3	Table 3	Table 3	Table 3
Base (road base)	Dense bituminous macadam (100/150 pen paving grade bitumen) with crushed rock aggregate to BS 4987 (group 1 mix)	N/A	N/A	N/A	N/A
	Concrete designation (BS 8500-2 table 7)	N/A	N/A	N/A	N/A
Binder course (base course)	Dense bituminous macadam (100/150 pen paving grade bitumen) with crushed rock aggregate to BS 4987 (group 2 mix)	60 (0/20 mm size to clause 6.5)	N/A	N/A	N/A
Surface course (wearing course)	Dense bituminous macadam (100/150 pen paving grade bitumen) with crushed rock aggregate to BS 4987 (group 3 mix)	20 (0/6mm size to clause 7.5)	N/A	N/A	<sup>(7)</sup>
	Hot rolled asphalt to BS 594-1	N/A	N/A	N/A	N/A
	Mastic asphalt to BS 1447	N/A	N/A	N/A	N/A
	Concrete designation (BS 8500-2 table 7)	N/A	100 grade PAV 1	N/A	N/A
Bedding course	Sharp sand to BS 7533-3 category II of annex D	N/A	N/A	N/A	N/A
Pavers	Block pavers to BS 6717 of class markings W2, A2 and S3 (weathering, abrasion and slip/skid classes) <sup>(6)</sup>	N/A	N/A	N/A	N/A

**Notes**

- In the first column, European harmonised names are used and UK names are in brackets.
- Where a capping layer is specified, sub-base thickness can be reduced. DMRB Volume 7 Section 2 Part 2 HD 25/95 Foundations Chapter 3 Capping and Sub-base gives guidance on capping and sub-base thickness design based on CBR values with and without a capping layer.
- Thickness is based on the provision of a geotextile membrane underneath the sub-base. Where no geotextile membrane is provided, see Table 3.
- Bond and tack coat should be provided for bituminous mixtures in accordance with BS 4987-2 or BS 594-2.
- Asphalt-based materials can be used as a partial replacement of a full thickness granular sub-base type 1 material.
- Where laid to either a 90 or 45 degree herringbone pattern, the edge perimeter should be laid with one single row of stretcher bond set parallel to the edge restraint. Where block pavers are laid abutting drainage channels, gully grates, etc. the upper surface of the block pavers should be set 3-6mm above the grating. Manufacturer's declared value markings W3 and S4 are acceptable. Where W3 is 1.0 kg/m<sup>2</sup> or less and S4 is 45 or more based on 'C scale unit' (for abrasion, class A2 = maximum result is 23mm, class A1 = no performance determined).
- A 38mm thickness of graded 15/20mm unbound aggregate to BS EN 13242 (gravel), well rolled and compacted, should be used.
- Thicknesses are in mm.
- Reference to clauses are in relation to the relevant British Standards.

**Minimum sub-base thickness**

The thickness of any required capping layer and the sub-base should be determined after investigations and on-site tests have been carried out, with consideration to the:

- CBR value
- frost susceptibility of the sub-grade; where susceptible to frost, a suitable capping layer should be included below the sub-base to a depth to ensure that construction will not be affected by frost heave.

**Table 3:** Minimum sub-base thickness for paved areas

CBR values	Minimum thickness (mm) of sub-base (consolidated in accordance with MCHW Volume 1 clause 801, table 8/1)	
	Without geotextile underneath	With geotextile underneath
Less than 2%	N/A	300
2-3%	325	225
3-5%	250	150
5-7%	150	N/A
7-20%	100	N/A

**House paths and patios**

The following construction will be generally acceptable for house paths and patios:

- The sub-base comprising of a 100mm thickness of clean, well consolidated crushed rock, hardcore (maximum size 75mm), slag or concrete, the surface of which is blinded with 25mm of sand.
- Paving slabs fully bedded in 25mm 1:4 cement:sand mortar or a suitable alternative.

Concrete paths and patios should be not less than 75mm thick and have a tamped or textured finish. The concrete mix should be suitable to give a durable and frost resistant surface, as described in Chapter 3.1 'Concrete and its reinforcement'. Movement joints, not less than 10mm wide, should be provided across the full width of the path at not more than 4m centres. A movement joint is not required at the abutment with a wall unless the opposite edge of the concrete is also restrained.

**Materials <sup>10.2.7</sup>**

**Materials shall be suitable for their intended use. Concrete shall be of a mix design which will achieve sufficient strength for its purpose and be sufficiently durable to remain unaffected by chemical or frost action.**

Sub-base material should be type 1 to clause 803 Table 8/2, MCHW Volume I Series 800.

Hot rolled and mastic asphalts and macadam should comply with relevant standards, including:

<b>BS EN 13108-1</b>	'Bituminous mixtures. Material specifications. Asphalt Concrete'.
<b>BS EN 13108-4</b>	'Bituminous mixtures. Material specifications. Hot Rolled Asphalt'.

Aggregates used in asphalt and macadam mixtures and unbound aggregate (graded 15/20mm gravel) for surfacing should comply with relevant standards, including:

<b>BS EN 13043</b>	'Aggregates for bituminous mixtures and surface treatments for roads, airfields and other trafficked areas'.
<b>PD 6682-2</b>	'Guidance on the use of BS EN 13043'.
<b>BS EN 13242</b>	'Aggregates for unbound and hydraulically bound materials'.
<b>PD 6682-6</b>	'Guidance on the use of BS EN 13242'.

Blocks, slabs, pavers, edgings, etc. should comply with relevant standards, including:

<b>BS EN 771</b>	'Specification for masonry units'.
<b>BS EN 1344</b>	'Clay pavers. Requirements and test methods'.
<b>BS EN 1339</b>	'Concrete paving flags. Requirements and test methods'.
<b>BS 7533</b>	'Pavements constructed with clay natural stone or concrete pavers'.

Topsoil should be of a quality that will not present a hazard to users of the garden area. BS 3882 and the Contaminated Land Exposure Assessment (CLEA) guidelines provide advice on determining the suitability of topsoil.

### Garden areas within 3m of the home <sup>10.2.8</sup>

**In order to provide for adequate access to and utility immediately around the home areas up to 3m from the habitable parts of the home shall not be waterlogged.**

Waterlogging of garden areas within 3m of the habitable parts of the home should be prevented by drainage or other suitable means.

### Garden areas <sup>10.2.9</sup>

**Garden areas within 20m of habitable accommodation shall be adequately prepared, stable and provided with reasonable access.**

The stability of new or existing slopes in garden areas should be determined by an engineer in accordance with Technical Requirement R5. Alternatively, the following maximum gradients should apply:

- Unsupported granular soil should be 5° less than its natural angle of repose.
- Unsupported cohesive soil should not exceed 9° (1:6).

Garden areas should have:

- old foundations, concrete bases and similar obstructions within 300mm of the finished ground surface removed
- appropriate action, such as rotavating, undertaken to restore the drainage characteristics of soil that has been compacted during construction
- ground disturbed during construction re-graded to conform to the general shape of the adjacent ground
- a minimum thickness of 100mm topsoil provided. Topsoil should not contain contaminants which may present a hazard to the occupants. Disturbed topsoil should be reinstated.

Subsoil should not be placed over topsoil. Construction rubbish and debris should be removed from the garden and other areas around the home.

Access is not required to small isolated garden areas, such as narrow strips of land at the top or bottom of retaining walls, but should be provided to other areas where appropriate by steps or other suitable means.

### Timber decking <sup>10.2.10</sup>

*Also see: Chapter 3.3*

**Patios and decking shall be suitable for their purpose.**

Timber decking, including support, should be naturally durable or treated with preservative.

Decking that is more than 600mm above ground level should be:

- in accordance with guidance published by the Timber Decking Association, or
- designed by an engineer in accordance with Technical Requirement R5.

### Landscaping <sup>10.2.11</sup>

**Planting shall be completed in a manner appropriate for the site conditions and layout. Possible future damage to the home caused by planting shall be minimised.**

Where trees or shrubs have been removed, are to be retained or are to be planted by the builder, precautions should be taken to reduce the risk of future damage to homes and services in accordance with Chapter 4.2 'Building near trees'.

NHBC is authorised by the Prudential Regulation Authority and regulated by the Financial Conduct Authority and the Prudential Regulation Authority.

NHBC is registered in England under company number 00320784. NHBC's registered address is NHBC House, Davy Avenue, Knowlhill, Milton Keynes, Bucks MK5 8FP.

NHBC Standards 2017 have been printed on material which is produced from sustainable forests and is fully recyclable and biodegradable, ECF (elemental chlorine free) and is made to ISO 14001 Environmental Certification.



NHBC, NHBC House,  
Davy Avenue, Knowlhill,  
Milton Keynes,  
Bucks MK5 8FP  
Tel: 0344 633 1000  
Fax: 01908 747255  
[www.nhbc.co.uk](http://www.nhbc.co.uk)

