



Question

Which factors should be taken into account when designing and installing spandrel panels over party walls and gable walls with cold roof voids?

1. General considerations

Spandrel panels are generally factory-made, transported to site in one or more sections, and craned into position on to timber framed or masonry support walls. Panel framing is usually formed from vertical studs at 600mm centres, with head and soleplates. Typical timber sizes are:

89 x 38mm or 97 x 47mm with nailed connections or

72 x 47mm where joints are plated, as in trussed rafter plated joints.

Spandrel panels should be designed by the manufacturer in accordance with the building designer's details and requirements and manufactured in accordance with guidance from the Structural Timber Association (www.structuraltimber.co.uk) or Trussed Rafter Association (www.tra.org.uk).

The top of party wall panels should be slightly lower than the level of adjacent trusses, to allow the trusses to deflect on application of the roof tiles, without causing hogging of the tiles over the panel (see Detail 3). Gable panels are installed level with the top of the trusses with flush roof verges; or to underside of gable ladders with boxed verges.

Party wall panels require tying back into the roof structure on BOTH sides, so that they remain in place in the event of the roof on one side burning away. Gable spandrel panels must resist wind loads acting on the gable end walls and any loads from applied cladding, e.g. tile hanging. These loads are transmitted through the panel to the roof structure via lateral restraints. In accordance with masonry codes, wall ties to masonry cladding should be increased in number at the top of a wall. Wall ties should also be increased at potential slip planes, e.g. horizontal cavity tray locations. **Detail 10** below shows where wall tie frequency should be increased.

Any impervious weather protection, e.g. polythene sheeting, should be removed once the roof is watertight, sufficient to allow the panel to breathe, identify stud positions for fixing restraints or wall ties, and checking for any damage during erection. Breathable protective membrane may require removal for inspection if there are signs of trapped moisture or damage to the panel. Where membranes are retained, e.g. on gable panels, the position of the studs should be marked on the membrane for fixing of wall ties.

2. Lateral restraint - Details 1, 2, 4-8

Spandrel panels require lateral restraint at rafter level and along the base of the panel. Tall panels may also require lateral restraint in line with any intermediate longitudinal bracing to the roof trusses. Lateral restraint can be provided by:

- timber members (e.g. the longitudinal bracing secured to the spandrel with timber ledgers/noggings), fixed into at least two studs within the panels,
- metal restraint straps fixed to the panel and to noggings, or timber bracing fixed between or across the trusses.

Multiple fixings into narrow stud widths, e.g. 38mm wide, at the end of restraint straps, should be avoided by fixing the straps into timber ledgers, fixed across and into two studs within the panel - see Detail 1, option 1 below. Alternatively, use the equivalent of the once twisted metal strap which would enable fixing at the head of the tie to be made to the depth of the studs - see Detail 6, option 2.

3. Fire stopping - Detail 3

Fire stopping is required between the top of the party wall spandrel panel and the roof covering, and between the spandrel and the masonry supporting wall. This is typically achieved with flexible rock fibre mineral quilt. The firestopping should extend into any boxed eaves in the form of fire-resisting board or wired rock fibre quilt, screwed or nailed in place (see diagram in NHBC

Spandrel panels to cold roofs

(June 2022) (Second issue - supersedes January 2018))

Standards clause 7.2.16).

4. Fire protection

The building designer/architect should agree fire protection requirements with the NHBC building control surveyor for the project (or local authority building control in Scotland and Northern Ireland), particularly for panels clad with weatherboarding or tile hanging, where lack of fire resistance to external face can be affected by fire spread from below. Requirements should be clearly illustrated on the working drawings.

Generally party wall spandrel panels should provide 60 minutes fire protection, which can be achieved with two layers of 12.5mm plasterboard on both sides of the framing. Plasterboard joints in each layer and between layers should be made over a stud or nogging and staggered. With twin leaf spandrel panels the same fire protection is applied to one side of each leaf, usually the side facing the roof void.

Alternatively, single layer board drylining may be used if supported by suitable test reports to show compliance with the fire and sound requirements.

Fire protection to gable end spandrel panels is dependent on the dwelling type, e.g. house or flat, its height, and distance from relevant boundaries. Based on Approved Document B1 (England) and 100mm thick masonry tied to the gable spandrel panel, the following fire protection generally applies:

- i Three storey houses and two storey flats.

External spread of fire (Requirement B4) may apply if the building is close to a boundary and the area of the gable wall is larger than the 'allowable unprotected area' for the plot. Where a 30 minute period of fire resistance is needed, an unlined spandrel panel with 100mm masonry wall is considered to meet this requirement.

- ii Houses and flats with height exceeding (i) above.

External spread of fire (Requirement B4) may apply if the building is close to a boundary and the area of the gable wall is larger than the 'unprotected area'. A 60 minute period of fire resistance is needed. An unlined spandrel panel and 100mm masonry wall is NOT considered sufficient to meet this period. Consideration should be given to fire protection of the spandrel panel, such as a lining to the internal face of the panel.

Panel-to-panel butt joints should maintain the required fire protection. This can be achieved by covering the joint with strips of plasterboard to the same thickness as used on the main panel - see detail below. Other panel to panel jointing methods may be accepted if supported by an appropriate fire test report. Jointing methods which rely on the use of intumescent sealants are difficult to inspect for correct installation, so should generally be avoided.

5. Acoustics

The spandrel panel should meet the sound insulation requirements set out in the National Building Regulations. One way of achieving this is to follow the guidance in Robust Details; the guidance in this document follows that approach. Designs which do not adopt Robust Details will require sound testing on completion.

6. Types of spandrel panels and worked examples

The types of spandrel panel covered by this guidance are as follows:

Type One - Twin leaf panels supported on a timber framed party wall

Type Two - Single leaf panel supported on a timber framed party wall

Type Three - Single leaf panel supported on a masonry party wall

Type Four - Single leaf panel supported on a timber framed gable wall

Type Five - Single leaf panel supported on the inner leaf of a masonry cavity gable wall

Type Six - Single leaf panel supported on the outer leaf of a masonry cavity gable wall

7. Typical details

The following drawings show commonly accepted practice and are included to help illustrate the points described in this guidance. The actual design and restraint of the panels may vary depending on the site conditions. The design, manufacture and provision of lifting points for the erection of the spandrel panels should be undertaken by the panel manufacturer. The restraint of the panels, once erected, should be designed by the building designer/architect to suit the structural and fire requirements for each project. Erection procedures and temporary restraint requirements are outside the scope of this guidance.

TYPE ONE
Twin leaf spandrel panel supported on a timber framed party wall (generic twin wall system)

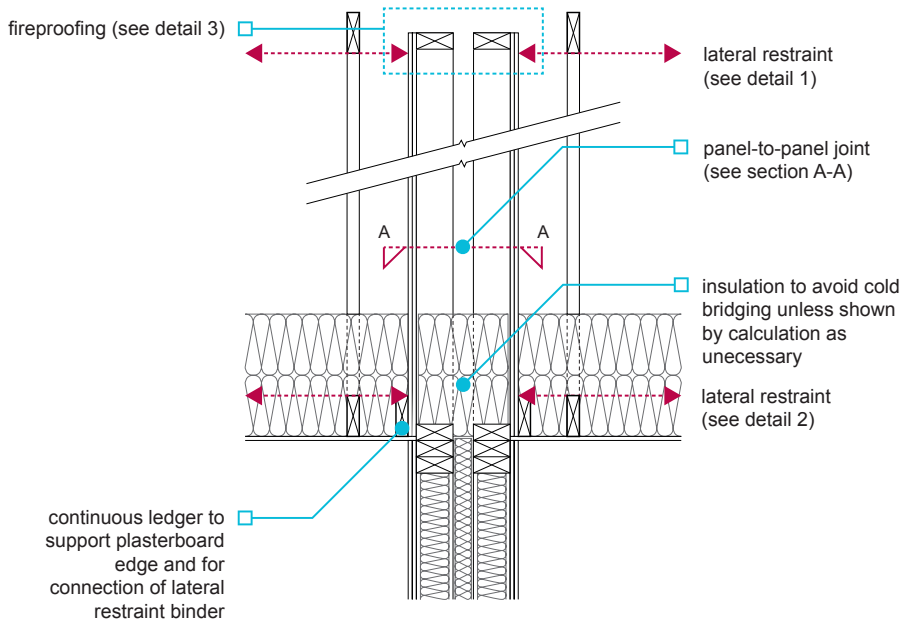

TYPE TWO
Single leaf spandrel panel supported on a timber framed party wall

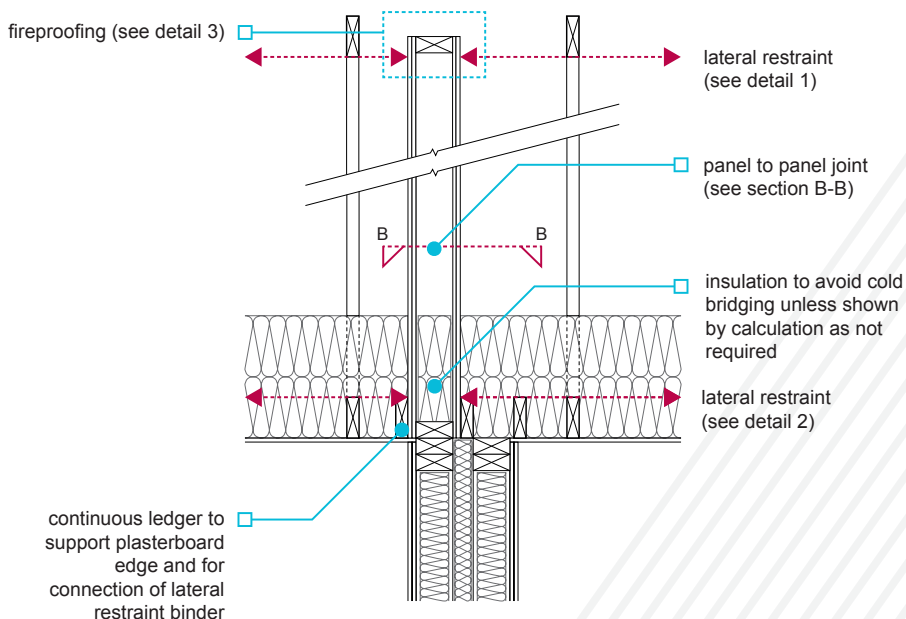

TYPE THREE

Single leaf spandrel panel supported on a masonry party wall

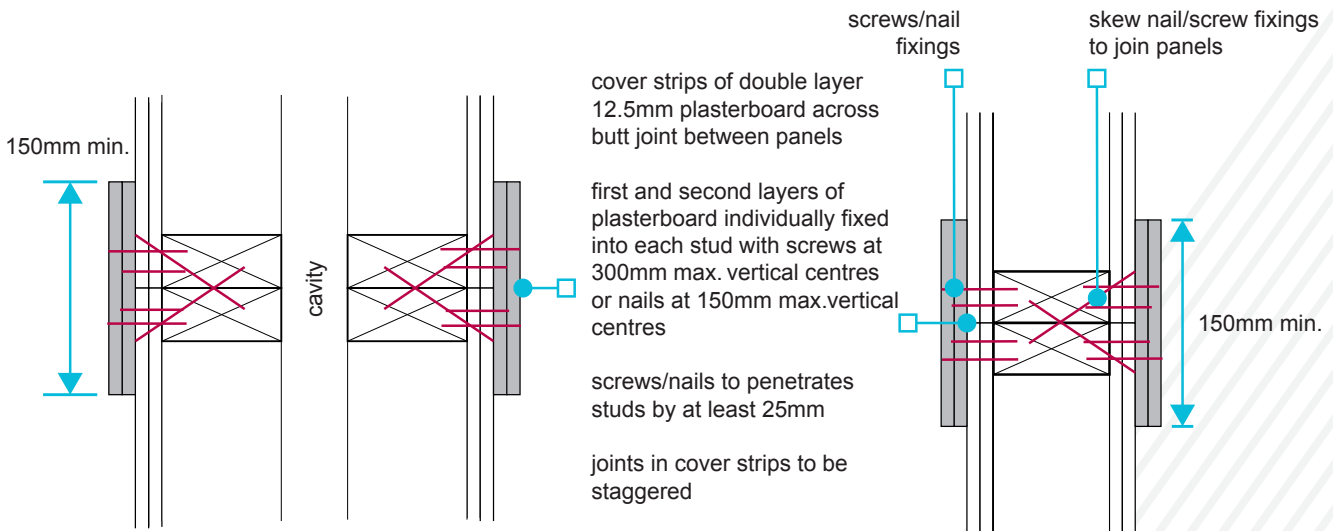
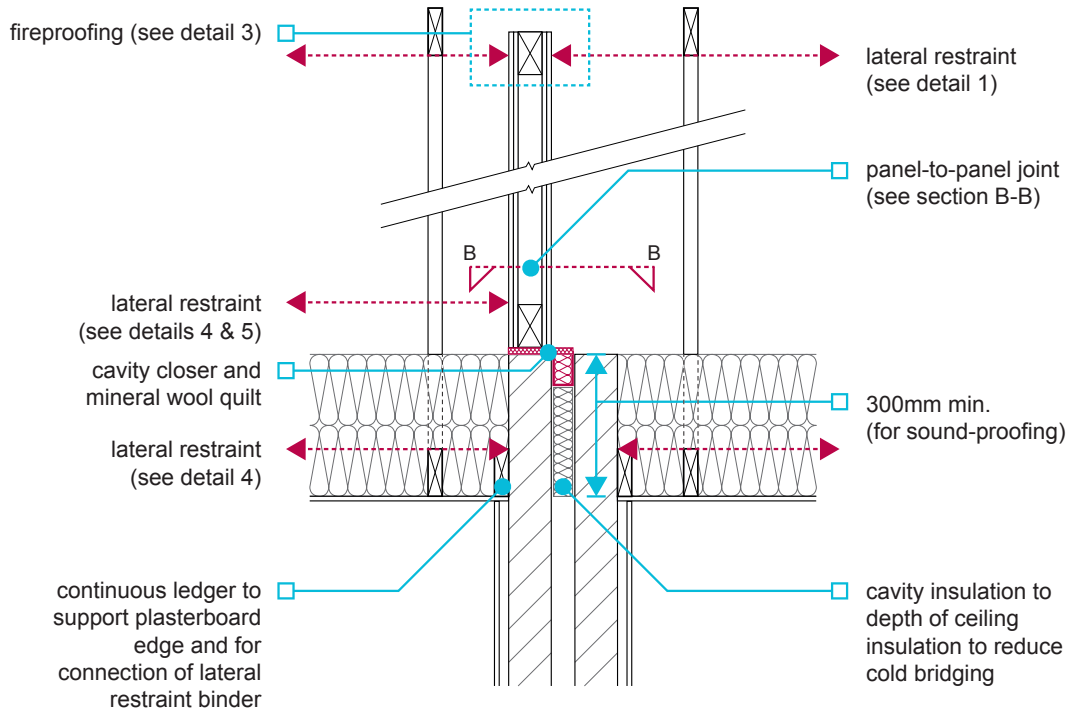

Section-view A-A of joint in spandrel panel

Section-view B-B of joint in spandrel panel

Spandrel panels to cold roofs

(June 2022) (Second issue - supersedes January 2018)

TYPE FOUR

Single leaf spandrel panel supported on a timber framed gable wall

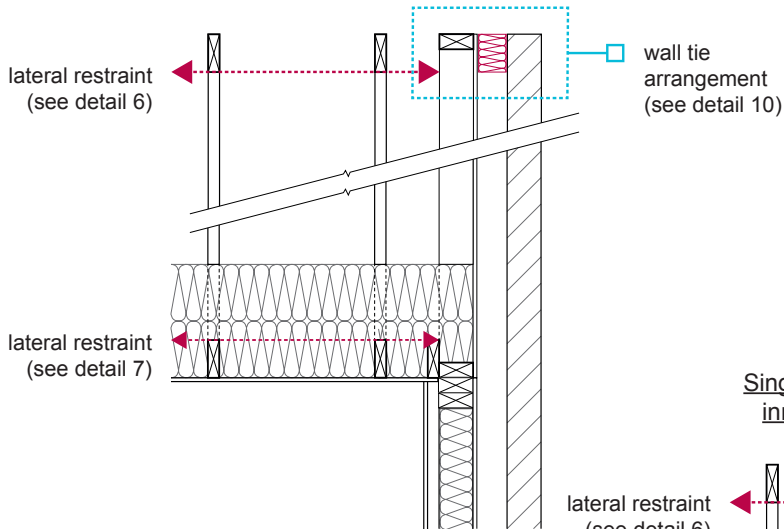

TYPE FIVE

Single leaf spandrel panel supported on the inner leaf of a masonry cavity gable wall

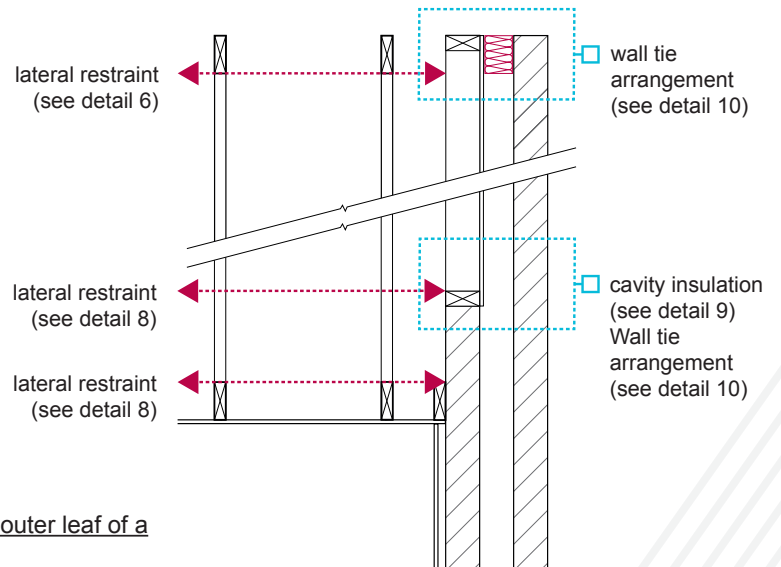

TYPE SIX

Single leaf spandrel panel supported on the outer leaf of a masonry cavity gable wall

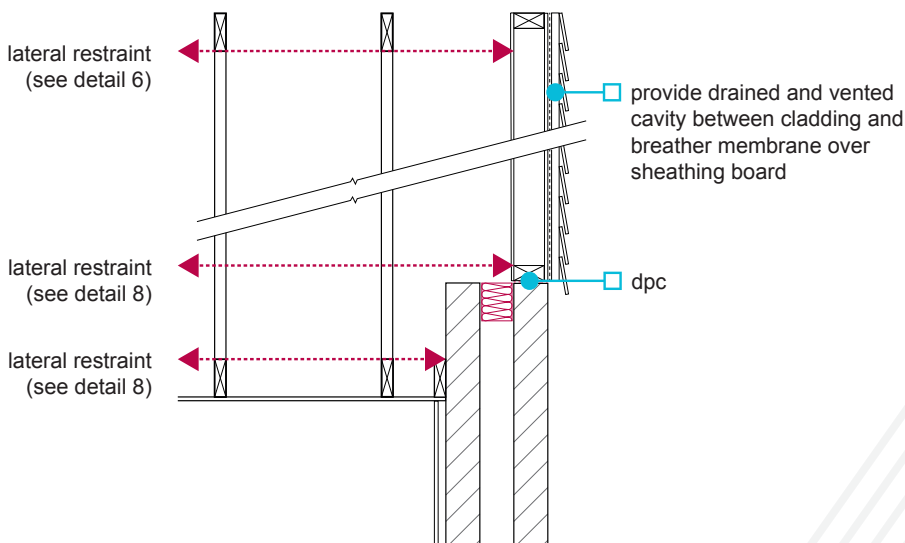

Spandrel panels to cold roofs

(June 2022) (Second issue - supersedes January 2018)

Detail 1

Options 1 and 2 – Lateral restraint to the top of spandrel panel(s) over timber framed or masonry party wall

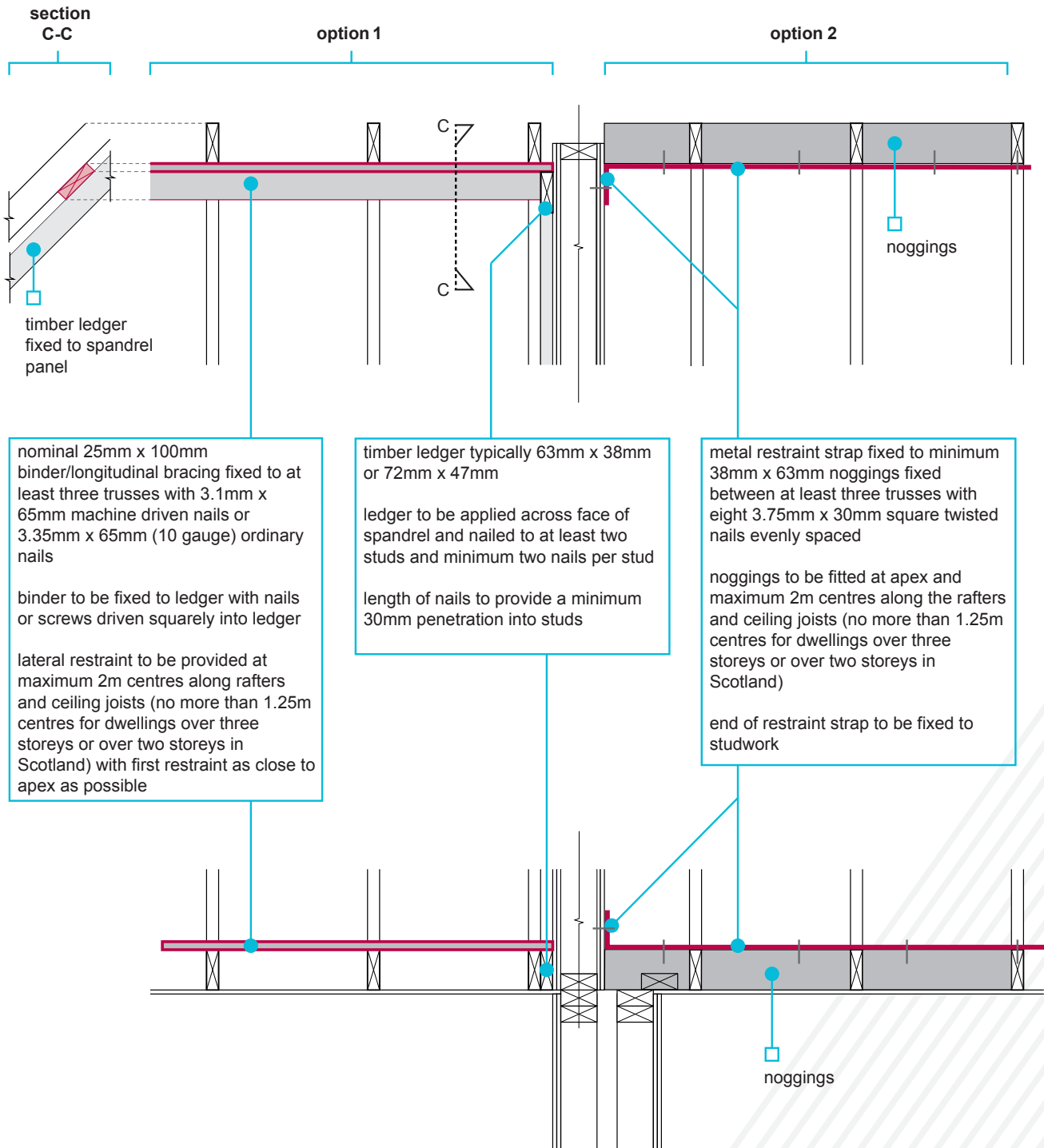

Detail 2 – Options 1 and 2 – Lateral restraint to the bottom of spandrel panel(s) over timber framed party wall

Spandrel panels to cold roofs

(June 2022) (Second issue - supersedes January 2018)

Detail 3 – Fire stopping between top of party wall spandrel panel and roof covering

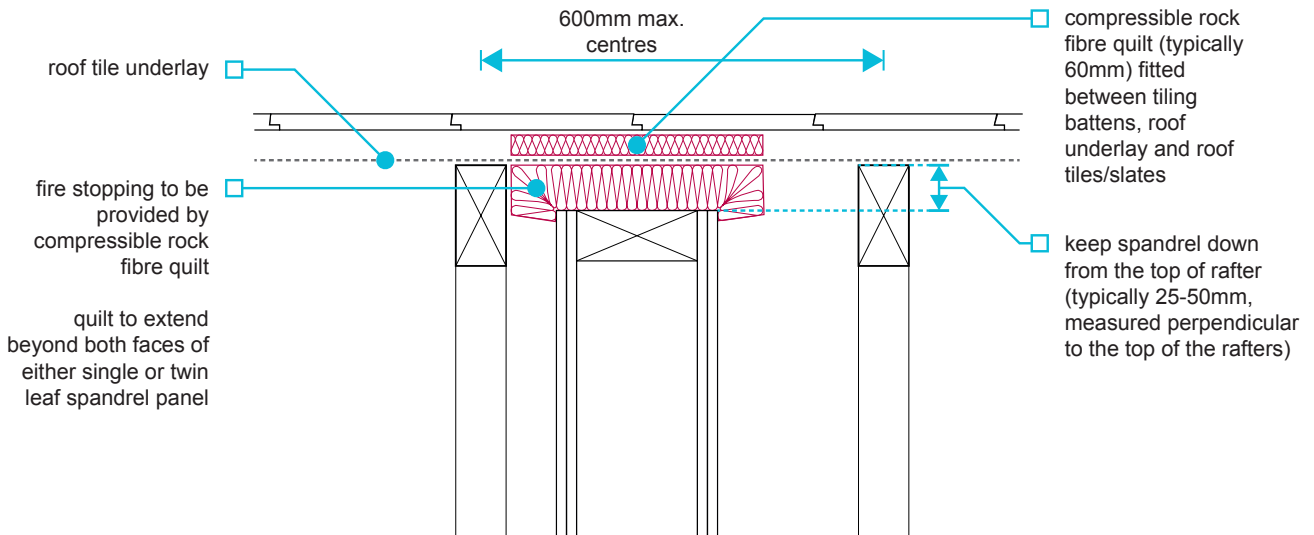

Details 4 and 5 – Lateral restraint to the bottom of single leaf spandrel panel on a masonry party wall

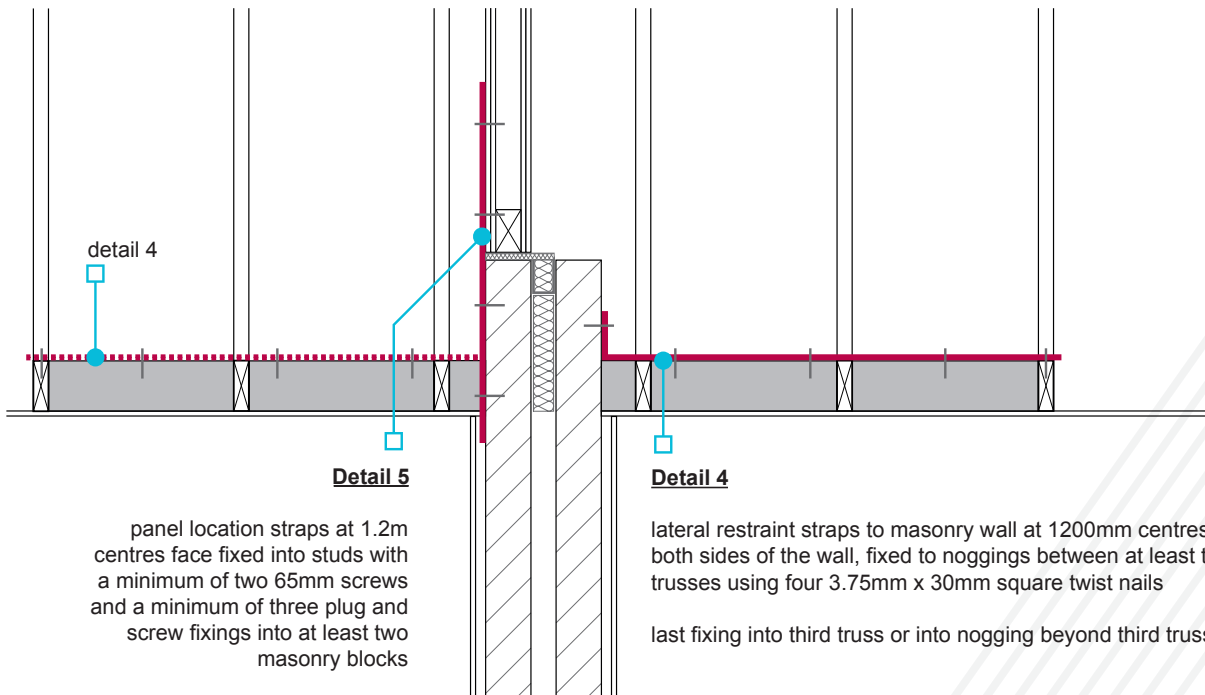

ALTERNATIVELY, in place of noggings use 25mm x 100mm binder fixed to at least three trusses with 3.1mm x 65mm machine driven nails or 3.35mm x 65mm (10 gauge) ordinary nails

straps fixed to binder with eight 25mm x 4mm steel screws

straps fixed to wall with three plastic wall plugs and 4mm diameter (N°8) screws

Spandrel panels to cold roofs

(June 2022) (Second issue - supersedes January 2018)

Detail 6 – Lateral restraint to top of gable end spandrel panel

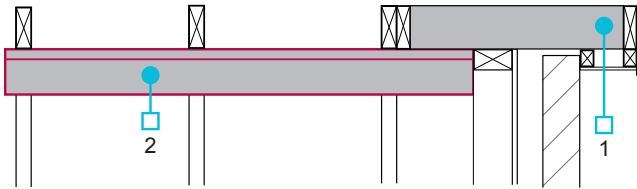

Option 1

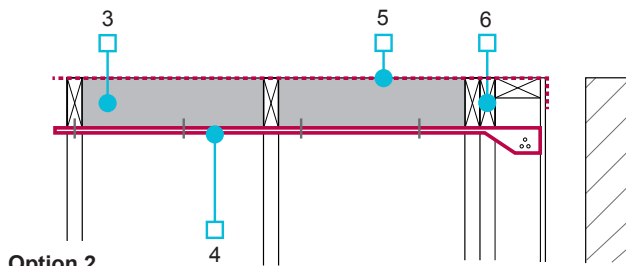

Option 2

Detail 7 – Lateral restraint to bottom of gable end spandrel panel on to timber framed wall

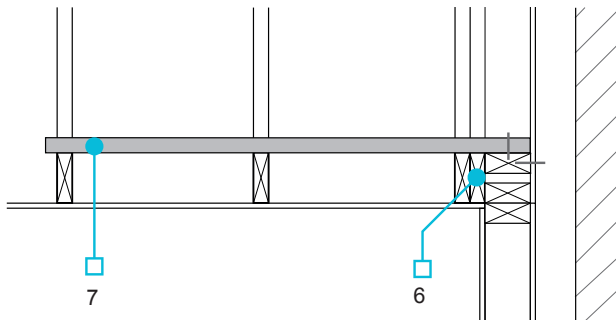

Detail 8 – Lateral restraint to bottom of gable end spandrel panel onto masonry wall

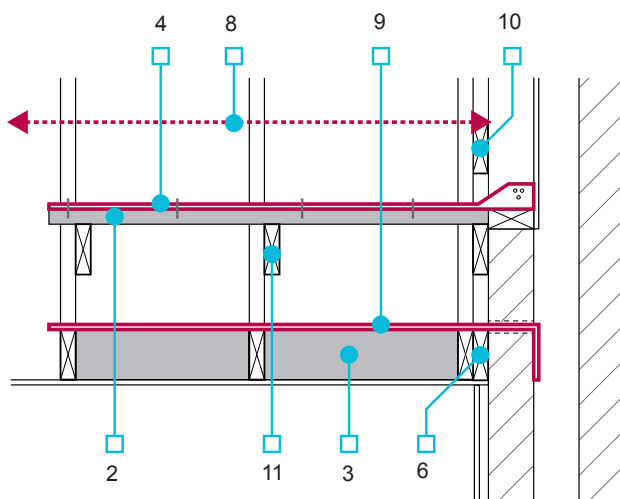

KEY

- 1 ladder truss securely fixed to first roof truss with soffit board overlapping and tight to outer wall (allow for settlement gap between masonry and gable ladder for timber framed buildings)
- 2 nominal 25mm x 100mm longitudinal binders or additional timber bracing fixed across at least three trusses and butted tight against panel (for centres see note 4)
- 3 noggings minimum 38mm wide fixed between at least three trusses (for centres see note 4)
- 4 metal restraint straps fixed to binders with eight 25mm x 4mm steel screws, or to noggings with four steel screws or four 75mm x 4mm (8 SWG) round nails with last fixing into third truss or nogging beyond

end of each restraint strap to be fixed to a panel stud with fixings capable of resisting 8 kN force based on restraint straps at maximum centres

restraint straps/binders located at, or near to apex and down the rafters and along ceiling joists at maximum 2m centres (no more than 1.25m centres for buildings over three storeys or over two storeys in Scotland)

- 5 alternative location for metal restraint strap
 - 6 timber blocking piece between truss and spandrel panel
 - 7 nominal 25mm x 100mm longitudinal binders, or additional timber bracing, fixed across at least three trusses and into nogging fixed between panel studs (for centres see note 4), nogging to be securely fixed to framing including fixings through sheathing board, fixings to resist 8kN force based on restraint straps at maximum centres
 - 8 with larger trusses intermediate longitudinal bracing may be provided across struts, such bracing should extend to the spandrel panel and be fixed to a timber ledger minimum 72mm x 47mm or 63mm x 38mm nailed or screwed to at least two studs with two nails/screws per stud, length of fixings to provide a minimum 30mm penetration into the studs
 - 9 restraint strap built into masonry wall either through core drilled hole, e.g. 38mm diameter, or slot cut through inner leaf with slot mortared up after installation of strap
 - 10 timber ledger minimum 72mm x 47mm or 63mm x 38mm
 - 11 additional timber cross member fixed to trusses to support raised binder
- note:** holding down straps between panel and masonry have been omitted for clarity. such strapping should be designed to suit the specific site conditions.

Spandrel panels to cold roofs

(June 2022) (Second issue - supersedes January 2018)

Detail 9 – Gable spandrel supported on inner leaf masonry wall extended above ceiling level with cavity insulation

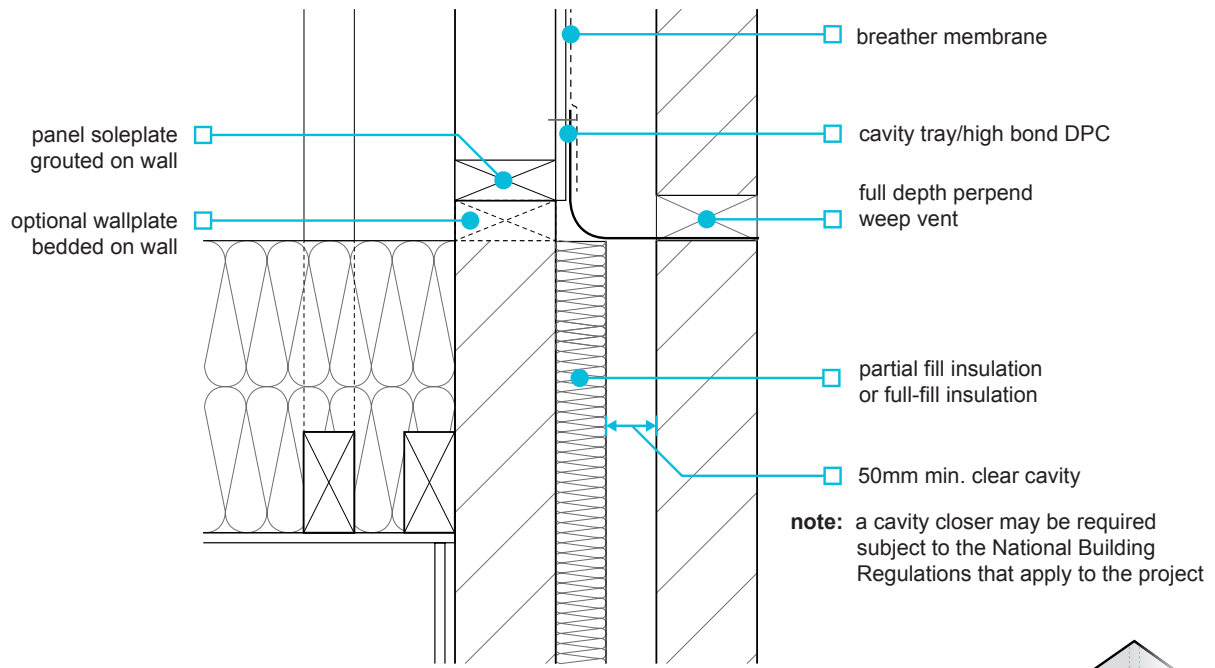

Detail 10 – Positioning of wall ties at the top of spandrel panels at gable ends

