

Technical Guidance

Retaining walls across private gardens

Question

Is permanent access and guarding always required to retaining walls across private gardens?

Considerations

- NHBC Standards clauses 9.2 - D3(b) & S7(a) require steps and guarding where structures retain land more than 600mm high to which people have access.
- NHBC Standards clause 9.2 - D6 states access is not required to small isolated garden areas such as narrow strips of land at the top or bottom of retaining walls.
- Areas of low maintenance planting above or below a retaining wall may only require limited access for maintenance.

Answer

Where any area of land above a retaining wall is planted solely with low maintenance plants which require only infrequent access for maintenance and the retaining structure cannot be readily climbed by young children (under 5 years), permanent access and guarding is not required (See diagram 1).

Temporary access e.g. a ladder, can be provided by the gardener who should be aware of the potential risk of falling from unguarded drops and be responsible for their own safety.

Where land below a retaining wall is similarly planted permanent access is not required but guarding is required in accordance with NHBC Standards clause 9.2 - S7(a) (See diagram 2).

Technical Guidance

Retaining walls across private gardens

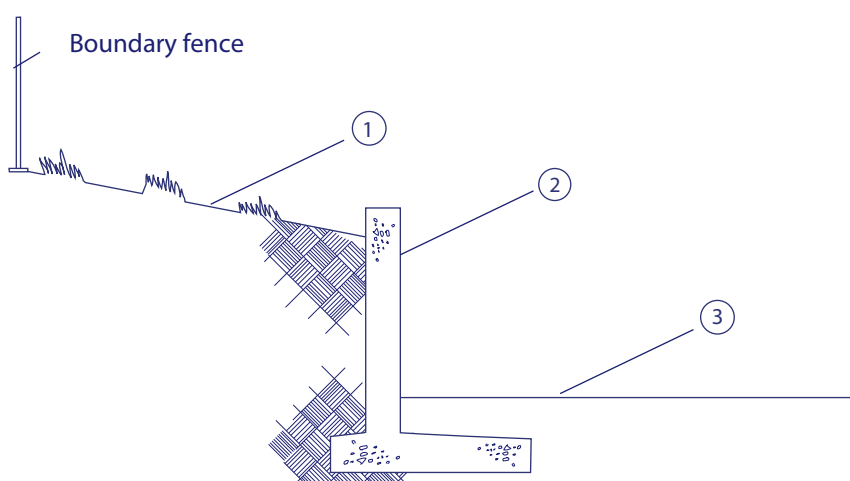

Diagram 1 - No guarding or permanent access required

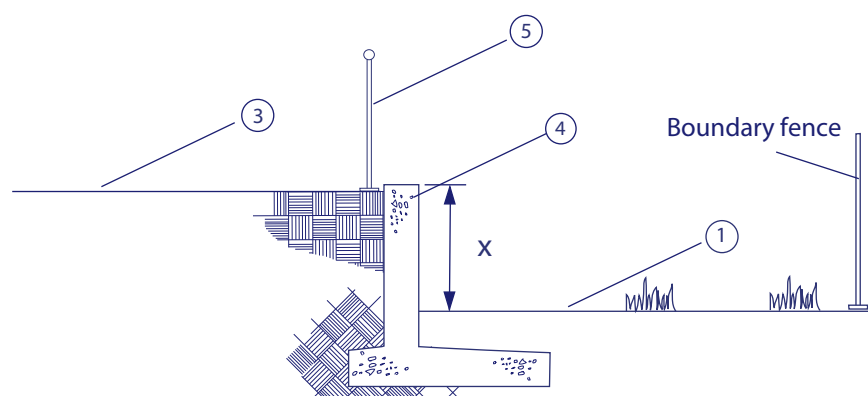

Diagram 2 - No permanent access required
- Guarding required where 'x' is greater than 600mm

- 1 Low maintenance planting to whole area
- 2 Retaining structure not readily climbed by children under 5 years e.g. fairface masonry at least 900mm high
- 3 Main garden area for family use
- 4 Retaining structure
- 5 Guarding where 'x' is greater than 600mm. Guarding to be 1100mm high, not readily climbed by children with no gaps able to pass 100mm sphere.