

TECHNICAL GUIDANCE

DISCHARGE PIPES FROM UNVENTED HOT WATER STORAGE SYSTEMS

8.1/26 - January 2016 (First issue as Technical Guidance)

QUESTION

How should a discharge pipe from unvented hot water storage system (UVHWSS) be terminated to provide a safe and noticeable discharge?

CONSIDERATIONS

- If the safety device on a UVHWSS operates a substantial quantity of hot water and steam is discharged.
- National Building Regulations describe ways in which a discharge pipe, from an UVHWSS should be terminated to avoid any discharge causing harm to people.
- A discharge should be visible to alert of a potential problem with the system and the need for further investigations and maintenance/repair.

ANSWER

The following locations for the termination of the discharge pipe from an UVHWSS are acceptable. Note: The guidance does not apply to discharge pipes from combi boilers or sealed central heating systems. These systems could discharge at higher temperatures and so the discharge should be terminated externally in accordance with Technical Guidance xxx

Low Level

- into a gully below the grating but above the water level (see diagram 1).

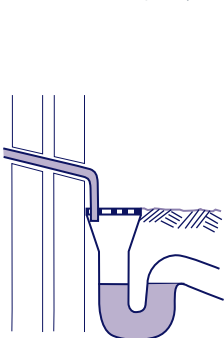

Diagram 1

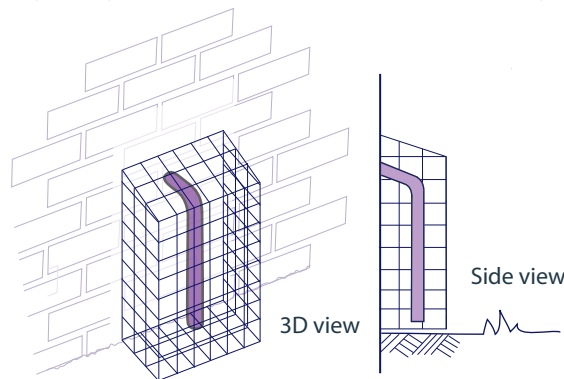

Diagram 2

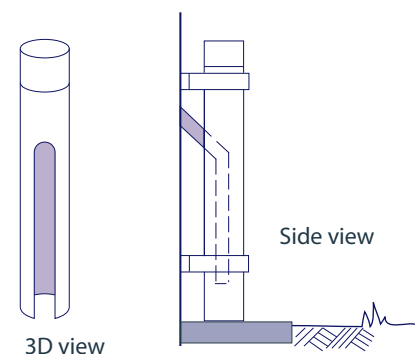

Diagram 3

- Onto the ground (drive, path or garden area). The pipe should discharge downwards and be no more than 100mm above ground level. The discharge should be protected against children being able to touch the discharge with fingers or hand before it has hit the ground. This is normally achieved by installing a cage over the discharge pipe (see diagram 2). Alternatively a proprietary plastic waste pipe with a slotted back and capped top can be used (see diagram 3). The bottom of the plastic pipe should finish in contact with a solid surface so that the discharge takes place through the slot at the rear.

High Level

- High level discharge is only acceptable:
 - onto a flat or pitched roof capable of withstanding water at high temperature and at least 3m away from plastic guttering, or
 - into a metal hopper and downpipe which terminates at low level (see diagrams 1 or 2).
- Where discharge pipes extend down the outside of buildings, it is not necessary to provide protection to the exposed pipe (the discharge should still be protected as shown in diagrams 1,2 or 3).

Connection into SVP

- Connection into an SVP is acceptable for all locations as an alternative to low and high level discharge arrangements described above.
- Connection into an SVP is only permitted with the use of a Hepworth HepVo waterless trap installed as shown (see diagram 4).
- The trap should be installed vertically.
- The minimum discharge pipe sizes and lengths must be met.
- The discharge pipework should not connect with any other waste pipework/traps.

Pipework material

The discharge pipe and fittings should normally be metal. Alternatively polypropylene pipes and fittings, as described below, are an acceptable alternative material.

Polypropylene pipes and fittings should be marked to either BS 5254 'Specification for Polypropylene waste pipe and fittings' or BS EN 1451-1 'Plastic piping systems for soil and waste discharge (low and high temperature) within the building structure'. The pipe should be marked with the following at max 1M intervals:

- a) Manufacturer's identification.
- b) The number of the British Standards 'BS 5254' or 'BS EN 1451'.
- c) The material code (PP)
- d) The nominal size.

As polypropylene cannot be solvent welded, push-fit joints should be used.

Polypropylene pipework should be adequately supported in accordance with the manufacturer's recommendations (normally clipped at 300mm centres).

Polypropylene pipework can be affected by sunlight so is unsuitable for use externally.

Diagram 4
Unvented hot water storage system

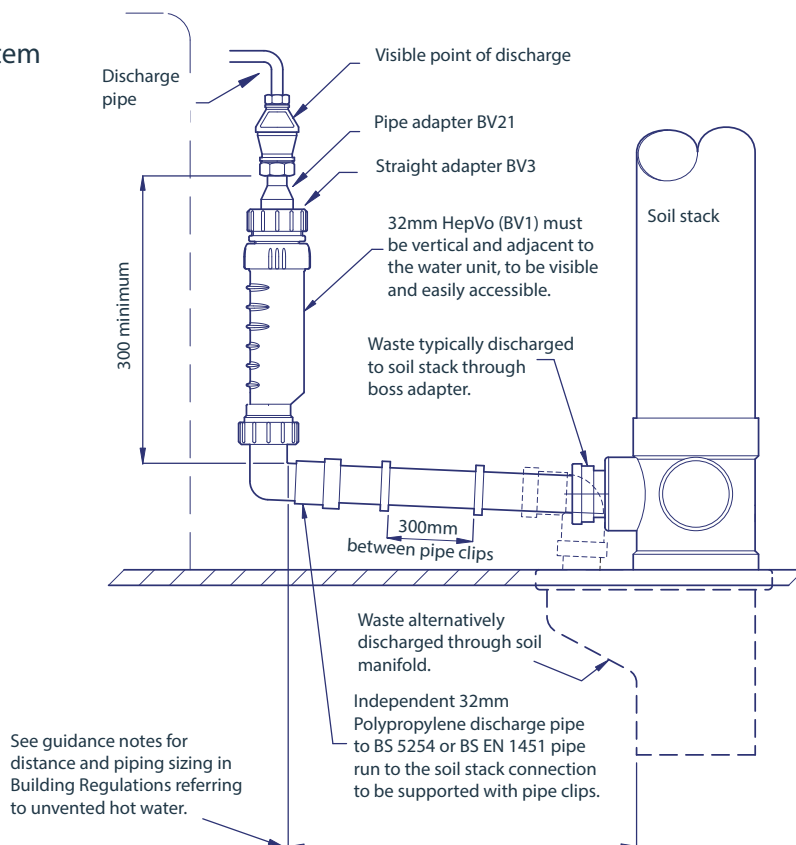

Note: Where the discharge pipe up to the tundish is 15mm the discharge from the HepVo trap to the SVP can be in 22mm metal pipework providing the discharge from the tundish does not exceed 8.2m in length.