

Technical Guidance

Support of joist hangers



Question

Is it acceptable to support floor joists on joist hangers on a masonry wall where there is no masonry above the built-in flange of the hanger, such as directly below a door opening or on an intermediate wall which terminates at the point of support?

Considerations

- NHBC Standards clauses 6.4 – S3 and S4 refer to support of floor joists in joist hangers built into masonry walls.
- It is essential that the built-in flange of the joist hanger has a sufficient height of masonry above to prevent the flange from straightening and pulling away from the wall when floor loads are applied.
- Manufacturers' guidance should be followed on how to build in and support their joist hangers. Typical guidance is that 675mm of masonry should be constructed above the joist hanger and allowed to set before any other loads are applied to the floor.

Answer

Joist hangers should be fully retained by an adequate height of masonry above the built-in flange in accordance with the manufacturer's guidance.

Floor joists supported on intermediate masonry walls with no masonry above should themselves be fully supported on the wall and not rely on hangers.

Joist ends which occur directly under a wide opening, ie. where three or more hangers are not fully retained by masonry above, should be built into the wall or, if hangers are to be used, the joist ends should be supported by hangers on a trimmer spanning the width of the opening and fixed to trimming joists either side (see diagram). Trimmers, trimming joists and their hangers should be suitably designed to cater for the load conditions.

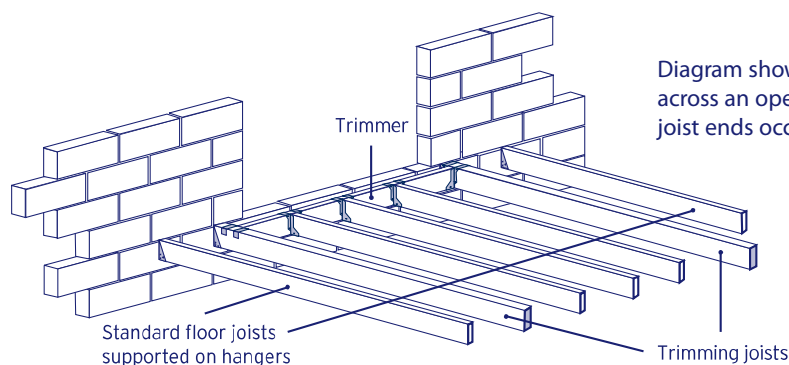

Diagram showing the use of a trimmer across an opening where three or more joist ends occur at the opening.