

Lateral restraint at rafter and ceiling levels – at wall steps and staggers

(May 2024) (Second issue – supersedes March 2020)

The Technical Guidance Notes are produced by NHBC as guidance solely for our builder customers as to how to interpret the technical requirements in relation to the warranty cover provided by NHBC under its Buildmark, Buildmark Choice, Buildmark Link, Buildmark Solo, Buildmark Connect or any similar product from time to time. It has not been created or intended for distribution or use outside of that purpose. The information contained in this Technical Guidance Note does not constitute advice and is not to be relied upon by any third party. Nothing in this Technical Guidance Note is intended to, nor should it be taken to, create any legal or contractual relationship. Any third party who chooses to rely upon the information contained in the Technical Guidance Notes shall do so entirely at their own risk and NHBC accepts no duty of care or liability, however caused, in connection with its use or reliance by any third party.

Question

What minimum restraints are required at rafter and ceiling levels to meet NHBC and regulatory requirements, particularly at stepped and/or staggered junctions?

General consideration

Lateral restraint is needed to restrict movement of the separating or gable wall. This Technical Guidance clarifies the requirements of relevant Building Regulations and British Standards. It is assumed the leaves of a cavity wall are adequately tied together and this guidance applies only to residential buildings of consequence classes of up to 2a as defined in Approved Document A.

Answer

RESTRAINT TO SEPARATING WALLS – AT RAFTER LEVEL

Rafter level or within 300mm vertical step on one side of the wall

Timber Frame

Restraint can be provided by longitudinal braces tightly abutting and secured via a timber ledger or block to both sides of the separating wall. Braces should be provided at nodal points only for dwellings up to 3 storeys and further assessment and additional bracing may be required for dwellings over 3 storeys. Braces should be in line or nearly in line on each side of the wall and fixed across at least three rafters. Longitudinal braces that are present to provide stability to a trussed rafter roof can also be used for restraint of the wall but additional braces will usually be needed to achieve the required spacing.

Masonry

Restraint straps should be provided to one side of the wall only, unless the design shows that strapping to both sides is required. Straps should be no more than 2m apart for dwellings up to 3 storeys (2 storeys in Scotland) and no more than 1.25m apart for dwellings over 3 storeys and fixed across at least three rafters as shown in NHBC Standards Chapter 7.2.8 – Restraint.

Rafters greater than 300mm vertical step one side of the wall

Restraint straps should be provided. They can be on one side of the wall only (at the higher rafter level), unless the design shows that strapping on both sides is required. Straps should be no more than 2m apart for dwellings up to 3 storeys (2 storeys in Scotland) and no more than 1.25m apart for dwellings over 3 storeys and fixed across at least three rafters as shown in NHBC Standards Chapter 7.2.8 – Restraint.

Lateral restraint at rafter and ceiling levels – at wall steps and staggers

(May 2024) (Second issue – supersedes March 2020)

Horizontal staggers in separating walls – rafter level

Where there is a stagger (on plan) between two dwellings greater than 2m for dwellings up to 3 storeys (2 storeys in Scotland) and 1.25m for dwellings over 3 storeys, the rafter level restraint should be provided to the exposed staggered sections of the separating wall as for a gable wall (see 'Restraint to gable walls' below).

RESTRAINT TO SEPARATING WALLS – AT CEILING LEVEL

Lateral restraint is only required at ceiling level where H is greater than $16t$, where:

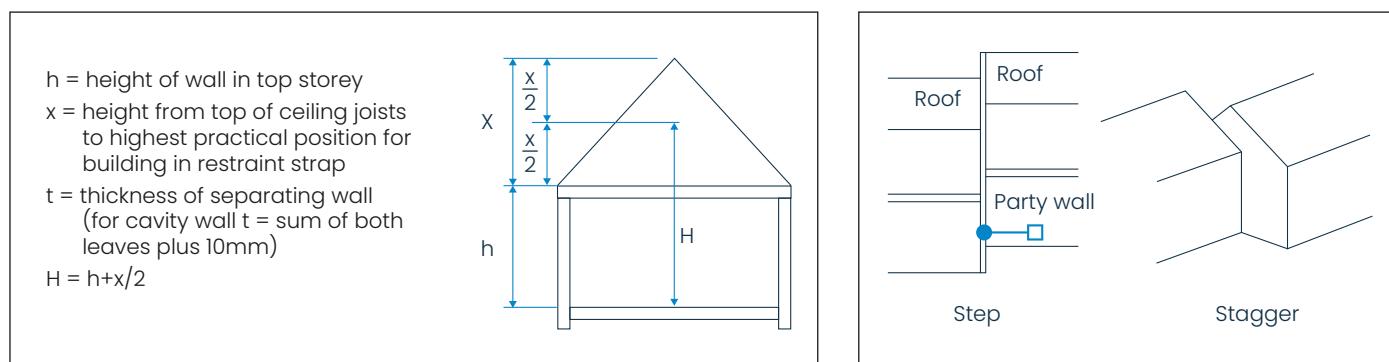

Ceiling joists level or within 300mm vertical step on one side of the wall

Timber Frame

Restraint can be provided by longitudinal braces tightly abutting and secured via a timber ledger to both sides of the separating wall.

Braces should be provided at nodal points only for dwellings up to 3 storeys and further assessment and additional bracing may be required for dwellings over 3 storeys. Braces should be in line or nearly in line on each side of the wall and fixed to at least three rafters. Longitudinal braces that are present to provide stability to a trussed rafter roof can also be used for restraint of the wall but additional braces will usually be needed to achieve the required spacing.

Masonry

Restraint straps should be provided to one side of the wall only, unless the design shows that strapping to both sides is required. Straps should be no more than 2m apart for dwellings up to 3 storeys (2 storeys in Scotland) and no more than 1.25m apart for dwellings over 3 storeys. Straps should be fixed across at least three ceiling joists as shown in NHBC Standards Chapter 7.2 clause 7.2.8 – Restraint.

Ceiling joists greater than 300mm vertical step one side of the wall

Restraint straps should be provided. They can be on one side of the wall only (at the higher ceiling level), unless the design shows that strapping to both sides is required. Straps should be no more than 2m apart for dwellings up to 3 storeys (2 storeys in Scotland) and no more than 1.25m apart for dwellings over 3 storeys. Straps should be fixed across at least three ceiling joists as shown in NHBC Standards Chapter 7.2 clause 7.2.8 – Restraint.

Horizontal staggers in separating walls – rafter level

Where there is a stagger (on plan) between two dwellings greater than 2m for dwellings up to 3 storeys (2 storeys in Scotland) and 1.25m for dwellings over 3 storeys, the staggered section of the separating wall should be restrained as a gable wall (see 'Restraint to gable walls' below).

Lateral restraint at rafter and ceiling levels – at wall steps and staggers

(May 2024) (Second issue – supersedes March 2020)

Restraint to gable walls

Restraint straps should be provided at rafter level at all times and at ceiling level where H is greater than 16t as described in 'Restraint to separating wall – at ceiling level' above. Restraint straps should be provided at no more than 2m apart for dwellings up to 3 storeys and no more than 1.25m apart for dwellings over 3 storeys (2 storeys in Scotland) and fixed across at least three rafters/ceiling joists as shown in NHBC Standards Chapter 7.2 clause 7.2.8 – Restraint.



NHBC, NHBC House, Davy Avenue, Knowlhill, Milton Keynes, Bucks MK5 8FP
Tel: 0344 633 1000 Web: [nhbc.co.uk](https://www.nhbc.co.uk)

National House-Building Council (NHBC) is authorised by the Prudential Regulation Authority and regulated by the Financial Conduct Authority and the Prudential Regulation Authority for carrying on insurance business and insurance distribution activities.

NHBC is registered in England and Wales under company number 00320784. NHBC's registered address is NHBC House, Davy Avenue, Knowlhill, Milton Keynes, Buckinghamshire, MK5 8FP. Note that only certain parts of our products and services are within the scope of UK financial services regulations. For more information on our products and services, please see our website [nhbc.co.uk](https://www.nhbc.co.uk) or your NHBC product documentation.

HB2851 05/24 W010bu