

Retaining walls across private gardens

(June 2022) (Second issue - supersedes December 2008)



Question

Is permanent access and guarding always required to retaining walls across private gardens?

Considerations

- NHBC Standards clauses 10.2.5 require steps and guarding where structures retain land more than 600mm high to which people have access.
- NHBC Standards clause 10.2.9 states access is not required to small isolated garden areas such as narrow strips of land at the top or bottom of retaining walls.
- Areas of low maintenance planting above or below a retaining wall may only require limited access for maintenance.

Answer

Where any area of land above a retaining wall is planted solely with low maintenance plants which require only infrequent access for maintenance and the retaining structure cannot be readily climbed by young children (under 5 years), permanent access and guarding is not required (See diagram 1).

Temporary access e.g. a ladder, can be provided by the gardener who should be aware of the potential risk of falling from unguarded drops and be responsible for their own safety.

Where land below a retaining wall is similarly planted permanent access is not required but guarding is required in accordance with NHBC Standards clause 10.2.5 (See diagram 2).

Retaining walls across private gardens

(June 2022) (Second issue - supersedes December 2008)

TECHNICAL
GUIDANCE

10.2/08

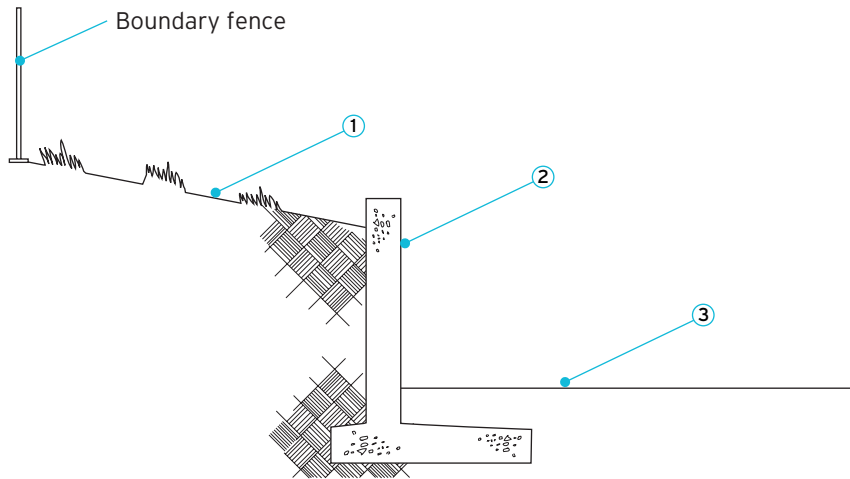

Diagram 1 - No guarding or permanent access required

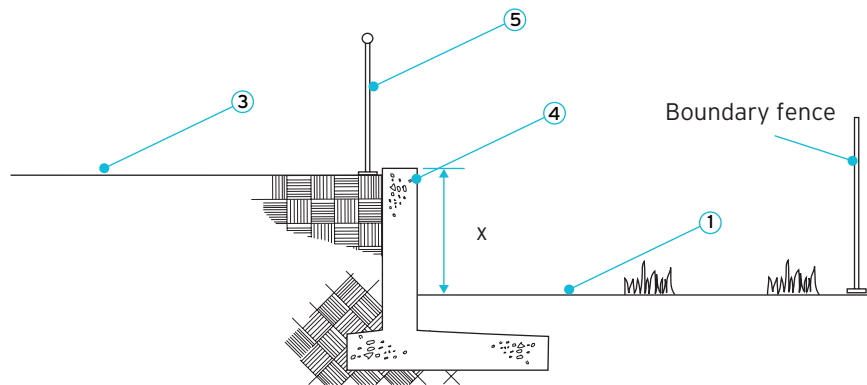

Diagram 2 - No permanent access required
- Guarding required where 'x' is greater than 600mm

- 1 Low maintenance planting to whole area
- 2 Retaining structure not readily climbed by children under 5 years e.g. fairface masonry at least 900mm high
- 3 Main garden area for family use
- 4 Retaining structure
- 5 Guarding where 'x' is greater than 600mm. Guarding to be 1100mm high, not readily climbed by children with no gaps able to pass 100mm sphere.